



**MOHAMED SATHAK A.J. COLLEGE OF ENGINEERING**

(Approved by AICTE, New Delhi and Affiliated to Anna University, Chennai)



**DEPARTMENT OF MECHANICAL ENGINEERING**  
**(ACADEMIC YEAR: 2022-2023)**

[www.EnggTree.com](http://www.EnggTree.com)

**ME3392 – ENGINEERING MATERIALS AND METALLURGY**

**(Regulation 2021)**  
**Semester - III**

**COURSE OBJECTIVES:**

- 1 To learn the constructing the phase diagram and using of iron-iron carbide phase diagram for microstructure formation.
- 2 To learn selecting and applying various heat treatment processes and its microstructure formation.
- 3 To illustrate the different types of ferrous and non-ferrous alloys and their uses in engineering field.
- 4 To illustrate the different polymer, ceramics and composites and their uses in engineering field.
- 5 To learn the various testing procedures and failure mechanism in engineering field.

**UNIT I CONSTITUTION OF ALLOYS AND PHASE DIAGRAMS 9**

Constitution of alloys – Solid solutions, substitutional and interstitial – phase diagrams, Isomorphous, eutectic, eutectoid, peritectic, and peritectoid reactions, Iron – Iron carbide equilibrium diagram. Classification of steel and cast-Iron microstructure, properties and application.

**UNIT II HEAT TREATMENT 9**

Definition – Full annealing, stress relief, recrystallisation and spheroidising –normalizing, hardening and tempering of steel. Isothermal transformation diagrams – cooling curves superimposed on I.T. diagram – continuous cooling Transformation (CCT) diagram – Austempering, Martempering – Hardenability, Jominy end quench test -case hardening, carburizing, Nitriding, cyaniding, carbonitriding – Flame and Induction hardening – Vacuum and Plasma hardening – Thermo-mechanical treatments- elementary ideas on sintering.

**UNIT III FERROUS AND NON-FERROUS METALS 9**

Effect of alloying additions on steel (Mn, Si, Cr, Mo, Ni, V, Ti & W) – stainless and tool steels – HSLA - Maraging steels – Grey, white, malleable, spheroidal – alloy cast irons, Copper and its alloys – Brass, Bronze and Cupronickel – Aluminium and its alloys; Al-Cu – precipitation strengthening treatment – Titanium alloys, Mg-alloys, Ni-based super alloys – shape memory alloys- Properties and Applications- overview of materials standards

**UNIT IV NON-METALLIC MATERIALS 9**

Polymers – types of polymers, commodity and engineering polymers – Properties and applications of PE, PP, PS, PVC, PMMA, PET, PC, PA, ABS, PAI, PPO, PPS, PEEK, PTFE, Thermoset polymers – Urea and Phenol formaldehydes –Nylon, Engineering Ceramics – Properties and applications of Al<sub>2</sub>O<sub>3</sub>, SiC, Si<sub>3</sub>N<sub>4</sub>, PSZ and SIALON – intermetallics- Composites- Matrix and reinforcement Materials- applications of Composites - Nano composites.

**UNIT V MECHANICAL PROPERTIES AND DEFORMATION MECHANISMS 9**

Mechanisms of plastic deformation, slip and twinning – Types of fracture – fracture mechanics- Griffith's theory- Testing of materials under tension, compression and shear loads – Hardness tests (Brinell, Vickers and Rockwell), Micro and nano-hardness tests, Impact test Izod and Charpy, fatigue and creep failure mechanisms.

**TOTAL: 45 PERIODS****OUTCOMES:**

At the end of the course the students would be able to

1. Explain alloys and phase diagram, Iron-Iron carbon diagram and steel classification.
2. Explain isothermal transformation, continuous cooling diagrams and different heat treatment processes.
3. Clarify the effect of alloying elements on ferrous and non-ferrous metals.
4. Summarize the properties and applications of non-metallic materials.
5. Explain the testing of mechanical properties.

**TEXT BOOKS:**

1. Kenneth G. Budinski and Michael K. Budinski, "Engineering Materials", Prentice Hall of India Private Limited, 9<sup>th</sup> edition, 2018.
2. Sydney H. Avner, "Introduction to Physical Metallurgy", McGraw Hill Book Company, 1994

**REFERENCES:**

1. A. Alavudeen, N. Venkateshwaran, and J. T. Winowlin Jappes, A Textbook of Engineering Materials and Metallurgy, Laxmi Publications, 2006.
2. Amandeep Singh Wadhwa, and Harvinder Singh Dhaliwal, A Textbook of Engineering Material and Metallurgy, University Sciences Press, 2008.
3. G.S. Upadhyay and Anish Upadhyay, "Materials Science and Engineering", Viva Books Pvt. Ltd, New Delhi, 2020.
4. Raghavan.V, "Materials Science and Engineering", Prentice Hall of India Pvt. Ltd. 6th edition, 2019.
5. Williams D Callister, "Material Science and Engineering" Wiley India Pvt Ltd, 2nd edition Re print 2019.

**UNITI ALLOYS AND PHASE DIAGRAMS**

Constitution of alloys  
Solid solutions, substitutional and interstitial  
Phase diagrams,  
Isomorphous,  
Eutectic, eutectoid, peritectic, and peritectoid reactions,  
Iron – carbon equilibrium diagram.  
Classification of steel and cast Iron microstructure, properties and application.

**1. CONSTITUTION OF ALLOYS\***

Most of the metallic elements readily alloy with aluminum, but only a few are important major alloying ingredients in commercial aluminum-based alloys. Nevertheless, an appreciable number of other elements serve as supplementary alloying additions for improving alloy properties and characteristics.

**TYPES OF SYSTEMS**

A few generalizations, relating to the periodic system, can be made concerning the types of binary systems the various elements form with aluminum. Beryllium, silicon, zinc, gallium, germanium, tin, and mercury form simple eutectic-type systems with aluminum. Except for beryllium, these elements are in periodic groups IIb, IIIa, and IVa. Cadmium, indium, thallium, and lead of these groups; bismuth of group Va; and sodium and potassium (also probably rubidium and cesium) of group Ia are only partly miscible in liquid aluminum within an appreciable temperature range above its melting point. Therefore, they form simple, monotectic-type systems with aluminum. In binary combinations, aluminum forms no known intermetallic phases or compounds with these elements. Available data indicate that the remaining metallic elements, including those of the lanthanide and actinide series, are miscible in the liquid state and form more complex binary systems, in which one or more intermetallic phases occur. In these systems, a eutectic reaction generally occurs involving the liquid, the aluminum terminal solid solution, and the aluminum-rich intermetallic phase. However, solid solution is formed near the extreme aluminum end of the system by peritectic reaction between the liquid and the aluminum-rich intermetallic phase with titanium, vanadium, chromium, zirconium, columbium, molybdenum, hafnium, and probably tantalum and tungsten (the elements of groups IVa, Va, and VIa in the fourth, fifth, and sixth periods). Of the many binary intermetallic phases formed by the reaction of aluminum with the various metallic elements, a few solidify without the occurrence of compositional changes (congruent transformation). However, the majority form a liquid solution of the solid phase composition on cooling, by reaction between a previously existing solid phase and the remaining depleted liquid solution (peritectic reaction). Despite similarities, distinct relationships between the number or types of aluminum intermetallic phases and the elements within a periodic group are difficult to observe.

**Liquid Solubility.**

Except for the partly miscible elements previously mentioned, all other metallic elements are completely miscible with aluminum in the liquid state. The solubility limits for a number of elements at temperatures above the melting point of aluminum are listed in Table 1. Of the semimetallic and nonmetallic elements, silicon is completely miscible with aluminum in the liquid state. Boron has a low solubility of about 0.02% at a eutectic temperature slightly below the melting point of aluminum. Its solubility increases with increasing temperature, but appears

to be less than 1.5% at 1500 °C (2730 OF). Carbon has slight solubility in liquid aluminum; its solubility limits have not been completely established, but are indicated to be appreciably less than for boron.

Phosphorous and arsenic are nearly insoluble in aluminum. In hypothetical diagrams, sulfur has been indicated as having appreciable solubility in liquid aluminum. Early investigations indicated complete miscibility of selenium and tellurium with liquid aluminum. Although compounds are readily formed with aluminum, retention of more than trace amounts of these elements in the metal when melting and alloying are done under the usual atmospheric conditions is not possible. Three factors contribute to the difficulty of maintaining the composition: (1) high volatility of these elements at temperatures of liquid aluminum, (2) oxidation at the metal surface, and (3) formation of less dense compounds that separate to surface dross. Except for hydrogen, common elemental gases and elements of the halogen group exhibit no detectable liquid solubility, but readily form compounds with aluminum. The solubility of hydrogen in both liquid and solid aluminum is discussed in Chapter 1 of this Volume. Figure 1 (Ref 1) shows the solubility of hydrogen in aluminum from 500 to 800°C (930 to 1470 OF).

#### Solid Solubility.

No element is known to have complete miscibility with aluminum in the solid state. Of all elements, zinc has the greatest solid solubility in aluminum (a maximum of 66.4 at. %). In addition to zinc, silver, magnesium, and lithium have solid solubilities greater than 10 at.% (in order of decreasing maximum solubility). Gallium, germanium, copper, and silicon (in decreasing order) have maximum solubilities of less than 10 but greater than 1 at. %. All other elements are less soluble. Solid solution limits for some elements in aluminum are recorded in Table 2. The solid solution limits given for lithium are from recent investigations by Costa and Marshall (Ref 2) and by Levine and Rapperport. While the results of these investigators are in agreement, they differ considerably at temperatures below 500°C (930 OF) from the results recently obtained by other investigators. Jones and Das (Ref 4) reported solubility limits of 4.2, 1.7, and 0.4% lithium, respectively, at the eutectic temperatures of 400 °C (750 OF) and 200 °C (390 OF). With one known exception,\* maximum solid solubility in aluminum alloys occurs at the eutectic, peritectic, or monotectic temperature. With decreasing temperature, the solubility limits decrease. This decrease from appreciable concentrations at elevated temperatures to relatively low concentrations at low temperatures is one fundamental characteristic that provides the basis for substantially increasing the hardness and strength of aluminum alloys by solution heat treatment and subsequent precipitation aging operations.

1.3 PHASE DIAGRAMS provide a graphical means of presenting the results of experimental studies of complex natural processes, such that at a given temperature and pressure for a specific system at equilibrium the phase or phases present can be determined.

*SYSTEM* - Any portion of the universe which is of interest and can be studied experimentally.

*PHASE*- any particular portion of a system, which is physically homogeneous, has a specific composition, and can be mechanically removed or separated from any other phase in the system. e.g. A system containing a mixture of ol and pl in equilibrium contains two phases - ol and pl.

In petrology we generally deal with primary phases - any crystalline phase which can coexist with liquid, i.e. it formed/crystallized directly from the liquid.

*EQUILIBRIUM* - The condition of minimum energy for the system such that the state of a reaction will not change with time provided that pressure and temperature are kept constant.

*COMPONENT* - the smallest number of independent variable chemical constituents necessary to define any phase in the system. Components may be oxides, elements or minerals, dependant on the system being examined. For example, experiments carried out in the H<sub>2</sub>O system, show that the *phases* which appear over a wide temperature and pressure range are ice, liquid water and water vapour. The composition of each phase is H<sub>2</sub>O and only one chemical parameter or *component* is required to describe the composition of each phase.

### THE PHASE RULE

For a system at equilibrium the phase rule relates:

- P = number of phases that can coexist, to
- C = number of components making up the phases, and
- F = degrees of freedom.
- Where these three variables are related in the equation

$$P + F = C + 2$$

The degrees of freedom represent the environmental conditions which can be independently varied without changing the number of phases in the system. Conditions include:

Temperature,

- Pressure,
- Chemical Composition,
- pH,
- Eh,
- Oxygen Fugacity.

www.EnggTree.com

Therefore the maximum number of phase which can stably coexist in a one component system is three, and they do so only if there are no degrees of freedom.

Definitions:

**PHASE:** a homogenous, physically distinct portion of the system, e.g., liquid, solid, gas.

**COMPONENT:** pure chemical substance, e.g., element or compound. H<sub>2</sub>O is one component, a compound.

**DEGREE OF FREEDOM:** state variables which can be changed continuously and independently, e.g., pressure, temperature, composition.

**CONSTITUENT:** the association of phases in a recognizably distinct fashion with a distinct melting point, e.g., eutectic.

**COMPOSITION:** fraction of one component to all the components. May be in terms of weight or atoms.

Phase Rule of Willard Gibbs

Let P = number of phases

Let F = number of degrees of freedom Let C = number of components

These are related by the phase rule:  $P + F = C + 2$

## Phase Diagram

The phase diagram is a map showing which phases of a material are in equilibrium at any given temperature, composition, and pressure. It is drawn from experimental data and may be used to determine at equilibrium:

The number of phases present (P) the composition of each phase (X)  
the amount of each phase present as a function of temperature and composition.

Of particular interest to integrated circuit fabrication is the binary partial solid solubility phase diagram. The solidus curve can be used for determining the solid solubility limit ( $N_{sl}$ ) used in diffusion problems.

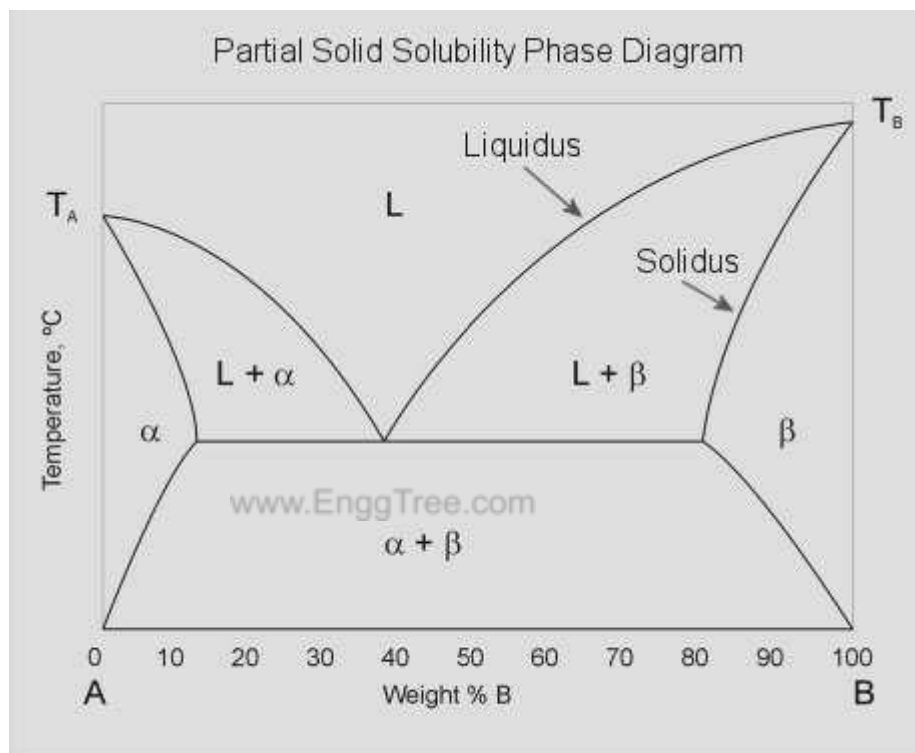

Figure -1.1

where:

L = liquid A+B fully intermixed

$\alpha$  = impure solid A (A doped with B)  $\beta$  = impure solid B (B doped with A)  $L + \alpha$  = liquid A+B, with solid  $\alpha$

$L + \beta$  = liquid A+B, with solid  $\beta$

solidus = maximum composition where a solid solution ( $\alpha$  or  $\beta$ ) can exist

Note in the figure that for a binary phase diagram there can exist three degrees of freedom (*two components* ( $C=2$ ), *at least one phase must be present* ( $P=1$ ), *so*  $F=3$ ). In order to present the diagram elegantly, the system is shown for pressure = 1 atmosphere (isobaric), leaving temperature for the vertical axis and composition for the horizontal axis.

The composition, X, of a system can be defined two ways.

$$X_{\text{weight}} = \frac{W_B}{W_A + W_B}$$

W<sub>a</sub> = weight Modern

where n = moles

Given the initial composition ( $x_i$ ) and weight ( $w_A + w_B$ ) of a binary system, the composition and weight of each phase can be calculated. For the liquid (L)  $\alpha$ , and  $\beta$  cases, the composition and weight are the same as the initial composition and weight (only one phase is present). The two phase regions (L+ $\alpha$  and L+ $\beta$ ) require the use of the *Lever Rule* to calculate the weight and composition of each phase (solid and liquid).

Lever Rule

$$W_S (x_S - x_i) = W_L (x_i - x_L)$$

where

$w_S$  = weight of the solid ( $\alpha$  or  $\beta$ )

$w_L$  = weight of the liquid (liquid A+B)  $x_i$  = original composition

$x_S$  = composition of the solid ( $\alpha$  or  $\beta$ )

$x_L$  = composition of the liquid (liquid A+B)

$x_S$  and  $x_L$  are found from the phase diagram

-  $x_S$  corresponds to the intersection of the *solidus* curve with the system temperature and is read from the horizontal axis

-  $x_L$  corresponds to the intersection of the *liquidus* curve with the system temperature and is read from the horizontal axis

**1.2 Types of solid solution:**

There are two types of solid solutions formed

- Substitutional solid solution
  - (a) Random(Disordered)      (b) Ordered
- Interstitial solid solution

**i) Substitutional solid solution :-**

Substitutional solid solutions are formed when some of the solvent atoms (Base metal atoms) are replaced by the solute atoms (alloying elements atoms) in a crystal lattice.

Substitutional solid solution occurs when the solute and solvent solution (atoms) are equal or approximately equal in diameter

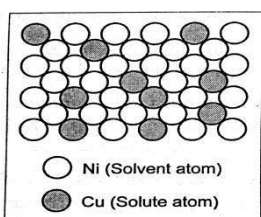

Fig. 1.3. Substitutional solid solution (with nickel atoms substituting for copper atoms on FCC atom sites)

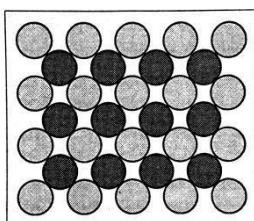

Fig. 1.5. Ordered substitutional solid solution

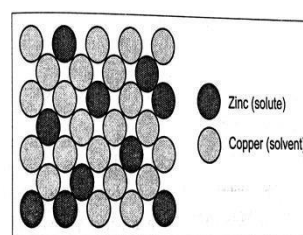

Fig. 1.4. Random substitutional solid solution (zinc in copper, i.e., brass). The crystal pattern is not altered.

Ex: Cu-Ni where Cu has radius of 1.28 Å and Ni has radius 1.2 Å Both and Nickel have FCC crystal structure. The crystal structure of the solvent is unchanged, But the lattice may be distorted by the presence of solute atoms, particularly if there is significant difference in atoms radii's of the solute and solvent atoms.

- a) **Random or Disordered substitution solid solution:** In Random solid solution, the solute atoms do not occupy any specific position but are randomly distributed in the lattice structure of solvent. The concentrations of the solute atoms vary throughout the lattice structure of the solvent.
- b) **Ordered Substitutional solution:** When the atoms of the solute material occupy similar lattice point with the crystal structure of the solvent material, the solid solution is called ordered solution. During slow cooling, diffusion tends to produce uniform distribution of solute and solvent atoms. The solute atoms move in definite orderly manner and occupy orderly position in the lattice. Cu-Zn , Au-Cu , Cu<sub>2</sub> MnAl are some examples of ordered structures.

### **Interstitial solid solution**

Interstitial solutions are formed when the solute atoms are very small in comparison with solvent atoms. The solute atoms occupy the holes(or) interstices between the solvent atoms. Here the solution (or) solute atoms are much smaller than the parent atoms and have occupied randomly in the interstitial voids between parent atoms.

The most important interstitial solid solution present in ferrous metals is ferrite which consists of pure iron containing upto 0.008% carbon at room temperature. In several, hydrogen, carbon , nitrogen and boron having small atomic diameters form interstitial solid solutions with the base metal atoms. Atomic size is not only a parameter which determines whether or not an interstitial solid solution, will form but also small solute atoms like Fe, Ni, Mn, Mo , Cr, W etc dissolve more readily in transition metals

A binary alloy may be

- a. a single solid solution
- b. two separated, essentially pure components.
- c. two separated solid solutions.
- d. a chemical compound, together with a solid solution.

The way to tell is to cut the material, polish it to a mirror finish, etch it with a weak acid (components etch at a different rate) and observe the surface under a microscope.

### **Phase Equilibria**

Equilibrium is the state of minimum energy. It is achieved given sufficient time. But the time to achieve equilibrium may be so long (the *kinetics* is so slow) that a state that is not at an energy minimum may have a long life and appear to be stable. This is called a *metastable state*. A less strict, operational, definition of equilibrium is that of a system that does not change with time during observation.

### ***Equilibrium Phase Diagrams***



Give the relationship of composition of a solution as a function of temperatures and the quantities of phases in equilibrium. These diagrams do not indicate the dynamics when one phase transforms into another. Sometimes diagrams are given with pressure as one of the variables. In the phase diagrams we will discuss, pressure is assumed to be constant at one atmosphere.

### Binary Isomorphous Systems

This very simple case is one complete liquid and solid solubility, an *isomorphous* system. The example is the Cu-Ni alloy of Fig. 9.2a. The complete solubility occurs because both Cu and Ni have the same crystal structure (FCC), near the same radii, electronegativity and valence. The *liquidus line* separates the liquid phase from solid or solid + liquid phases. That is, the solution is liquid above the liquidus line. The *solidus line* is that below which the solution is completely solid (does not contain a liquid phase.)

### Interpretation of phase diagrams

*Concentrations: Tie-line method*

- a. locate composition and temperature in diagram
- b. In two phase region draw tie line or isotherm
- c. note intersection with phase boundaries. Read compositions.

*Fractions: lever rule*

- a. construct tie line (isotherm)
- b. obtain ratios of line segments lengths.

*Note:* the fractions are inversely proportional to the length to the boundary for the particular phase. If the point in the diagram is close to the phase line, the fraction of that phase is large.

### Development of microstructure in isomorphous alloys

#### a) Equilibrium cooling

Solidification in the solid + liquid phase occurs gradually upon cooling from the liquidus line. The composition of the solid and the liquid change gradually during cooling (as can be determined by the tie-line method.) Nuclei of the solid phase form and they grow to consume all the liquid at the solidus line.

#### b) Non-equilibrium cooling

Solidification in the solid + liquid phase also occurs gradually. The composition of the liquid phase evolves by diffusion, following the equilibrium values that can be derived from the tie-line method. However, diffusion in the solid state is very slow. Hence, the new layers that solidify on top of the grains have the equilibrium composition at that temperature but once they are solid their composition does not change. This lead to the formation of layered (cored) grains (Fig. 9.14) and to the invalidity of the tie-line method to determine the composition of the solid phase (it still works for the liquid phase, where diffusion is fast

**Eutectic, eutectoid, peritectic, and peritectoid reactions**

1. **Eutectic reaction**
2. **Eutectoid reaction**
3. **Peritectic reaction**
4. **Peritectoid reaction (4) Eutectic reaction:**

A eutectic reaction is a three-phase reaction, by which, on cooling, a liquid transforms into two solid phases at the same time. It is a phase reaction, but a special one. For example: liquid alloy becomes a solid mixture of alpha and beta at a specific temperature (rather than over a temperature range). The eutectic solid is commonly lamellar (stripy) in form.

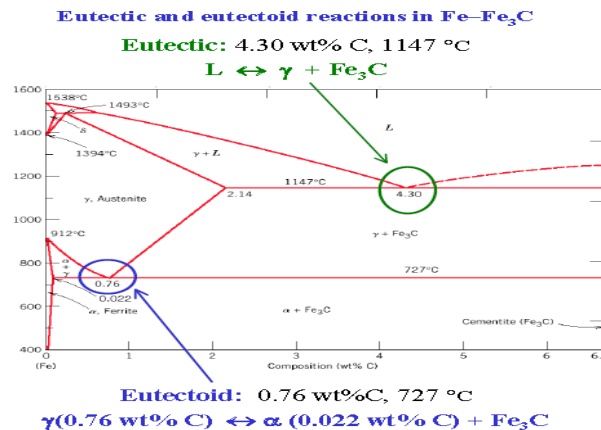
**Eutectoid reaction:**

The eutectoid reaction describes the phase transformation of one solid into two different solids. In the Fe-C system, there is a eutectoid point at approximately 0.8wt% C, 723°C. The phase just above the eutectoid temperature for plain carbon steels is known as austenite or gamma. We now consider what happens as this phase is cooled through the eutectoid temperature (723°C).

**Peritectic Reaction:**

A peritectic reaction is a reaction where a solid phase and liquid phase will together form a second solid phase at a particular temperature and composition - e.g.

Liquid + alpha --> beta

These reactions are rather sluggish as the product phase will form at the boundary between the two reacting phases thus separating them, and slowing down any further reaction. Peritectics are not as common as eutectics and eutectoids, but do occur in some alloy systems. There's one in the Fe-C system.

Diagram showing the Peritectic reaction, where a liquid and solid together form a new solid phase.

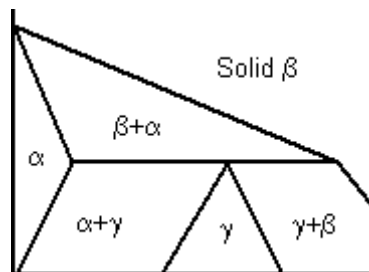
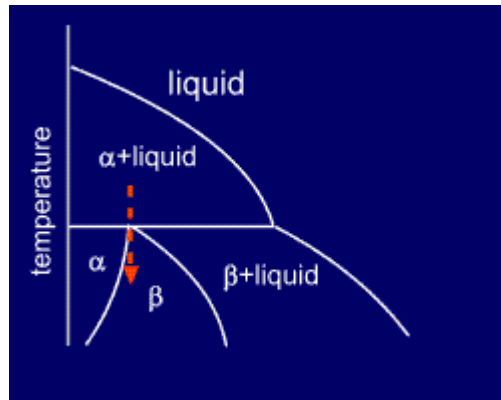

www.EnggTree.com

### **Peritectoid reaction:**

A three-phase reaction in which, upon cooling, two solid phases transform to give a third solid phase.

### **The Iron-Carbon Equilibrium Diagram**

A study of the constitution and structure of all steels and irons must first start with the iron-carbon equilibrium diagram. Many of the basic features of this system (Fig. 1) influence the behavior of even the most complex alloy steels. For example, the phases found in the simple binary Fe-C system persist in complex steels, but it is necessary to examine the effects alloying elements have on the formation and properties of these phases. The iron-carbon diagram provides a valuable foundation on which to build knowledge of both plain carbon and alloy steels in their immense variety.

It should first be pointed out that the normal equilibrium diagram really represents the metastable equilibrium between iron and iron carbide (cementite). Cementite is metastable, and the true equilibrium should be between iron and graphite. Although graphite occurs extensively in cast irons (2-4 wt % C), it is usually difficult to obtain this equilibrium phase in steels (0.03-1.5 wt % C). Therefore, the metastable equilibrium between iron and iron carbide should be considered, because it is relevant to the behavior of most steels in practice. The much larger phase field of  $\gamma$ -iron (austenite) compared with that of  $\alpha$ -iron (ferrite) reflects the much greater solubility of carbon in  $\gamma$ -iron, with a maximum value of just over 2 wt % at 1147°C (E, Fig.1). This high solubility of carbon in  $\gamma$ -iron is of extreme importance in heat

treatment, when solution treatment in the  $\gamma$ -region followed by rapid quenching to room temperature allows a supersaturated solid solution of carbon in iron to be formed. The  $\alpha$ -iron phase field is severely restricted, with a maximum carbon solubility of 0.02 wt% at 723°C (P), so over the carbon range encountered in steels from 0.05 to 1.5 wt%,  $\alpha$ -iron is normally associated with iron carbide in one form or another. Similarly, the  $\delta$ -phase field is very restricted between 1390 and 1534°C and disappears completely when the carbon content reaches 0.5 wt% (B). There are several temperatures or critical points in the diagram, which are important, both from the basic and from the practical point of view.

- Firstly, there is the  $A_1$ , temperature at which the eutectoid reaction occurs (P-S-K), which is 723°C in the binary diagram.
- Secondly, there is the  $A_3$ , temperature when  $\alpha$ -iron transforms to  $\gamma$ -iron. For pure iron this occurs at 910°C, but the transformation temperature is progressively lowered along the line GS by the addition of carbon.
- The third point is  $A_4$  at which  $\gamma$ -iron transforms to  $\delta$ -iron, 1390°C in pure iron, but this is raised as carbon is added. The  $A_2$ , point is the Curie point when iron changes from the ferro- to the paramagnetic condition. This temperature is 769°C for pure iron, but no change in crystal structure is involved. The  $A_1$ ,  $A_3$  and  $A_4$  points are easily detected by thermal analysis or dilatometry during cooling or heating cycles, and some hysteresis is observed. Consequently, three values for each point can be obtained.  $A_c$  for heating,  $A_r$  for cooling and  $A_e$  (equilibrium), but it should be emphasized that the  $A_c$  and  $A_r$  values will be sensitive to the rates of heating and cooling, as well as to the presence of alloying elements.

The great difference in carbon solubility between  $\gamma$ - and  $\alpha$ -iron leads normally to the rejection of carbon as iron carbide at the boundaries of the  $\gamma$  phase field. The transformation of  $\gamma$  to  $\alpha$  - iron occurs via a eutectoid reaction, which plays a dominant role in heat treatment.

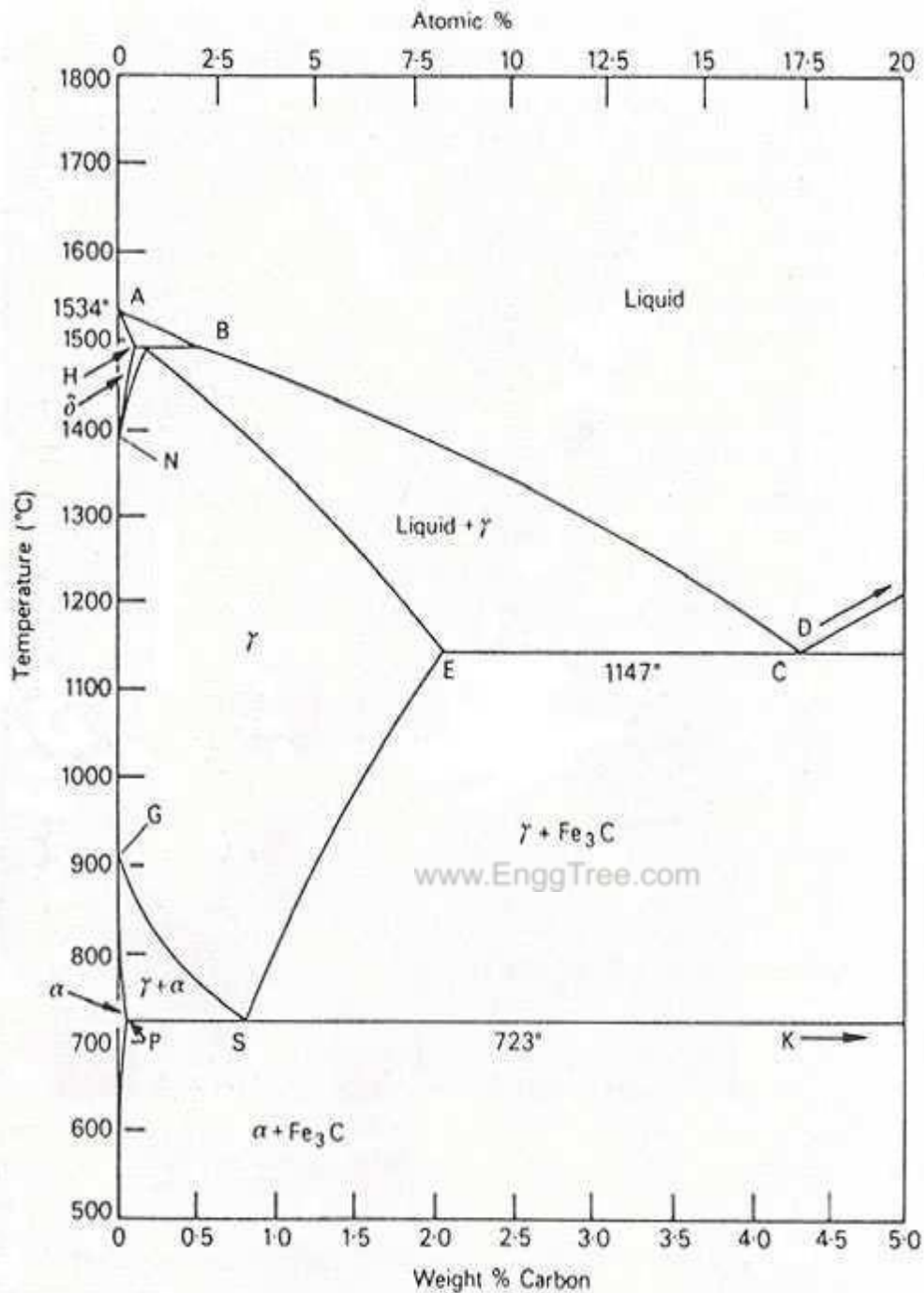

The eutectoid temperature is 723°C while the eutectoid composition is 0.80% C(s). On cooling alloys containing less than 0.80% C slowly, hypo-eutectoid ferrite is formed from austenite in the range 910-723°C with enrichment of the residual austenite in carbon, until at 723°C the remaining austenite, now containing 0.8% carbon transforms to pearlite, a lamellar mixture of ferrite and iron carbide (cementite). In austenite with 0.80 to 2.06% carbon, on cooling slowly in the temperature interval 1147°C to 723°C, cementite first forms progressively depleting the austenite in carbon, until at 723°C, the austenite contains 0.8% carbon and transforms to pearlite.

Steels with less than about 0.8% carbon are thus hypo-eutectoid alloys with ferrite and pearlite as the prime constituents, the relative volume fractions being determined by the lever rule which states that as the carbon content is increased, the volume percentage of pearlite increases, until it is 100% at the eutectoid composition. Above 0.8% C, cementite becomes the hyper-eutectoid phase, and a similar variation in volume fraction of cementite and pearlite occurs on this side of the eutectoid composition. The three phases, ferrite, cementite and pearlite are thus the principle constituents of the infrastructure of plain carbon steels, provided they have been subjected to relatively slow cooling rates to avoid the formation of metastable phases.

#### The austenite- ferrite transformation

Under equilibrium conditions, pro-eutectoid ferrite will form in iron-carbon alloys containing up to 0.8 % carbon. The reaction occurs at 910°C in pure iron, but takes place between 910°C and 723°C in iron-carbon alloys.

However, by quenching from the austenitic state to temperatures below the eutectoid temperature  $Ae_1$ , ferrite can be formed down to temperatures as low as 600°C. There are pronounced morphological changes as the transformation temperature is lowered, which it should be emphasized apply in general to hypo-and hyper-eutectoid phases, although in each case there will be variations due to the precise crystallography of the phases involved. For example, the same principles apply to the formation of cementite from austenite, but it is not difficult to distinguish ferrite from cementite morphologically.

#### The austenite-cementite transformation

The Dube classification applies equally well to the various morphologies of cementite formed at progressively lower transformation temperatures. The initial development of grain boundary allotriomorphs is very similar to that of ferrite, and the growth of side plates or Widmanstatten cementite follows the same pattern. The cementite plates are more rigorously crystallographic in form, despite the fact that the orientation relationship with austenite is a more complex one. As in the case of ferrite, most of the side plates originate from grain boundary allotriomorphs, but in the cementite reaction more side plates nucleate at twin boundaries in austenite.

#### The austenite-pearlite reaction

Pearlite is probably the most familiar micro structural feature in the whole science of metallography. It was discovered by Sorby over 100 years ago, who correctly assumed it to be a lamellar mixture of iron and iron carbide. Pearlite is a very common constituent of a wide variety of steels, where it provides a substantial contribution to strength. Lamellar eutectoid structures of this type are widespread in metallurgy, and frequently pearlite is used as a generic term to describe them. These structures have much in common with the cellular precipitation reactions. Both types of reaction occur by nucleation and growth, and are, therefore, diffusion controlled. Pearlite nuclei occur on austenite grain boundaries, but it is clear that they can also be associated with both pro- eutectoid ferrite and cementite. In commercial steels, pearlite nodules can nucleate on inclusions.

## Classification of Carbon and Low-Alloy Steel

The American Iron and Steel Institute (AISI) defines carbon steel as follows: Steel is considered to be carbon steel when no minimum content is specified or required for chromium, cobalt, columbium [niobium], molybdenum, nickel, titanium, tungsten, vanadium or zirconium, or any other element to be added to obtain a desired alloying effect; when the specified minimum for copper does not exceed per cent; or when the maximum content specified for any of the following elements does not exceed the percentages noted: manganese 1.65, silicon 0.60, copper 0.60.

Steels can be classified by a variety of different systems depending on:

- The composition, such as carbon, low-alloy or stainless steel.
- The manufacturing methods, such as open hearth, basic oxygen process, or electric furnace methods.
- The finishing method, such as hot rolling or cold rolling
- The product form, such as bar plate, sheet, strip, tubing or structural shape
- The deoxidation practice, such as killed, semi-killed, capped or rimmed steel
- The microstructure, such as ferritic, pearlitic and martensitic
- The required strength level, as specified in ASTM standards
- The heat treatment, such as annealing, quenching and tempering, and thermomechanical processing
- Quality descriptors, such as forging quality and commercial quality.

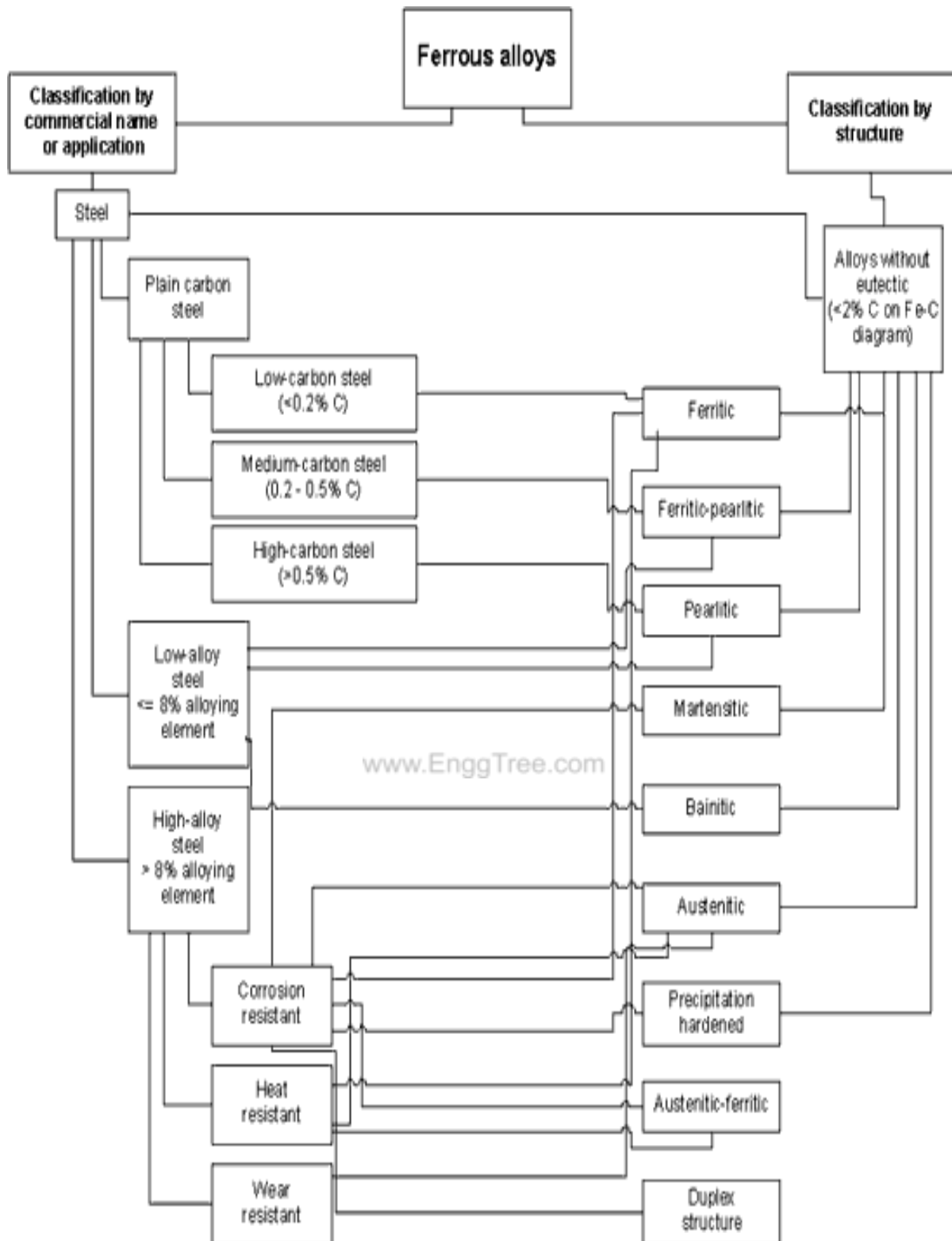



The American Iron and Steel Institute (AISI) defines carbon steel as follows:

Steel is considered to be carbon steel when no minimum content is specified or required for chromium, cobalt, columbium [niobium], molybdenum, nickel, titanium, tungsten, vanadium or zirconium, or any other element to be added to obtain a desired alloying effect; when the specified minimum for copper does not exceed 0.40 per cent; or when the maximum content specified for any of the following elements does not exceed the percentages noted: manganese 1.65, silicon 0.60, copper 0.60. Carbon steel can be classified, according to various deoxidation practices, as rimmed, capped, semi-killed, or killed steel. Deoxidation practice and the steelmaking process will have an effect on the properties of the steel. However, variations in carbon have the greatest effect on mechanical properties, with increasing carbon content leading to increased hardness and strength. As such, carbon steels are generally categorized according to their carbon content. Generally speaking, carbon steels contain up to 2% total alloying elements and can be subdivided into low-carbon steels, medium-carbon steels, high-carbon steels, and ultrahigh-carbon steels; each of these designations is discussed below. As a group, carbon steels are by far the most frequently used steels. More than 85% of the steel produced and shipped in the United States is carbon steel.

Low-carbon steels contain up to 0.30% C. The largest category of this class of steel is flat-rolled products (sheet or strip), usually in the cold-rolled and annealed condition. The carbon content for these high-formability steels is very low, less than 0.10% C, with up to 0.4% Mn. Typical uses are in automobile body panels, tin plate, and wire products. For rolled steel structural plates and sections, the carbon content may be increased to approximately 0.30%, with higher manganese content up to 1.5%. These materials may be used for stampings, forgings, seamless tubes, and boiler plate.

Medium-carbon steels are similar to low-carbon steels except that the carbon ranges from 0.30 to 0.60% and the manganese from 0.60 to 1.65%. Increasing the carbon content to approximately 0.5% with an accompanying increase in manganese allows medium carbon steels to be used in the quenched and tempered condition. The uses of medium carbon-manganese steels include shafts, axles, gears, crankshafts, couplings and forgings. Steels in the 0.40 to 0.60% C range are also used for rails, railway wheels and rail axles.

High-carbon steels contain from 0.60 to 1.00% C with manganese contents ranging from 0.30 to 0.90%. High-carbon steels are used for spring materials and high-strength wires.

Ultrahigh-carbon steels are experimental alloys containing 1.25 to 2.0% C. These steels are thermo mechanically processed to produce microstructures that consist of ultrafine, equiaxed grains of spherical, discontinuous proeutectoid carbide particles.

## Types of Cast Iron:

Major types of cast iron are shown in Figure 1.4

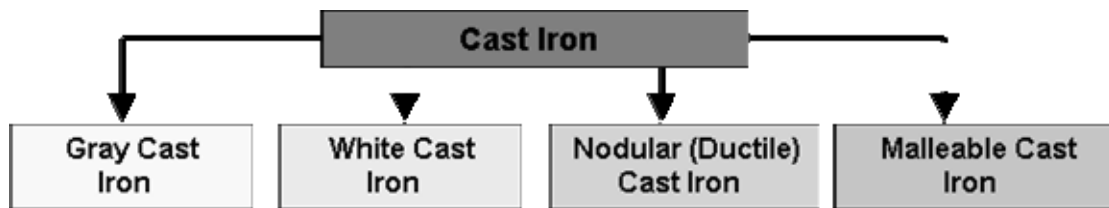

Figure 1.4 Types of Cast Iron

## Gray Cast Iron:

Gray cast iron is by far the oldest and most common form of cast iron. As a result, it is assumed by many to be the only form of cast iron and the terms "cast iron" and "gray iron" are used interchangeably. Unfortunately the only commonly known property of gray iron- brittleness- is also assigned to "cast iron" and hence to all cast irons. Gray iron, named because its fracture has a gray appearance. It contains carbon in the form of flake graphite in a matrix which consists of ferrite, pearlite or a mixture of the two. The fluidity of liquid gray iron, and its expansion during solidification due to the formation of graphite, have made this metal ideal for the economical production of shrinkage-free, intricate castings such as motor blocks. The flake-like shape of graphite in Gray iron, see Figures 1.5 and 1.6, exerts a dominant influence on its mechanical properties. The graphite flakes act as stress raisers which may prematurely cause localized plastic flow at low stresses, and initiate fracture in the matrix at higher stresses. As a result, Gray iron exhibits no elastic behavior but excellent damping characteristics, and fails in tension without significant plastic deformation. The presence of graphite flakes also gives Gray Iron excellent machinability and self-lubricating properties.



Figure 1.5 Graphite Flakes in Gray Cast iron



Figure 1.6 Photomicrograph of Gray Cast iron

#### Advantages of Gray Cast Iron:

- Graphite acts as a chip breaker and a tool lubricant. Very high damping capacity.
- Good dry bearing qualities due to graphite. After formation of protective scales, it resists corrosion in many common engineering environments.

#### Disadvantages:

Brittle (low impact strength) which severely limits use for critical applications. Graphite acts as a void and reduces strength. Maximum recommended design stress is  $1/4$  of the ultimate tensile strength. Maximum fatigue loading limit is  $1/3$  of fatigue strength. Changes in section size will cause variations in machining characteristics due to variation in microstructure. Higher strength gray cast irons are more expensive to produce.

#### Low Alloy Gray Cast Iron:

Enables gray cast iron to be used in higher duty applications without redesign or need for costly materials.

#### Advantages:

- Reduction in section sensitivity.
- Improvement in strength, corrosion resistance, heat and wear resistance or combination of these properties.

#### Disadvantages:

- Higher cost.
- Alloy additions can cause foundry problems with reuse of scrap (runners, risers, etc) and interrupt normal production.
- Increase in strength does not bring corresponding increase in fatigue strength.
- Cr, Mo and V are carbide stabilizers which improve strength and heat resistance but impair machinability.

#### White Cast Iron:

White cast iron is unique in that it is the only member of the cast iron family in which carbon is present only as carbide. Due to the absence of graphite, it has a light appearance. The presence of different carbides, depending on the alloy content, makes white cast irons extremely hard and abrasion resistant but very brittle. An improved form of white cast iron is the chilled cast iron.

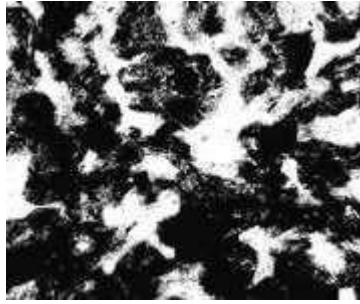

Figure 1.7 Photomicrograph of White Cast Iron

#### Chilled Cast Iron:

When localized area of a gray cast iron is cooled very rapidly from the melt, cast iron is formed at the place that has been cooled. This type of white cast iron is called chilled iron. A chilled iron casting can be produced by adjusting the carbon composition of the white cast iron so that the normal cooling rate at the surface is just fast enough to produce white cast iron while the slower cooling rate below the surface will produce gray iron. The depth of chill decreases and the hardness of the chilled zone increases with increasing carbon content.

Chromium is used in small amounts to control chill depth. Because of the formation of chromium carbides, chromium is used in amount of 1 to 4 percent in chilled iron to increase hardness and improve abrasion resistance. It also stabilizes carbide and suppresses the formation of graphite in heavy sections. When added in amounts of 12 to 35 percent, chromium will impart resistance to corrosion and oxidation at elevated temperatures.

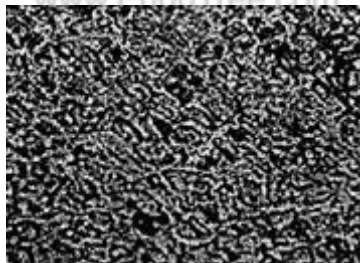

Figure 1.8 Photomicrograph of Chilled Cast Iron

Fast cooling prevents graphite and pearlite formation. If alloys such as nickel, chromium, or molybdenum are added, much of the austenite transforms to martensite instead of pearlite. The hardness of chilled cast iron is generally due to the formation of martensite.

Chilled cast iron is used for railway-car wheels, crushing rolls, stamp shoes and dies, and many heavy-duty machinery parts.

#### Ductile Cast Iron (Nodular Cast Iron):

This structure is developed from the melt. The carbon forms into spheres when cerium, magnesium, sodium, or other elements are added to a melt of iron with a very low sulfur content that will inhibit carbon from forming. The control of the heat-treating process can yield pearlitic, ferritic, martensitic matrices into which the carbon spheres are embedded.

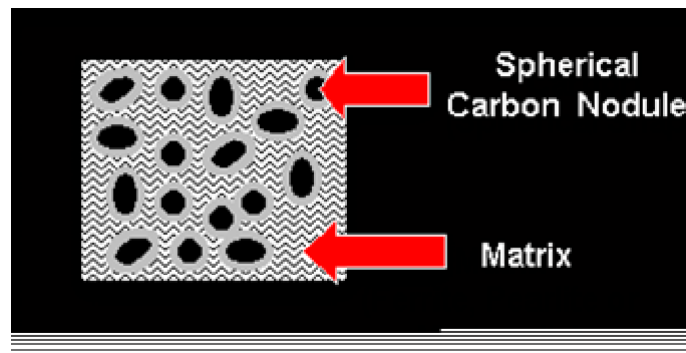

Figure 1.9. Nodular (Ductile) Cast Iron and the spherical carbon embedded into the matrix.

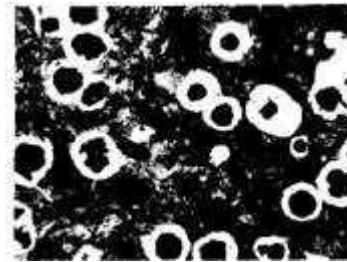

Figure 1.10 Photomicrograph of Nodular Cast iron

The advantages of ductile cast iron which have led to its success are numerous, but they can be summarized easily- versatility and high performance at low cost. Other members of the ferrous casting family may have superior individual properties which might make them the material of choice in some applications, but none have the versatility of ductile cast iron, which often provides the designer with the best combination of overall properties. This is especially evident in the area of mechanical properties where ductile cast iron offers the designer the option of selecting high ductility, with grades guaranteeing more than 18% elongation (as high as 25 %), or high strength, with tensile strengths exceeding 120 Ksi. Austempered ductile iron offers even greater mechanical and wear resistance, providing tensile strengths exceeding 230 Ksi. In addition to cost advantages offered by all castings, ductile cast iron, when compared to steel and malleable cast iron, also offers further cost savings. Like most commercial cast metal, steel and malleable cast iron decrease in volume during solidification, and as a result, require feeders and risers to offset the shrinkage and prevent the formation of internal or external shrinkage defects. Ductile cast iron offers significantly low shrinkage during casting. In the case of large castings produced in rigid molds, it does not require feeders. In other cases, it requires feeders that are much smaller than those used for malleable cast iron and steel. This reduced requirement for feed metal increases the productivity of ductile cast iron and reduces its material and energy requirements, resulting in substantial cost savings. The use of the most common grades of ductile cast iron "as- cast" eliminates heat treatment costs, offering a further advantage.

Ductile cast iron is used for many structural applications, particularly those requiring strength and toughness combined with good machinability and low cost. The automotive and agricultural industries are the major users of ductile iron castings. Because of economic advantage and high reliability, ductile iron is used for such critical automotive parts as crankshafts, engine connecting rods, idler arms, wheel hubs, truck axles, front wheel spindle supports, disk brake calipers, suspension system parts, power transmission yokes, high temperature applications for turbo housing and manifolds, and high security valves for many applications. The cast iron pipe industry is another major user of ductile iron.

### Malleable Cast Iron:

If cast iron is cooled rapidly, the graphite flakes needed for gray cast iron do not get a chance to form. Instead, white cast iron forms. This white cast iron is reheated to about 1700°F for long periods of time in the presence of materials containing oxygen, such as iron oxide. At the elevated temperatures cementite ( $\text{Fe}_3\text{C}$ ) decomposes into ferrite and free carbon. Upon cooling, the combined carbon further decomposes to small compact particles of graphite (instead of flake-like graphite seen in gray cast iron). If the cooling is very slow, more free carbon is released. This free carbon is referred to as temper carbon, and the process is called malleableizing.

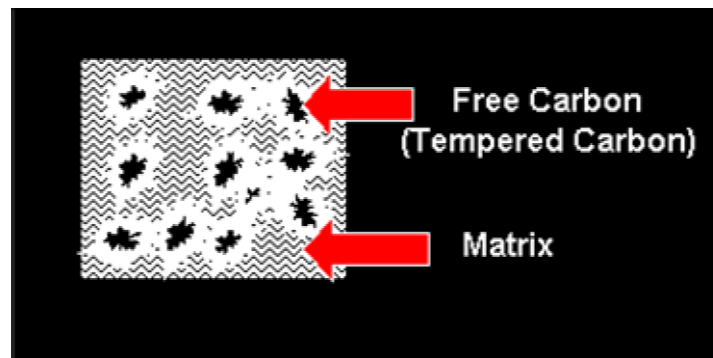

Figure 1.11 Malleable Cast Iron

Figure 8 shows ferritic malleable cast iron, which has a ferrite matrix and the tempered carbon particles are embedded into the matrix.

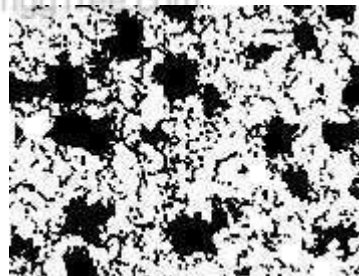

Figure 1.12 Ferritic Malleable Cast iron

Figure 9 shows pearlitic malleable cast iron, which has a pearlite matrix. By adding manganese to the structure, carbon is retained in the form of cementite.

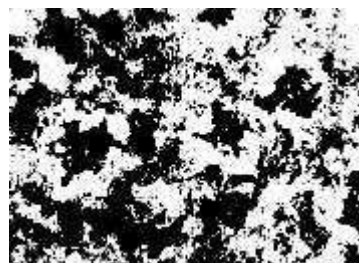

Figure 1.13. Pearlitic Malleable Cast Iron

A wide variety of physical properties can be obtained by heating and cooling through the eutectoid temperature or by adding alloying elements. Slow cooling will cause the cementite to decompose and release more free carbon (temper carbon). Fast cooling will retain some of the cementite. The amount retained, will depend on the rapidity of cooling. Malleable cast iron is used for connecting rods and universal joint yokes, transmission gears, differential cases and certain gears, compressor crankshafts and hubs, flanges, pipe fittings and valve parts for railroad, marine and other heavy-duty applications.

Advantages:

- Excellent machinability Significant ductility
- Good shock resistance properties

Disadvantages:

The major disadvantage is shrinkage. Malleable cast iron decreases in volume during solidification, and as a result, requires attached reservoirs (feeders and risers) of liquid metal to offset the shrinkage and prevent the formation of internal or external shrinkage defects.

## Unit – II HEAT TREATMENT

The Fe-C Phase Diagram

Isothermal transformation diagrams

CCT Diagrams (Cooling Curve)

Full Annealing

Recrystallization and Spheroidising

Normalizing

Hardening

Tempering Austempering and Martempering

Hardenability and Jominy End Quench Test

Case hardening carburizing

Nitriding and Cyaniding

Carbonitriding

[www.EnggTree.com](http://www.EnggTree.com)

Flame Hardening

Induction Hardening

Vacuum and Plasma hardening



Steel is usually defined as an alloy of iron and carbon with the carbon content between a few hundredths of a percent up to about 2 wt%. Other alloying elements can amount in total to about 5 wt% in low-alloy steels and higher in more highly alloyed steels such as tool steels, stainless steels (>10.5%) and heat resisting CrNi steels (>18%). Steels can exhibit a wide variety of properties depending on composition as well as the phases and micro-constituents present, which in turn depend on the heat treatment.

### The Fe-C Phase Diagram

The basis for the understanding of the heat treatment of steels is the Fe-C phase diagram (Fig 2.1). Figure 2.1 actually shows two diagrams; the stable iron-graphite diagram (dashed lines) and the metastable Fe-Fe<sub>3</sub>C diagram. The stable condition usually takes a very long time to develop, especially in the low-temperature and low-carbon range, and therefore the metastable diagram is of more interest. The Fe-C diagram shows which phases are to be expected at equilibrium (or metastable equilibrium) for different combinations of carbon concentration and temperature.

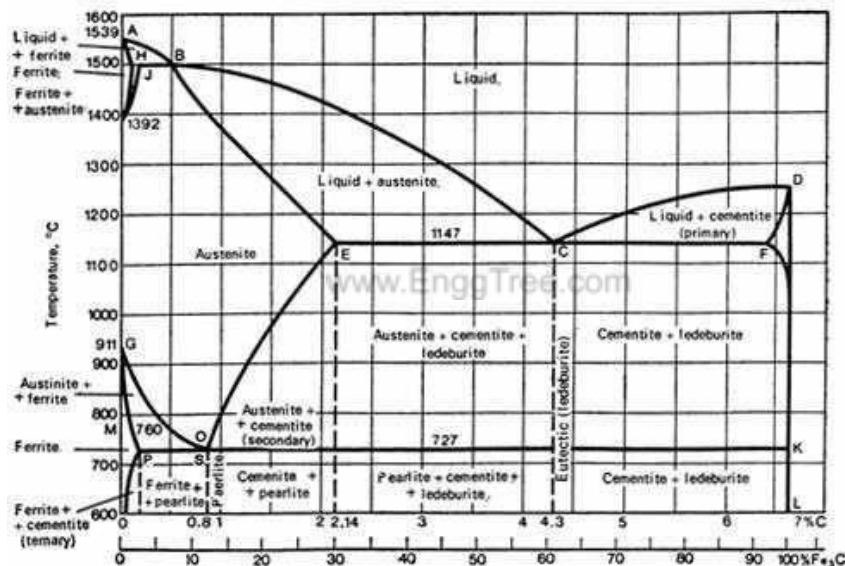

We distinguish at the low-carbon end ferrite ( $\alpha$ -iron), which can at most dissolve 0.028% C, at 727°C (1341°F) and austenite -iron, which can dissolve 2.11 wt% C at 1148°C (2098°F). At the carbon-rich side we find cementite (Fe<sub>3</sub>C). Of less interest, except for highly alloyed steels, is the  $\delta$ -ferrite existing at the highest temperatures. Between the single-phase fields are found regions with mixtures of two phases, such as ferrite + cementite, austenite + cementite, and ferrite + austenite. At the highest temperatures, the liquid phase field can be found and below this are the two phase fields liquid + austenite, liquid + cementite, and liquid +  $\delta$ -ferrite.

In heat treating of steels, the liquid phase is always avoided. Some important boundaries at single-phase fields have been given special names:

- A<sub>1</sub>, the so-called eutectoid temperature, which is the minimum temperature for austenite
- A<sub>3</sub>, the lower-temperature boundary of the austenite region at low carbon contents, that is, the  $\gamma/\gamma + \alpha$  boundary

- $A_{cm}$ , the counterpart boundary for high carbon contents, that is, the  $\gamma/\gamma + Fe_3C$  boundary

The carbon content at which the minimum austenite temperature is attained is called the eutectoid carbon content (0.77 wt% C). The ferrite-cementite phase mixture of this composition formed during cooling has a characteristic appearance and is called pearlite and can be treated as a micro structural entity or micro constituent. It is an aggregate of alternating ferrite and cementite lamellae that degenerates into cementite particles dispersed with a ferrite matrix after extended holding close to  $A_1$ .

The Fe-C diagram in Fig 2.1 is of experimental origin. The knowledge of the thermodynamic principles and modern thermodynamic data now permits very accurate calculations of this diagram. This is particularly useful when phase boundaries must be extrapolated and at low temperatures where the experimental equilibrium are extremely slow to develop.

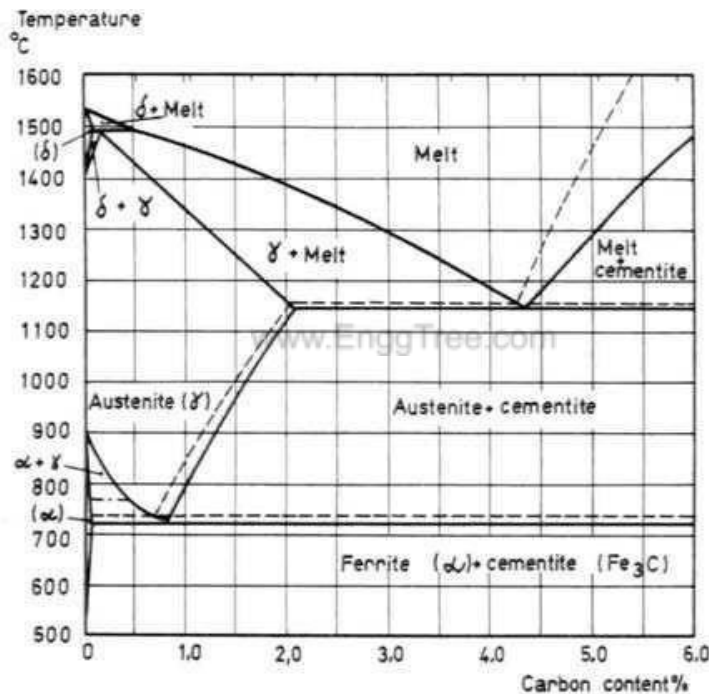

If alloying elements are added to the iron-carbon alloy (steel), the position of the  $A_1$ ,  $A_3$ , and  $A_{cm}$  boundaries and the eutectoid composition are changed. It suffices here to mention that

1. all important alloying elements decrease the eutectoid carbon content,
2. the austenite-stabilizing elements manganese and nickel decrease  $A_1$ , and
3. the ferrite-stabilizing elements chromium, silicon, molybdenum, and tungsten increase  $A_1$ .

### Transformation Diagrams

The kinetic aspects of phase transformations are as important as the equilibrium diagrams for the heat treatment of steels. The metastable phase martensite and the morphologically metastable micro constituent bainite, which are of extreme importance

to the properties of steels, can generally form with comparatively rapid cooling to ambient temperature. That is when the diffusion of carbon and alloying elements is suppressed or limited to a very short range.

Bainite is a eutectoid decomposition that is a mixture of ferrite and cementite. Martensite, the hardest constituent, forms during severe quenches from supersaturated austenite by a shear transformation. Its hardness increases monotonically with carbon content up to about 0.7 wt%. If these unstable metastable products are subsequently heated to a moderately elevated temperature, they decompose to more stable distributions of ferrite and carbide. The reheating process is sometimes known as tempering or annealing.

The transformation of an ambient temperature structure like ferrite-pearlite or tempered martensite to the elevated-temperature structure of austenite or austenite-carbide is also of importance in the heat treatment of steel. One can conveniently describe what is happening during transformation with transformation diagrams. Four different types of such diagrams can be distinguished. These include:

- Isothermal transformation diagrams describing the formation of austenite, which will be referred to as IT diagrams
- Isothermal transformation (IT) diagrams, also referred to as time-temperature-transformation (TTT) diagrams, describing the decomposition of austenite
- Continuous heating transformation (CHT) diagrams
- Continuous cooling transformation (CCT) diagrams

### ISOTHERMAL TRANSFORMATION DIAGRAMS

This type of diagram shows what happens when a steel is held at a constant temperature for a prolonged period. The development of the microstructure with time can be followed by holding small specimens in a lead or salt bath and quenching them one at a time after increasing holding times and measuring the amount of phases formed in the microstructure with the aid of a microscope. IT Diagrams (Formation of Austenite). During the formation of austenite from an original microstructure of ferrite and pearlite or tempered martensite, the volume decreases with the formation of the dense austenite phase. From the elongation curves, the start and finish times for austenite formation, usually defined as 1% and 99% transformation, respectively, can be derived

IT Diagrams (Decomposition of Austenite). The procedure starts at a high temperature, normally in the austenitic range after holding there long enough to obtain homogeneous austenite without undissolved carbides, followed by rapid cooling to the desired hold temperature. The cooling was started from 850°C (1560°F). The A<sub>1</sub> and A<sub>3</sub> temperatures are indicated as well as the hardness. Above A<sub>3</sub> no transformation can occur. Between A<sub>1</sub> and A<sub>3</sub> only ferrite can form from austenite.

#### CRT Diagrams

In practical heat treatment situations, a constant temperature is not required, but rather a continuous changing temperature during either cooling or heating. Therefore, more directly applicable information is obtained if the diagram is constructed from dilatometric data using a continuously increasing or decreasing temperature. Like the IT diagrams, the CRT diagrams are useful in predicting the effect of short-time

austenitization that occurs in induction and laser hardening. One typical question is how high the maximum surface temperature should be in order to achieve complete austenitization for a given heating rate. Too high a temperature may cause unwanted austenite grain growth, which produces a more-brittle martensitic microstructure.

### CCT Diagrams

As for heating diagrams, it is important to clearly state what type of cooling curve the transformation diagram was derived from. Use of a constant cooling rate is very common in experimental practice. However, this regime rarely occurs in a practical situation. One can also find curves for so-called natural cooling rates according to Newton's law of cooling. These curves simulate the behavior in the interior of a large part such as the cooling rate of a Jominy bar at some distance from the quenched end. Close to the surface the characteristics of the cooling curve can be very complex. Each CCT diagram contains a family of curves representing the cooling rates at different depths of a cylinder with a 300 mm (12 in.) diameter. The slowest cooling rate represents the center of the cylinder. The more severe the cooling medium, the longer the times to which the C-shaped curves are shifted. The  $M_s$  temperature is unaffected.

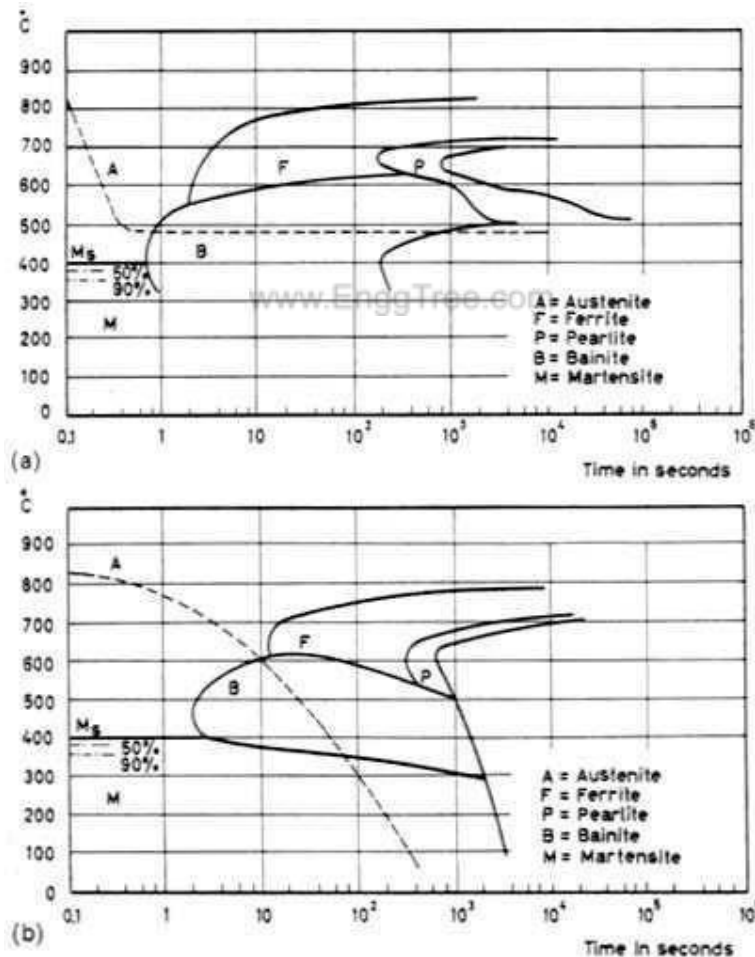

Fig.2.2 CCT (a) and TTT (b) diagrams.

It should be noted, however, that transformation diagrams can not be used to predict the response to thermal histories that are very much different from the ones used to construct the diagrams. For instance, first cooling rapidly to slightly above  $M_s$  and then reheating to a higher temperature will give more rapid transformation than shown in the

IT diagram because nucleation is greatly accelerated during the introductory quench. It should also be remembered that the transformation diagrams are sensitive to the exact alloying content within the allowable composition range.

### Full Annealing

The purpose of annealing may involve one or more of the following aims:

1. To soften the steel and to improve machinability.
2. To relieve internal stresses induced by some previous treatment (rolling, forging, uneven cooling).
3. To remove coarseness of grain.

The treatment is applied to forgings, cold-worked sheets and wire, and castings. The operation consists of:

- Heating the steel to a certain temperature,
- "Soaking" at this temperature for a time sufficient to allow the necessary changes to occur,
- Cooling at a predetermined rate.

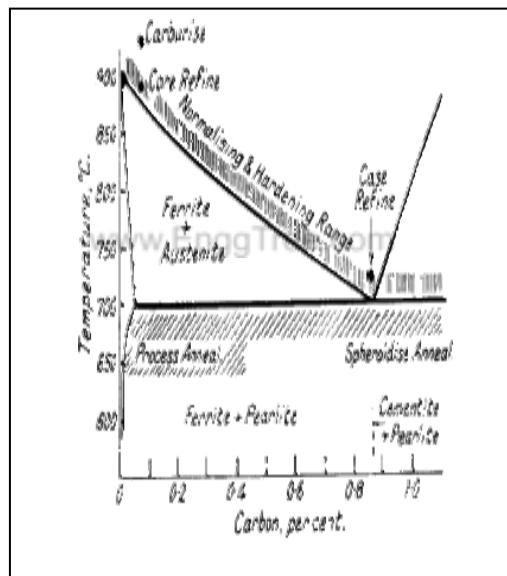

### Sub-critical Anneal

It is not always necessary to heat the steel into the critical range. Mild steel products which have to be repeatedly cold worked in the processes of manufacture are softened by annealing at 500° to 650°C for several hours. This is known as "process" or "close" annealing, and is commonly employed for wire and sheets. The recrystallisation temperature of pure iron is in the region of 500°C consequently the higher temperature of 650°C brings about rapid recrystallisation of the distorted ferrite. Since mild steel contains only a small volume of strained pearlite a high degree of softening is induced. As shown, Fig. 1b illustrates the structure formed consisting of the polyhedral ferrite with elongated pearlite (see also Fig. 2.3).

Prolonged annealing induces greater ductility at the expense of strength, owing to the tendency of the cementite in the strained pearlite to "ball-up" or spheroidise, as illustrated in Fig. 2.3. This is known as "divorced pearlite". The ferrite grains also

become larger, particularly if the metal has been cold worked a critical amount. A serious embrittlement sometimes arises after prolonged treatment owing to the formation of cementitic films at the ferrite boundaries. With severe forming operations, cracks are liable to start at these cementite membranes.

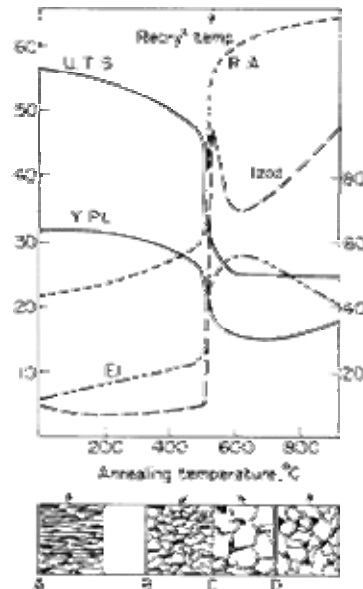

Figure 2.3 Effect of annealing cold-worked mild steel



Figure 2.4 Effect of annealing at 650°C on worked steel. Ferrite recrystallised. Pearlite remains elongated (x600)

The modern tendency is to use batch or continuous annealing furnaces with an inert purging gas. Batch annealing usually consists of 24-30 hrs 670°C, soak 12 hrs, slow cool 4-5 days. Open coil annealing consists in recoiling loosely with controlled space between wraps and it reduces stickers and discoloration. Continuous annealing is used for thin strip (85% Red) running at about 400 m/min. The cycle is approximately up to 660°C 20 sec, soak and cool 30-40 sec. There is little chance for grain growth and it produces harder and stiffer strip; useful for cans and panelling. "Double reduced" steel is formed by heavy reduction (~50%) after annealing but it suffers from directionality. This can be eliminated by heating between 700-920°C and rapidly quenching.

**Spheroidize Annealing**

Spheroidize annealing is applicable to steels which have more than 0.8% carbon. Parts are heated to between 1150°F and 1200°F and holding it at this temperature for a period of time to convert the microstructure. Essentially, cementite changes from a lamella formation to an alpha ferrite matrix with particles of spheroidal cementite (Fe<sub>3</sub>C). Spheroidize annealing is generally done on parts which have been work hardened, to allow them to be further worked, either rolled in the case of coils, or drawn for wire. This resulting product has improved ductility and toughness with reduced hardness and strength. Spheroidize annealing is normally carried out under a protective (endothermic) atmosphere to prevent oxidation and decarburization.

**Normalizing**

For steels with less than 0.9% carbon both treatments consist in heating to about 25-50°C above the upper critical point indicated by the Fe-Fe<sub>3</sub>C equilibrium diagram (Fig. 2.1). For higher carbon steels the temperature is 50°C above the lower critical point.

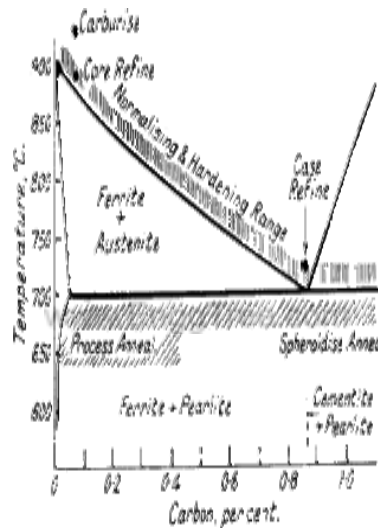

Figure 2.5 Heat-treatment ranges of steels Average annealing and hardening

temperatures are:

Carbon, %	0	0	0	0	0	0.9 to 1.3
Avg.temp. °C	910	810	810	810	760	760

These temperatures allow for the effects of slight variations in the impurities present and also the thermal lag associated with the critical changes. After soaking at the temperature for a time dependent on the thickness of the article, the steel is very slowly cooled. This treatment is known as full annealing, and is used for removing strains from

forgings and castings, improving machinability and also when softening and refinement of structure are both required.

*Normalizing* differs from the full annealing in that the metal is allowed to cool in *still air*. The structure and properties produced, however, varying with the thickness of metal treated. The tensile strength, yield point, reduction of area and impact value are higher than the figures obtained by annealing.

#### Changes on Annealing

Consider the heating of a 0,3% carbon steel. At the lower critical point ( $A_{c1}$ ) each "grain" of pearlite changes to several minute austenite crystals and as the temperature is raised the excess ferrite is dissolved, finally disappearing at the upper critical point ( $A_{c3}$ ), still with the production of fine austenite crystals. Time is necessary for the carbon to become uniformly distributed in this austenite. The properties obtained subsequently depend on the coarseness of the pearlite and ferrite and their relative distribution. These depend on:

- a) the size of the austenite grains; the smaller their size the better the distribution of the ferrite and pearlite.
- b) the rate of cooling through the critical range, which affects both the ferrite and the pearlite.

As the temperature is raised above  $A_{c3}$  the crystals increase in size. On a certain temperature the growth, which is rapid at first, diminishes. Treatment just above the upper critical point should be aimed at, since the austenite crystals are then small.

By cooling slowly through the critical range, ferrite commences to deposit on a few nuclei at the austenite boundaries. Large rounded ferrite crystals are formed, evenly distributed among the relatively coarse pearlite. With a higher rate of cooling, many ferrite crystals are formed at the austenite boundaries and a network structure of small ferrite crystals is produced with fine pearlite in the centre. Overheated, Burnt and Under annealed Structures When the steel is heated well above the upper critical temperature large austenite crystals form. Slow cooling gives rise to the Widmanstätten type of structure, with its characteristic lack of both ductility and resistance to shock. This is known as an overheated structure, and it can be refined by reheating the steel to just above the upper critical point. Surface decarburisation usually occurs during the overheating.

During the Second World War, aircraft engine makers were troubled with overheating (above  $1250^{\circ}\text{C}$ ) in drop-stampings made from alloy steels. In the hardened and tempered condition the fractured surface shows dull facets. The minimum overheating temperature depends on the "purity" of the steel and is substantially lower in general for electric steel than for open-hearth steel. The overheated structure in these alloy steels occurs when they are cooled at an intermediate rate from the high temperature. At faster or slower rates the overheated structure may be eliminated. This, together with the fact that the overheating temperature is significantly raised in the presence of high contents of MnS and inclusions, suggests that this overheating is connected in some way with a diffusion and precipitation process, involving MnS. This type of overheating can occur in an atmosphere free from oxygen, thus emphasizing the difference between overheating and burning. As the steel approaches the solids temperature, incipient fusion and oxidation take place at the grain boundaries. Such steel is said to be burnt



and it is characterized by the presence of brittle iron oxide films, which render the steel unfit for service, except as scrap for remelting.

### **HARDENING:**

The ability to be hardened varies with the carbon and alloy content of steel. The higher the carbon content the harder the steel can become. Low carbon steel has very low hardenability and wrought iron which has no carbon is unhardenable. To harden steel it is heated above the "transformation point", a low red or just above where the steel becomes non-magnetic. Then it is quenched in brine, water, oil or even air. Afterwards it is tempered by reheating. This reduces the brittleness of the steel a lot and the hardness just a little. Temper temperatures range from as low as 350°F to as high as 1400°F depending on the steel. The quenchant depends on the type of steel. In general quenching in a more severe quenchant than necessary can cause cracks in the steel. Overheating prior to the quench can do the same. In general hard parts are always more brittle than soft parts. Using parts that are too hard can be dangerous. On machines this can mean parts that may explode or shatter.

Hardening /annealing silver ( Refer it)

### **Time-Temperature-Transformation (TTT ) Diagram**

T (Time) T(Temperature) T(Transformation) diagram is a plot of temperature versus the logarithm of time for a steel alloy of definite composition. It is used to determine when transformations begin and end for an isothermal (constant temperature) heat treatment of a previously austenitized alloy. When austenite is cooled slowly to a temperature below LCT (Lower Critical Temperature), the structure that is formed is Pearlite. As the cooling rate increases, the pearlite transformation temperature gets lower. The microstructure of the material is significantly altered as the cooling rate increases. By heating and cooling a series of samples, the history of the austenite transformation may be recorded. TTT diagram indicates when a specific transformation starts and ends and it also shows what percentage of transformation of austenite at a particular temperature is achieved.

Cooling rates in the order of increasing severity are achieved by quenching from elevated temperatures as follows: furnace cooling, air cooling, oil quenching, liquid salts, water quenching, and brine. If these cooling curves are superimposed on the TTT diagram, the end product structure and the time required to complete the transformation may be found.

In Figure 1 the area on the left of the transformation curve represents the austenite region. Austenite is stable at temperatures above LCT but unstable below LCT. Left curve indicates the start of a transformation and right curve represents the finish of a transformation. The area between the two curves indicates the transformation of austenite to different types of crystal structures. (Austenite to pearlite, austenite to martensite, austenite to bainite transformation.)

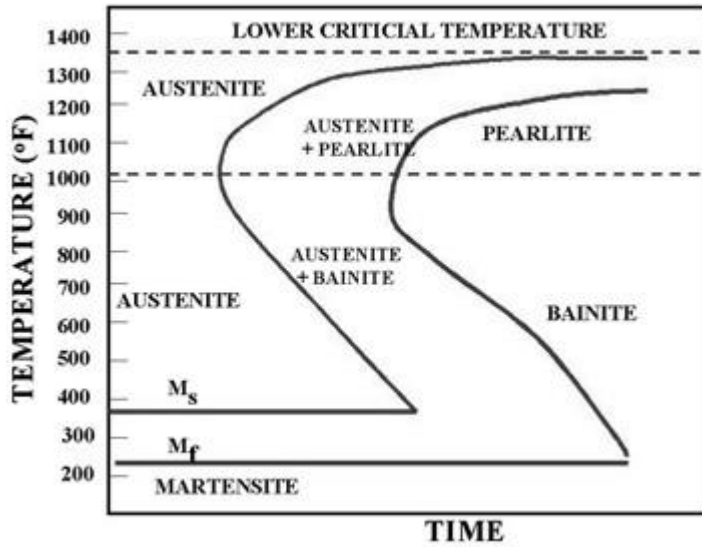

Figure 2.6 TTT Diagram

Figure 2 represents the upper half of the TTT diagram. As indicated in Figure 2, when austenite is cooled to temperatures below LCT, it transforms to other crystal structures due to its unstable nature. A specific cooling rate may be chosen so that the transformation of austenite can be 50 %, 100 % etc. If the cooling rate is very slow such as annealing process, the cooling curve passes through the entire transformation area and the end product of this the cooling process becomes 100% Pearlite. In other words, when slow cooling is applied, all the Austenite will transform to Pearlite. If the cooling curve passes through the middle of the transformation area, the end product is 50 % Austenite and 50% Pearlite, which means that at certain cooling rates we can retain part of the Austenite, without transforming it into Pearlite

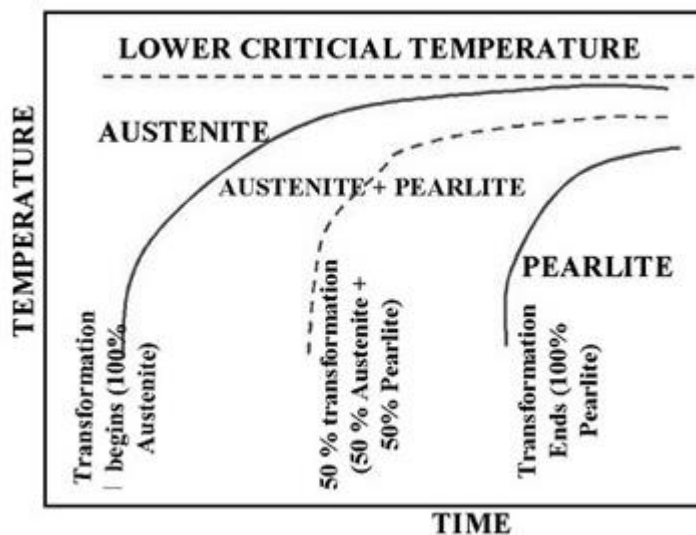

Figure 2.7 Upper half of TTT Diagram(Austenite-Pearlite Transformation Area)

Figure 2.7 indicates the types of transformation that can be found at higher cooling rates. If a cooling rate is very high, the cooling curve will remain on the left hand side of the Transformation Start curve. In this case all Austenite will transform to Martensite. If there is no interruption in cooling the end product will be martensite.

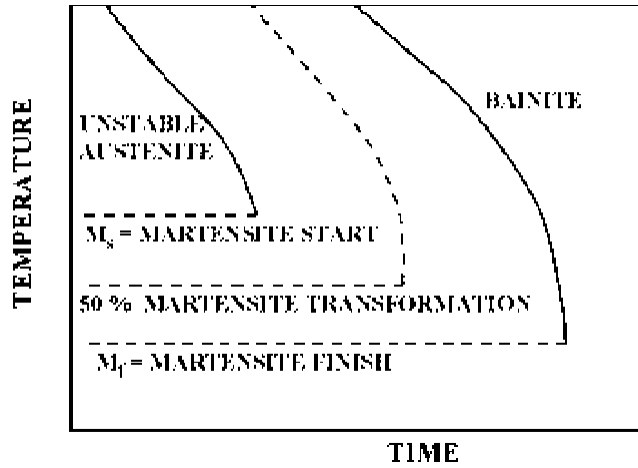

Figure 2.8 Lower half of TTT Diagram (Austenite-Martensite and Bainite Transformation Areas)

In Figure 2.9 the cooling rates A and B indicate two rapid cooling processes. In this case curve A will cause a higher distortion and a higher internal stresses than the cooling rate B. The end product of both cooling rates will be martensite. Cooling rate B is also known as the Critical Cooling Rate, which is represented by a cooling curve that is tangent to the nose of the TTT diagram. Critical Cooling Rate is defined as the lowest cooling rate which produces 100% Martensite while minimizing the internal stresses and distortions.

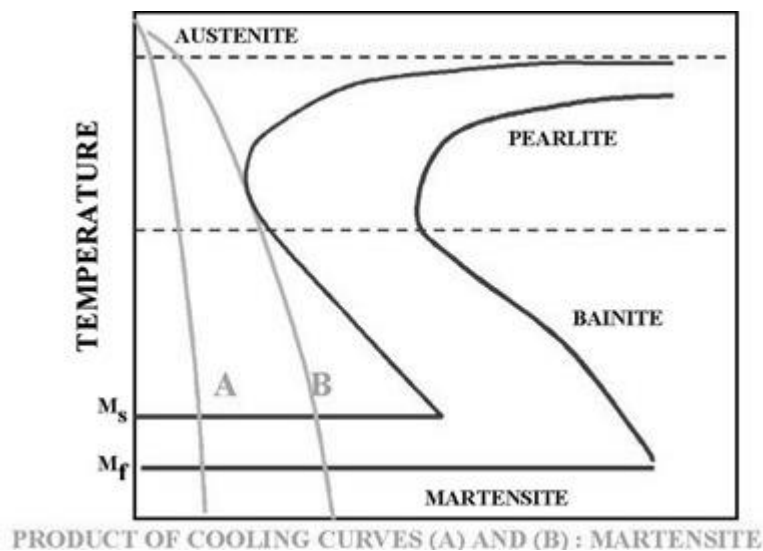

Figure 2.9. Rapid Quench

In Figure 2.10, a rapid quenching process is interrupted (horizontal line represents the interruption) by immersing the material in a molten salt bath and soaking at a constant temperature followed by another cooling process that passes through Bainite region of

TTT diagram. The end product is Bainite, which is not as hard as Martensite. As a result of cooling rate D; more dimensional stability, less distortion and less internal stresses are created.

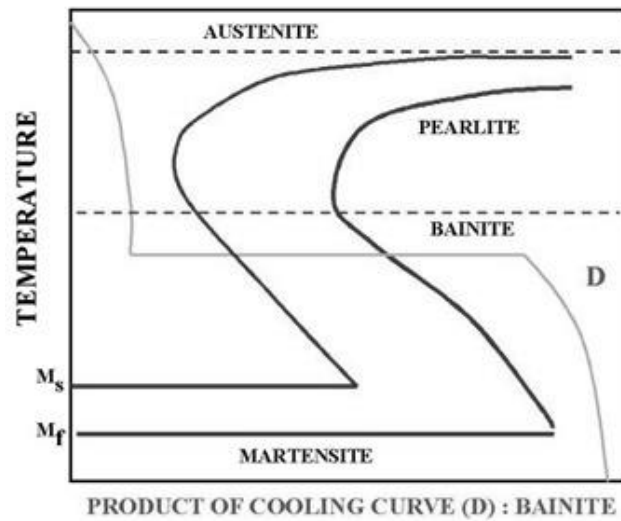

Figure 2.10 Interrupted Quench 35

In Figure 2.11 cooling curve C represents a slow cooling process, such as furnace cooling. An example for this type of cooling is annealing process where all the Austenite is allowed to transform to Pearlite as a result of slow cooling.

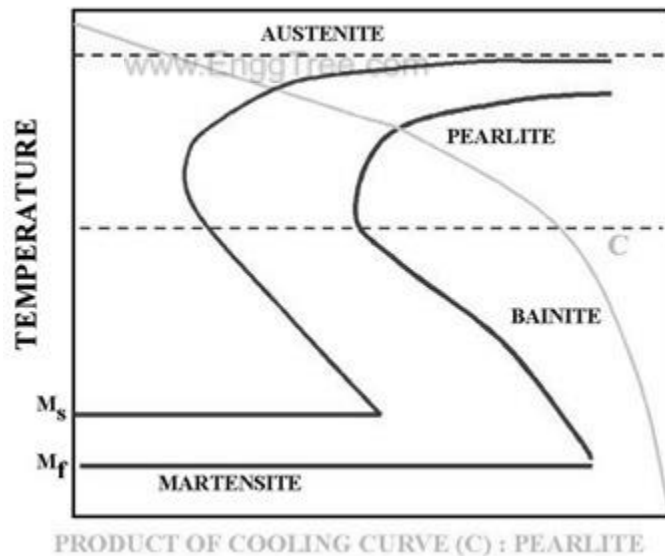

Figure 2.11 Slow cooling process (Annealing)

Sometimes the cooling curve may pass through the middle of the Austenite-Pearlite transformation zone. In Figure 2.12, cooling curve E indicates a cooling rate which is not high enough to produce 100% martensite. This can be observed easily by looking at the TTT diagram. Since the cooling curve E is not tangent to the nose of the transformation diagram, austenite is transformed to 50% Pearlite (curve E is tangent to 50% curve). Since curve E leaves the transformation diagram at the Martensite zone, the remaining 50 % of the Austenite will be transformed to Martensite.



Figure 2.14 Austenite



Figure 2.15 Pearlite



Figure 2.16 Martensite

Figure 2.17 Bainite

### Hardening and Tempering

Steels can be heat treated to high hardness and strength levels. The reasons for doing this are obvious. Structural components subjected to high operating stress need the high strength of a hardened structure. Similarly, tools such as dies, knives, cutting devices, and forming devices need a hardened structure to resist wear and deformation.

As-quenched hardened steels are so brittle that even slight impacts may cause fracture. Tempering is a heat treatment that reduces the brittleness of a steel without significantly lowering its hardness and strength. All hardened steels must be tempered before use.

### Tempering Austempering Martempering

www.EnggTree.com

- (1) Conventional Heat, Quench and Temper process
- (2) Martempering
- (3) Austempering

### Conventional Heat, Quench and Temper Process

In this process, Austenite is transformed to Martensite as a result of rapid quench from furnace to room temperature. Then, martensite is heated to a temperature which gives the desired hardness. One serious drawback is the possibility of distorting and cracking the metal as a result of severe quenching required to form Martensite without transforming any of the austenite to pearlite. During quenching process, the outer area is cooled quicker than the center. Thinner parts are cooled faster than parts with greater cross-sectional areas. What this means is that transformations of the Austenite are proceeding at different rates. As the metal cools, it also contracts and its microstructure occupies less volume. Extreme variations in size of metal parts complicate the work of the heat treated and should be avoided in the designing of metal parts. This means there is a limit to the overall size of parts that can be subjected to such thermal processing. Figure 1 shows the conventional hardening, tempering process.

## CONVENTIONAL QUENCHING AND TEMPERING

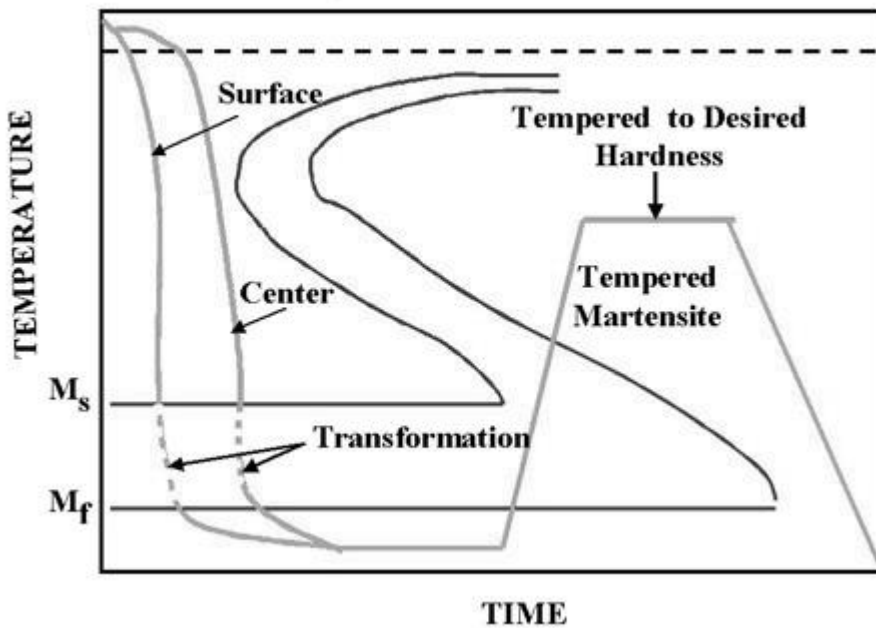

Figure 2.18 Conventional quenching and tempering process.

### Martempering (Marquenching)

To overcome the restrictions of conventional quenching and tempering, Martempering process can be used. Martempering or marquenching permits the transformation of Austenite to Martensite to take place at the same time throughout the structure of the metal part. This is shown in Figure 2.19. By using interrupted quench, the cooling is stopped at a point above the martensite transformation region to allow sufficient time for the center to cool to the same temperature as the surface. Then cooling is continued through the martensite region, followed by the usual tempering.

## MARTEMPERING

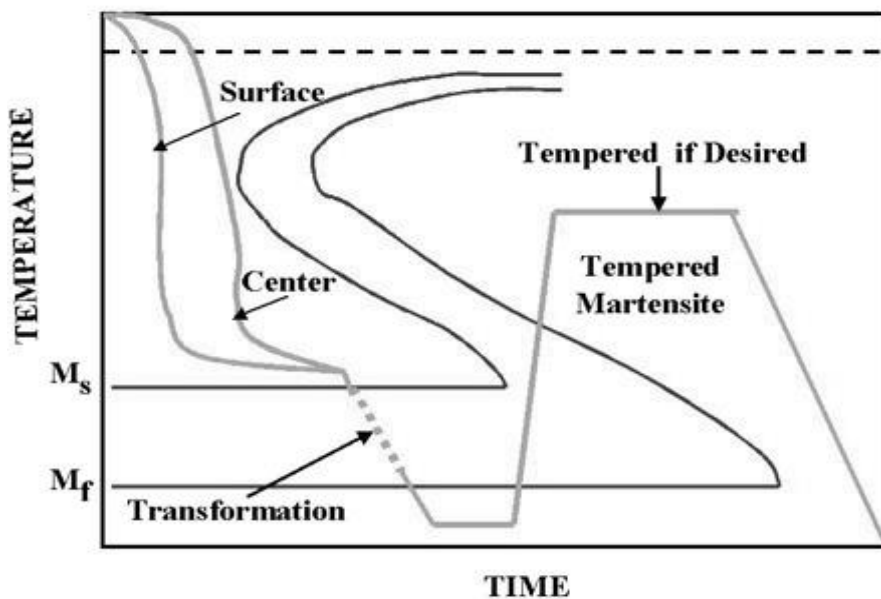

Figure 2.19 Martempering process.

## Austempering

This is the second method that can be used to overcome the restrictions of conventional quench and tempering. The quench is interrupted at a higher temperature than for Martempering to allow the metal at the center of the part to reach the same temperature as the surface. By maintaining that temperature, both the center and the surface are allowed to transform to Bainite and are then cooled to room temperature.

Advantages of Austempering:

1. Less distortion and cracking than martempering,
2. No need for final tempering (less time consuming and more energy efficient)
3. Improvement of toughness (impact resistance is higher than the conventional quench and tempering)
4. Improved ductility

Limitations of Austempering

Austempering can be applied to parts where the transformation to pearlite can be avoided. This means that the section must be cooled fast enough to avoid the formation of pearlite. Thin sections can be cooled faster than the bulky sections. Most industrial applications of austempering have been limited to sections less than 1/2 in. thick. The thickness can be increased by the use of alloy steels, but then the time for completion of transformation to bainite may become excessive.

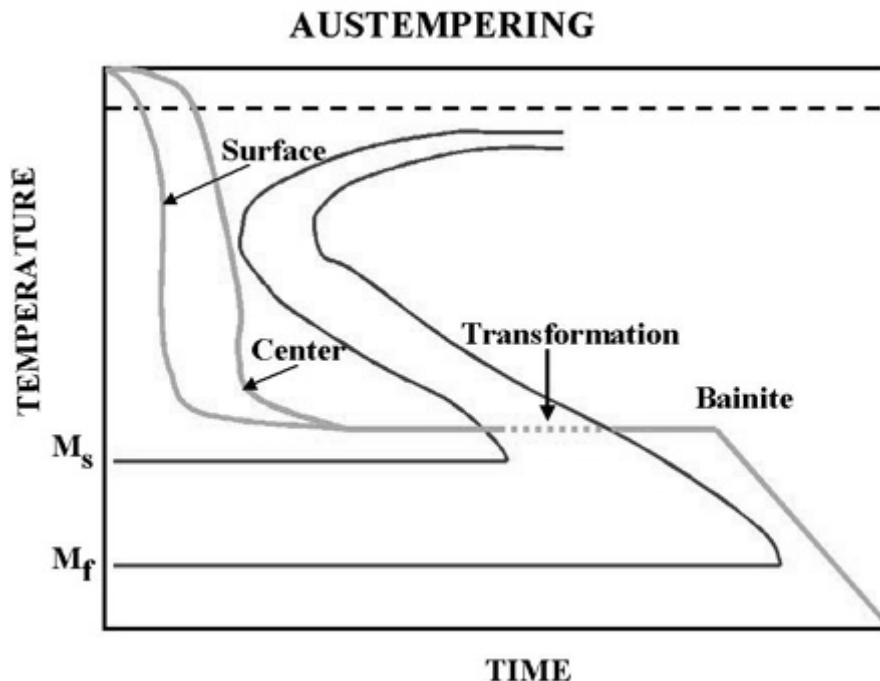

Figure 2.20 Austempering process.



In Austempering process, the end product is 100% bainite. It is accomplished by first heating the part to the proper austenitizing temperature followed by cooling rapidly in a salt bath which is maintained between 400 and 800 °F. The part is left in the bath until the transformation to bainite is complete. The steel is caused to go directly from austenite to bainite. The austemper process offers benefits over the more conventional oil quench and temper method of heat treating springs and stampings that requires the uppermost in distortion control. The process consists of quenching the part from the proper austenitizing temperature directly into a liquid salt bath at a temperature between 590 to 710 degrees Fahrenheit. The part is held at this quench temperature for a recommended time to transform the Austenite into Bainite. The part is then removed from the salt quench and air cooled to room temperature.

Advantages of Austempering:

- Less Distortion
- Greater Ductility
- Parts are plater friendly due to the clean surface from the salt quench
- Uniform and consistent Hardness
- Tougher and More Wear Resistant
- Higher Impact and Fatigue Strengths
- Resistance to Hydrogen Embrittlement

### **Hardenability and Jominy End Quench Test**

The influence of alloy composition on the ability of a steel alloy to transform to martensite for a particular quenching treatment is related to a parameter called hardenability. For every different steel alloy there is a specific relationship between the mechanical properties and the cooling rate. Hardenability is used to describe the ability of an alloy to be hardened by the formation of martensite as a result of a given heat treatment. One standard procedure that is widely utilized to determine hardenability is the Jominy end quench test. The heating and cooling treatment of the steel specimens have a great effect on the phase of the microstructure of the steel specimen. The addition of alloys or coarsening of the austenitic grain structure increase the hardenability of steel. Any steel that has low critical cooling rate will harden deeper than one that has a high cooling rate of quenching. The size of the part that is being quenched has a direct effect upon the hardenability of the material. The objective of the experiment is to take readings in the Rockwell C scale along the flat surface of the Jominy specimen and to plot Hardness versus distance from quenched end.

Equipment: Electric Furnace, Jominy End Quench Test Fixture, Jominy Specimens (Made as per ASTM standard), Rockwell Hardness Testing Machine.

Procedure:

1. Preheat the furnace to 1700 °F.
2. Place the Jominy specimen in the furnace and soak for one hour.
3. Turn the water on at the Jominy sink. Adjust the free water column to about 2.5 in. Swivel the baffle plate to block the water column so that there is no contact between water and the test specimen when the test specimen is initially placed on the fixture.
4. Remove the Jominy specimen from the furnace and place it in the fixture as shown in Figure 2.21. Swivel the baffle out of position so that the water impinges on the

bottom of the specimen without wetting the sides of the specimen. Leave water running for about 15 minutes.

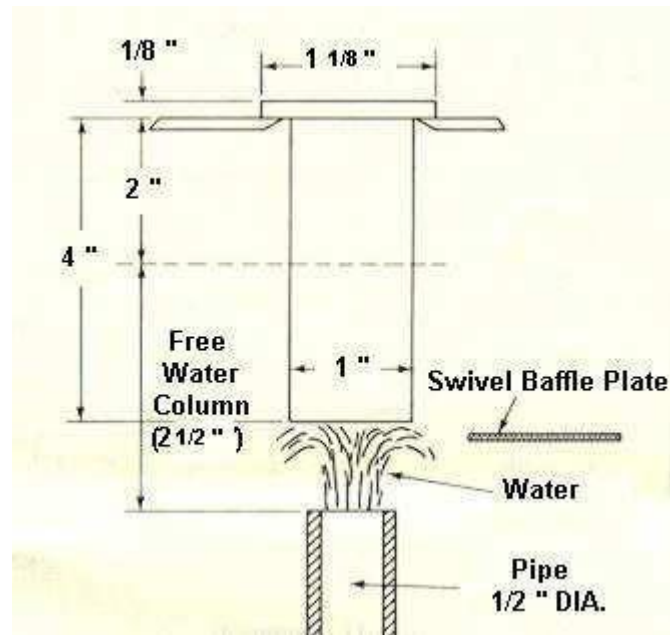

Figure 2.21. Jominy end quench fixture

5. Remove the Jominy specimen from the fixture and grind a flat on the side of the specimen.

[www.EnggTree.com](http://www.EnggTree.com)

6. Mark points on the ground surface at an interval of  $1/16$  in. up to 2 in. distance from the quenched end as shown in Figure 2.22.

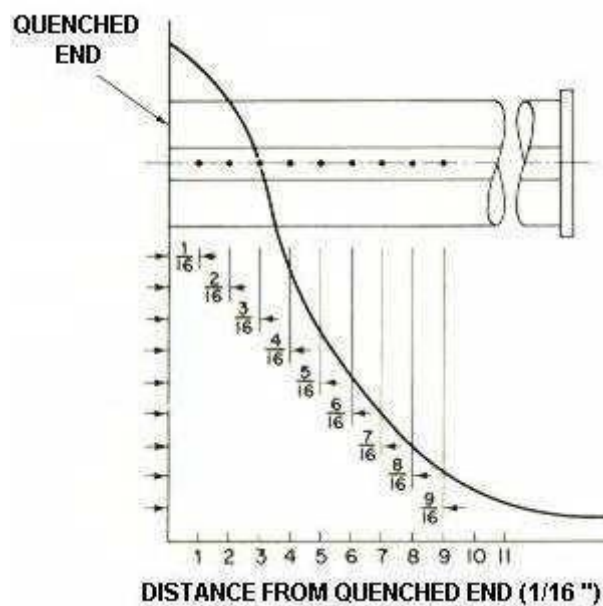

Figure 2.22

7. Take readings at an interval of 1/16 in. by measuring the Rockwell C hardness at each point marked in the previous step.
8. Plot the data for Rockwell Hardness versus Distance from quenched end as shown in Figure 2.23.

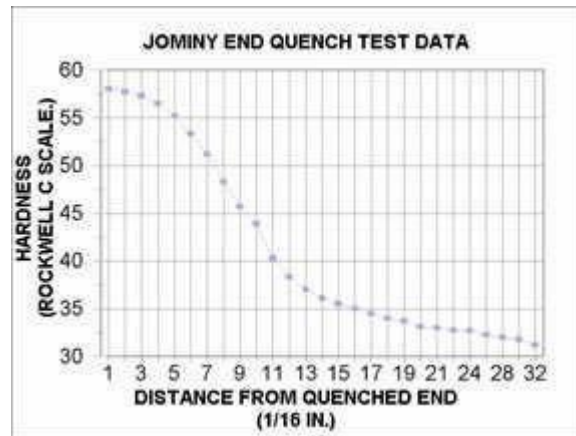

Figure 2.23

Determining the Hardenability of a Material:

In the Jominy test the quenching medium is eliminated from consideration by standardizing the effect of the quenching medium on a steel sample regardless of the medium. This is designated by the ratio of the heat transfer factor  $F$  to the thermal conductivity  $K$  of the material. This ratio is called  $H$ -factor which indicates the severity of a cooling rate.

$$H = F/K$$

$F$  = Heat transfer factor

$K$  = Thermal conductivity

## CASE HARDENING

Surface hardening is a process which includes a wide variety of techniques is used to improve the wear resistance of parts without affecting the softer, tough interior of the part. This combination of hard surface and resistance and breakage upon impact is useful in parts such as a cam or ring gear that must have a very hard surface to resist wear, along with a tough interior to resist the impact that occurs during operation. Further, the surface hardening of steels has an advantage over through hardening because less expensive low-carbon and medium-carbon steels can be surface hardened without the problems of distortion and cracking associated with the through hardening of thick sections.

Casehardening produces a hard wear resistant surface or case over a strong, tough core. Casehardening is ideal for parts which require a wear resistant surface and at the same time, must be tough enough internally to withstand the applied loads. The steels best suited to casehardening are the low carbon and low alloy steels. If high carbon steel is casehardened, the hardness penetrates the core and causes brittleness. In casehardening, the surface of the metal is changed chemically by introducing a high carbide or nitride content. The core is chemically unaffected. When heat treated, the surface responds to hardening while the core toughens. The common forms of

casehardening are carburizing, cyaniding and nitriding. The surface hardening by diffusion involves the chemical modification of a surface. The basic process used is thermo-chemical because some heat is needed to enhance the diffusion of hardening species into the surface and subsurface regions of part. The depth of diffusion exhibits time- temperature dependence such that:

$$\text{Case depth} \approx K \sqrt{\text{Time}}$$

where the diffusivity constant,  $K$ , depends on temperature, the chemical composition of the steel, and the concentration gradient of a given hardening species. In terms of temperature, the diffusivity constant increases exponentially as a function of absolute temperature. Concentration gradients depend on the surface kinetics and reactions of a particular process.

Methods of hardening by diffusion include several variations of hardening species (such as carbon, nitrogen, or boron) and of the process method used to handle and transport the hardening species to the surface of the part. Process methods for exposure involve the handling of hardening species in forms such as gas, liquid, or ions. These process variations naturally produce differences in typical case depth and hardness. Factors influencing the suitability of a particular diffusion method include the type of steel. It is also important to distinguish between total case depth and effective case depth. The effective case depth is typically about two-thirds to three-fourths the total case depth. The required effective depth must be specified so that the heat treatment can process the parts for the correct time at the proper temperature.

## 2.10 Carburizing

Carburizing is a casehardening process in which carbon is added to the surface of low carbon steel. Thus, carburized steel has a high carbon surface and a low carbon interior. When the carburized steel is heat treated, the case is hardened while the core remains soft and tough. Carburizing is the addition of carbon to the surface of low-carbon steels at temperatures generally between 850 and 950°C (1560 and 1740°F), at which austenite, with its high solubility for carbon, is the stable crystal structure. Hardening is accomplished when the high-carbon surface layer is quenched to form martensite so that a high-carbon martensitic case with good wear and fatigue resistance is superimposed on a tough, low-carbon steel core. Case hardness of carburized steels is primarily a function of carbon content. When the carbon content of the steel exceeds about 0.50% additional carbon has no effect on hardness but does enhance hardenability. Carbon in excess of 0.50% may not be dissolved, which would thus require temperatures high enough to ensure carbon-austenite solid solution.

Case depth of carburized steel is a function of carburizing time and the available carbon potential at the surface. The variation of case depth with carburizing time is shown in Figure-2.28. When prolonged carburizing times are used for deep case depths, a high carbon potential produces a high surface-carbon content, which may thus result in excessive retained austenite or free carbides. These two micro structural elements both have adverse effects on the distribution of residual stress in the case-hardened part. Consequently, a high carbon potential may be suitable for short carburizing times but not for prolonged carburizing.

Carburizing steels for case hardening usually have base-carbon contents of about 0.2%, with the carbon content of the carburized layer generally being controlled at between

0.8 and 1% C. However, surface carbon is often limited to 0.9% because too high a carbon content can result in retained austenite and brittle martensite.

Most steels that are carburized are killed steels (deoxidized by the addition of aluminum), which maintain fine grain sizes to temperatures of about 1040°C. Steels made to coarse grain practices can be carburized if a double quench provides grain refinement. Double quenching usually consists of a direct quench and then a re-quench from a lower temperature.

In another method of carburizing, called "gas carburizing," a material rich in carbon is introduced into the furnace atmosphere. The carburizing atmosphere is produced by the use of various gases or by the burning of oil, wood, or other materials. When the steel parts are heated in this atmosphere, carbon monoxide combines with the gamma iron to produce practically the same results as those described under the pack carburizing process.

A third method of carburizing is that of "liquid carburizing." In this method the steel is placed in a molten salt bath that contains the chemicals required to produce a case comparable with one resulting from pack or gas carburizing.

Alloy steels with low carbon content as well as low carbon steels may be carburized by either of the three processes. However, some alloys, such as nickel, tend to retard the absorption of carbon. As a result, the time required to produce a given thickness of case varies with the composition of the metal.

Quenching:

www.EnggTree.com

All of the carburizing processes (pack, gas, liquid) require quenching from the carburizing temperature or a lower temperature or reheating and quenching. Parts are then tempered to the desired hardness.

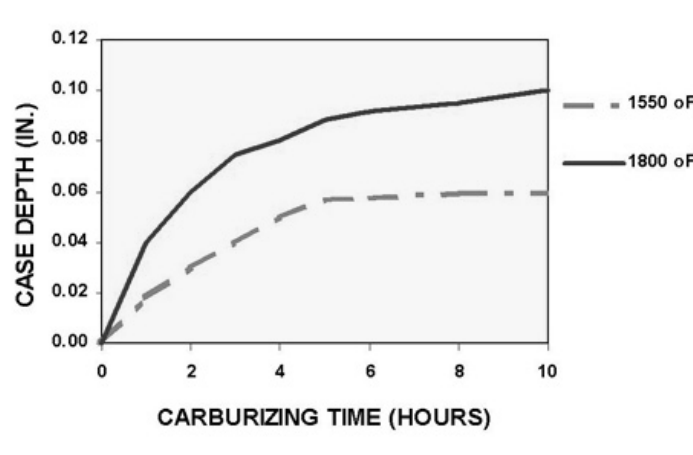

Figure 2.28 Case depth vs. Carburizing time.

### Pack Carburizing

In this process, the part that is to be carburized is packed in a steel container so that it is completely surrounded by granules of charcoal. The charcoal is treated with an activating chemical such as Barium Carbonate ( $\text{BaCO}_3$ ) that promotes the formation of

Carbon Dioxide ( $\text{CO}_2$ ). This gas in turn reacts with the excess carbon in the charcoal to produce carbon monoxide;  $\text{CO}$ . Carbon Monoxide reacts with the low-carbon steel surface to form atomic carbon which diffuses into the steel. Carbon Monoxide supplies the carbon gradient that is necessary for diffusion. The carburizing process does not harden the steel. It only increases the carbon content to some predetermined depth below the surface to a sufficient level to allow subsequent quench hardening.

Carbon Monoxide reaction:  $\text{CO}_2 + \text{C} \rightarrow 2 \text{CO}$

Reaction of Cementite to Carbon Monoxide:  $2 \text{CO} + 3 \text{Fe} \rightarrow \text{Fe}_3\text{C} + \text{CO}_2$

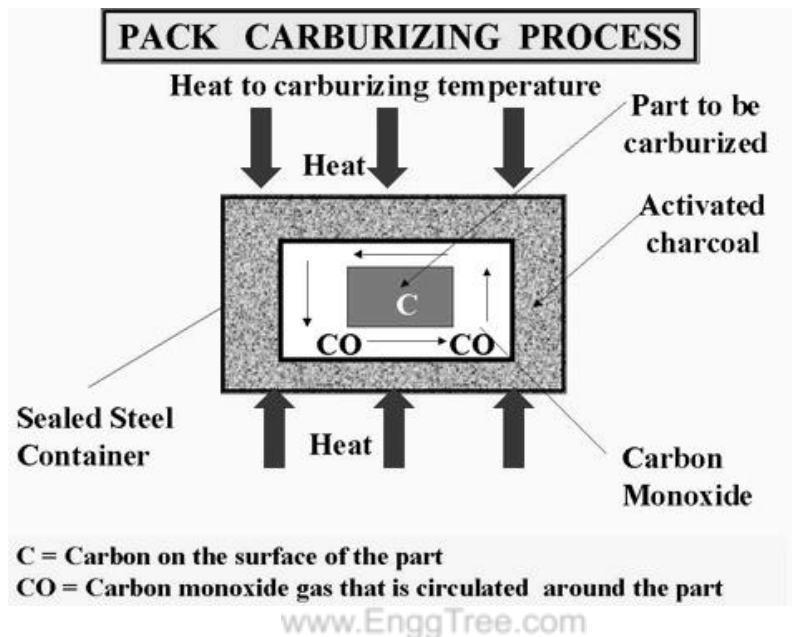

Figure 2.29 Pack carburizing process

#### Quenching Process:

It is difficult to quench the part immediately, as the sealed pack has to be opened and the part must be removed from the pack. One technique that is used often is to slow cool the entire pack and subsequently harden and temper the part after it is removed from the sealed pack.

#### Depth of Hardening:

There is no technical limit to the depth of hardening with carburizing techniques, but it is not common to carburize to depths in excess of 0.050 in.

Carburizing Time: 4 to 10 hours

#### Gas Carburizing

Can be done with any carbonaceous gas, such as methane, ethane, propane, or natural gas. Most carburizing gases are flammable and controls are needed to keep carburizing gas at 1700 °F from contacting air (oxygen). The advantage of this process over pack carburizing is an improved ability to quench from the carburizing temperature. Conveyor hearth furnaces make quenching in a controlled atmosphere possible. In gas carburizing, the parts are surrounded by a carbon-bearing atmosphere that can be continuously replenished so that a high carbon potential can be maintained.

While the rate of carburizing is substantially increased in the gaseous atmosphere, the method requires the use of a multicomponent atmosphere whose composition must be very closely controlled to avoid deleterious side effects, for example, surface and grain-boundary oxides. In addition, a separate piece of equipment is required to generate the atmosphere and control its composition. Despite this increased complexity, gas carburizing has become the most effective and widely used method for carburizing steel parts in large quantities. In efforts required to simplify the atmosphere, carburizing in an oxygen-free environment at very low pressure (vacuum carburizing) has been explored and developed into a viable and important alternative. Although the furnace enclosure in some respects becomes more complex, the atmosphere is greatly simplified. A single-component atmosphere consisting solely of a simple gaseous hydrocarbon, for example methane, may be used. Furthermore, because the parts are heated in an oxygen-free environment, the carburizing temperature may be increased substantially without the risk of surface or grain-boundary oxidation. The higher temperature permitted increases not only the solid solubility of carbon in the austenite but also its rate of diffusion, so that the time required to achieve the case depth desired is reduced.

Although vacuum carburizing overcomes some of the complexities of gas carburizing, it introduces a serious new problem that must be addressed. Because vacuum carburizing is conducted at very low pressures, and the rate of flow of the carburizing gas into the furnace is very low, the carbon potential of the gas in deep recesses and blind holes is quickly depleted. Unless this gas is replenished, a great nonuniformity in case depth over the surface of the part is likely to occur. If, in an effort to overcome this problem, the gas pressure is increased significantly, another problem arises, that of free-carbon formation, or sooting.

[www.EnggTree.com](http://www.EnggTree.com)

### Liquid Carburizing

Can be performed in internally or externally heated molten salt pots. Carburizing salt contains cyanide compounds such as sodium cyanide (NaCN). Cycle times for liquid cyaniding is much shorter (1 to 4 hours) than gas and pack carburizing processes. Disadvantage is the disposal of salt. (Environmental problems) and cost (safe disposal is very expensive).

### Nitriding - Cyaniding

Nitriding is unlike other casehardening processes in that, before nitriding, the part is heat treated to produce definite physical properties. Thus, parts are hardened and tempered before being nitrided. Most steels can be nitrided, but special alloys are required for best results. These special alloys contain aluminum as one of the alloying elements and are called "nitralloys."

Principal reasons for nitriding are:

- To obtain high surface hardness
- To increase wear resistance and antigalling properties
- To improve fatigue life
- To improve corrosion resistance
- To obtain a surface that is resistant to the softening effect of heat at temperatures up to the nitriding temperature.

In nitriding, the part is placed in a special nitriding furnace and heated to a temperature of approximately 1,000°F. With the part at this temperature, ammonia gas

is circulated within the specially constructed furnace chamber. The high temperature cracks the ammonia gas into nitrogen and hydrogen. The ammonia which does not break down is caught in a water trap below the regions of the other two gases. The nitrogen reacts with the iron to form nitride. The iron nitride is dispersed in minute particles at the surface and works inward. The depth of penetration depends on the length of the treatment. In nitriding, soaking periods as long as 72 hours are frequently required to produce the desired thickness of case. Nitriding can be accomplished with a minimum of distortion, because of the low temperature at which parts are casehardened and because no quenching is required after exposure to the ammonia gas.

In this process, nitrogen is diffused into the surface of the steel being treated. The reaction of nitrogen with the steel causes the formation of very hard iron and alloy nitrogen compounds. The resulting nitride case is harder than tool steels or carburized steels. The advantage of this process is that hardness is achieved without the oil, water or air quench. As an added advantage, hardening is accomplished in a nitrogen atmosphere that prevents scaling and discoloration. Nitriding temperature is below the lower critical temperature of the steel and it is set between 925 °F and 1050 °F. The nitrogen source is usually Ammonia (NH<sub>3</sub>). At the nitriding temperature the ammonia dissociates into Nitrogen and Hydrogen.

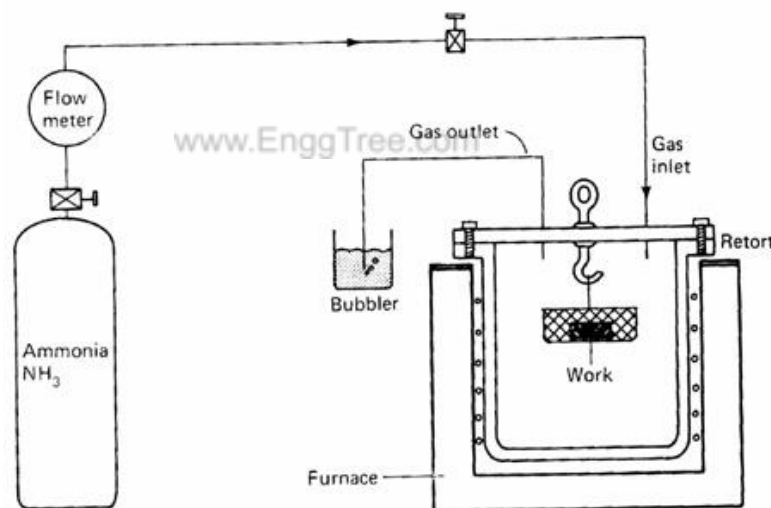
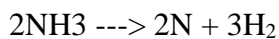

Figure 2.30 Nitriding process

The nitrogen diffuses into the steel and hydrogen is exhausted. A typical nitriding setup is illustrated in Figure 2.30.



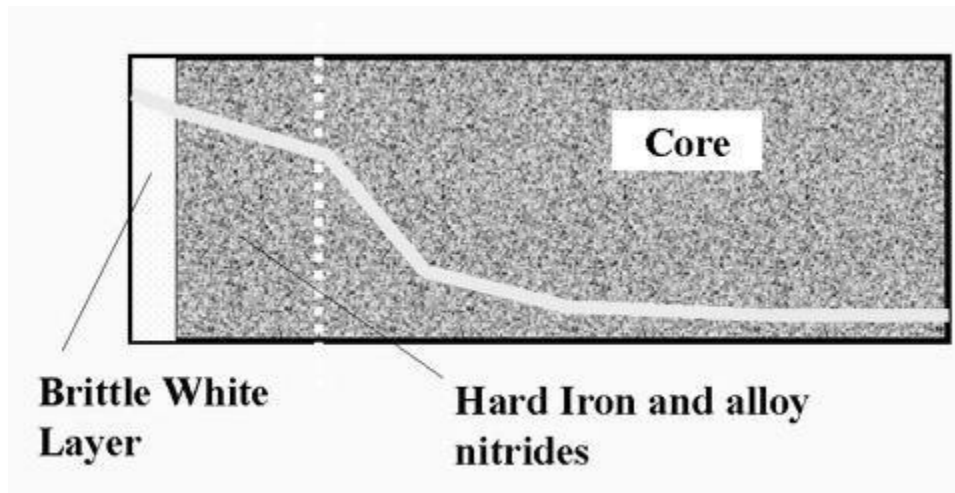

Figure 2.31

The white layer shown in Figure 4 has a detrimental effect on the fatigue life of nitrided parts, and it is normally removed from parts subjected to severe service. Two stage gas-nitriding processes can be used to prevent the formation of white layer. White layer thickness may vary between 0.0003 and 0.002 in. which depends on nitriding time. The most commonly nitrided steels are chromium- molybdenum alloy steels and Nitralloys. Surface hardness of 55 HRC to 70 HRC can be achieved with case depths varying from 0.005 in to 0.020 in. Nitrided steels are very hard and grinding operations should not be performed after nitriding. White layer is removed by lapping.

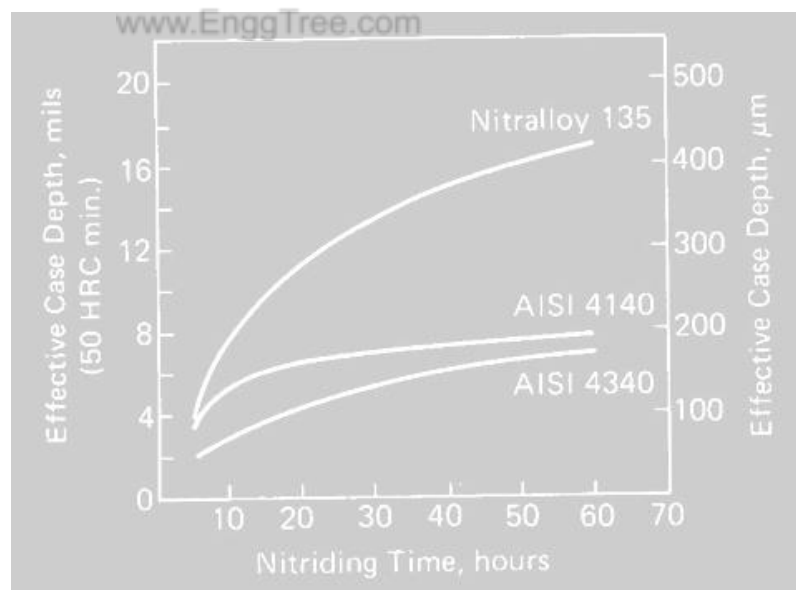

Figure 2.31 Nitriding time for various types of alloy steels

### CARBURISING Vs. NITRIDING

Gas nitriding is emerging as the significant surface hardening process for today's and future industry, constituting a viable alternative to the well-established carburizing process. Most gears, shafts, hubs, pins and other parts are carburized in mass production

to various case depths with accurate carbon potential control. Yet, carburizing is handicapped by several disadvantages. Below table compares certain important features of the two processes.

FEATURE COMPARED	CARBURISING	NITRIDING
Material compatibility	Limited selection of steel types	Wide variety of steel grades, including austenitic stainless, maraging and precipitation – hardening range
Typical treatment temperature	850 – 950°C	460-600°C
Accompanying heat treatment	Requires hardening and tempering (optionally: sub-zero treatment)	No additional treatment required
Finish Machining	Often requires costly grinding	In most cases, does NOT require finish grinding
Distortion	May be substantial	Due to lower heat treatment temperature and absence of transformation in bulk material, distortion minimum to nil
Surface cleanliness	In most cases requires washing to remove quenching oil	After nitriding, surface ready for shipping
Surface hardness	60 – 65 HRC	Depending on steel grade, may reach 70 HRC
Corrosion resistance	High carbon concentrations are conducive to stress corrosion cracking	Compound layer enhances corrosion resistance (with the exception of stainless steels)

### Carbonitriding:

Carbonitriding is a modified form of gas carburizing, rather than a form of nitriding. The modification consists of introducing ammonia into the gas carburizing atmosphere to add nitrogen to the carburized case as it is being produced. Nascent nitrogen forms at the work surface by the dissociation of ammonia in the furnace atmosphere; the nitrogen diffuses into the steel simultaneously with carbon. Typically, carbonitriding is

carried out at a lower temperature and for a shorter time than is gas carburizing, producing a shallower case than is usual in production carburizing.

Carbonitriding is used primarily to impart a hard, wear-resistant case, generally from 0.075 to 0.75 mm (0.003 to 0.030 in.) deep. A carbonitrided case has better hardenability than a carburized case. Consequently, by carbonitriding and quenching, a hardened case can be produced at less expense within the case-depth range indicated, using either carbon or low-alloy steel. Full hardness with less distortion can be achieved with oil quenching, or, in some instances, even gas quenching, employing a protective atmosphere as the quenching medium.

Steels commonly carbonitrided include those in the AISI 1000, 1100, 1200, 1300, 1500, 4000, 4100, 4600, 5100, 6100, 8600, and 8700 series, with carbon contents up to about 0.25%. Also, many steels in these same series with a carbon range of 0.30 to 0.50% are carbonitrided to case depths up to about 0.3 mm (0.01 in.) when a combination of a reasonably tough, through-hardened core and a hard, long-wearing surface is required (shafts and transmission gears are typical examples). Steels such as 4140, 5130, 5140, 8640, and 4340 for applications like heavy-duty gearing are treated by this method at 845°C (1550°F).

Often, carburizing and carbonitriding are used together to achieve much deeper case depths and better engineering performance for parts than could be obtained using only the carbonitriding process. This process is applicable particularly with steels with low case hardenability, that is, the 1000, 1100, and 1200 series steels. The process generally consists of carburizing at 900 to 955°C (1650 to 1750°F) to give the desired total case depth (up to 2.5 mm. or 0.100 in.), followed by carbonitriding for 2 to 6 h in the temperature range of 815 to 900°C (1500 to 1650°F) to add the desired carbonitrided case depth. The subject parts can then be oil quenched to obtain a deeper effective and thus harder case than would have resulted from the carburizing process alone. The addition of the carbonitrided surface increases the case residual compressive stress level and thus improves contact fatigue resistance as well as increasing the case strength gradient.

When the carburizing/carbonitriding processes are used together, the effective case depth (50 HRC) to total case depth ratio may vary from about 0.35 to 0.75 depending on the case hardenability, core hardenability, section size, and quenchant used. The fundamental problem in controlling carbonitriding processes is that the rate of nitrogen pick-up depends on the free ammonia content of the furnace atmosphere and not the percentage of ammonia in the inlet gas. Unfortunately, no state-of-the-art sensor for monitoring the free ammonia content of the furnace atmosphere has yet been developed. Case Composition. The composition of a carbonitrided case depends on the type of steel and on the process variables of temperature, time, and atmosphere composition. In terms of steel type, the case depth achieved during a given carbonitriding process will be lower in steels containing higher amounts of strong nitride formers such as aluminum or titanium. In terms of process variables, the higher the carbonitriding temperature, the less effective is the ammonia addition to the atmosphere as a nitrogen source, because the rate of spontaneous decomposition of ammonia to molecular nitrogen and hydrogen increases as the temperature is raised.

At a given temperature, the fraction of the ammonia addition that spontaneously

decomposes is dependent on the residence time of the atmosphere in the furnace: the higher the total flow of atmosphere gases, the lower the fraction of the ammonia addition that decomposes to nitrogen and hydrogen. The addition of ammonia to a carburizing atmosphere has the effect of dilution by the following reaction:

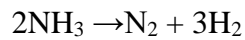

Dilution with nitrogen and hydrogen affects measurements of oxygen potential in a similar manner; the carbon potential possible with given oxygen potential is higher in a carburizing atmosphere than in a carbonitriding atmosphere. Water vapor content, however, is much less affected by this dilution. Thus, the amount of dilution and its resulting effect on the atmosphere composition depends on the processing temperature, the amount of ammonia introduced, and the ratio of the total atmosphere gas flow rate to the volume of the furnace.

Depth of Case. Preferred case depth is governed by service application and by core hardness. Case depths of 0.025 to 0.075 mm (0.001 to 0.003 in.) are commonly applied to thin pans that require wear resistance under light loads. Case depths up to 0.75 mm (0.030 in.) may be applied to parts for resisting high compressive loads. Case depths of 0.63 to 0.75 mm (0.025 to 0.030 in.) may be applied to shafts and gears that are subjected to high tensile or compressive stresses caused by torsion, bending, or contact loads.

Medium-carbon steels with core hardness of 40 to 45 HRC normally require less case depth than steels with core hardness of 20 HRC or below. Low-alloy steels with medium-carbon content, such as those used in automotive transmission gears, are often assigned minimum case depths of 0.2 mm (0.008 in.).

Measurements of the case depths of carbonitrided parts may refer to effective case depth or total case depth, as with reporting case depths for carburized parts. For very thin cases, usually only the total case depth is specified. In general, it is easy to distinguish case and core microstructures in a carbonitrided piece, particularly when the case is thin and is produced at a low carbonitriding temperature; more difficulty is encountered in distinguishing case and core when high temperatures, deep cases, and medium-carbon or high-carbon steels are involved. Whether or not the core has a martensitic structure is also a contributing factor in case-depth measurements.

Hardenability of Case. One major advantage of carbonitriding is that the nitrogen absorbed during processing lowers the critical cooling rate of the steel. That is, the hardenability of the case is significantly greater when nitrogen is added by carbonitriding than when the same steel is only carburized. This permits the use of steels on which uniform case hardness ordinarily could not be obtained if they were only carburized and quenched. Where core properties are not important, carbonitriding permits the use of low-carbon steels, which cost less and may have better machinability or formability.

This process involves with the diffusion of both carbon and nitrogen into the steel surface. The process is performed in a gas atmosphere furnace using a carburizing gas such as propane or methane mixed with several percent (by volume) of ammonia. Methane or propane serve as the source of carbon, the ammonia serves as the source of nitrogen. Quenching is done in a gas which is not as severe as water quench. As a result

of less severe quench, there is less distortion on the material to be treated. A typical carbonitriding system is shown in the following slide. Case hardnesses of HRC 60 to 65 are achieved at the surface. (Not as high as nitrided surfaces.) Case depths of 0.003 to 0.030 in can be accomplished by carbonitriding. One of the advantages of this process is that it can be applied to plain carbon steels which give significant case depths. Carbonitriding gives less distortion than carburizing. Carbonitriding is performed at temperatures above the transformation temperature of the steels (1400 °F -to 1600 °F)

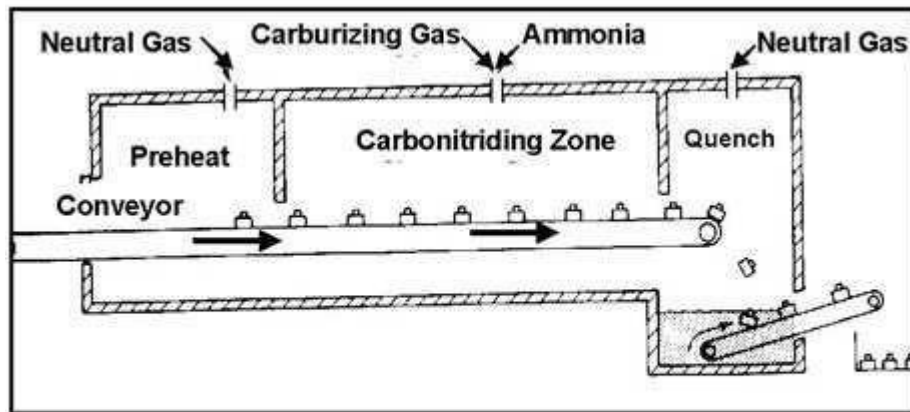

**Conveyor Hearth Carbonitriding**

Applications.

[www.EnggTree.com](http://www.EnggTree.com)

Although carbonitriding is a modified carburizing process, its applications are more restricted than those of carburizing. As has been stated previously, carbonitriding is largely limited to case depths of about 0.75 mm (0.03 in.) or less, while no such limitation applies to carburizing. Two reasons for this are: carbonitriding is generally done at temperatures of 870°C (1600°F) and below, whereas, because of the time factor involved, deeper cases are produced by processing at higher temperatures; and the nitrogen addition is less readily controlled than is the carbon addition, a condition that can lead to an excess of nitrogen, and, consequently, to high levels of retained austenite and case porosity when processing times are too long. The resistance of a carbonitrided surface to softening during tempering is markedly superior to that of a carburized surface. Other notable differences exist in terms of residual-stress pattern, metallurgical structure, fatigue and impact strength at specific hardness levels, and effects of alloy composition on case and core characteristics.

### **Flame Hardening:**

Flame hardening is the process of selective hardening with a combustible gas flame as the source of heat for austenitizing. (The material should have at least 0.40 % Carbon content to allow hardening.) Water quenching is applied as soon as the transformation temperature is reached. The heating media can be oxygen acetylene, propane, or any other combination of fuel gases that will allow reasonable heating rates. This procedure is applied to the gear teeth, shear blades, cams, ways on the lathes, etc. Flame hardening temperatures are around 1500°F. Up to HRC 65 hardness can be achieved. For best results the hardness depth is 3/16 inch.

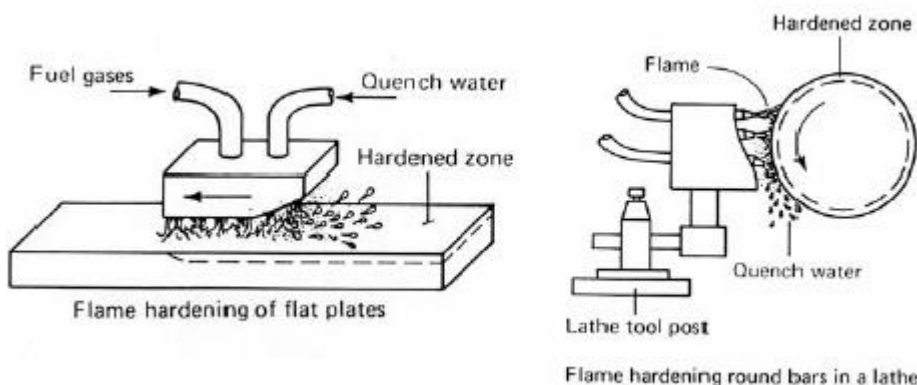

Figure 2.34 Flame hardening There are three methods of flame hardening are

- (1) SPOT Flame Hardening: Flame is directed to the spot that needs to be heated and hardened.
- (2) SPIN Flame Hardening: The workpiece is rotated while in contact with the flame
- (3) PROGRESSIVE Flame Hardening: The torch and the quenching medium move across the surface of the workpiece.

How to Select the Right Surface Hardening Method:

- (1) Carburizing is the best method for low carbon steels.
- (2) Nitriding is a lower distortion process than carburizing but it can be used for certain type of steels such as chromium-molybdenum alloy steels or Nitralloy-type steels.
- (3) Flame hardening is preferred for heavy cases or selective hardening of large machine components.
- (4) Induction hardening works best on parts small enough and suitable in shape to be compatible with the induction coil.
- (5) Electron beam and laser hardening are limited to the low alloy steels and plain carbon steels only. *Application Reference Chart*

PROCESS	APPLICATIONS
Carburizing	Gears, cams, shafts, piston pins, sprockets
Carbonitriding	Bolts, nuts gears
Gas Nitriding	Gears, shafts, sprockets, valves, and fuel injection
FNC	pump parts
Vacuum Harden	Clutch plates, gears, washers
Vacuum	Tool & Die

Carburize	Bearing races, rings & pinions and drive train components
-----------	---

### Induction Hardening:

In this process an electric current flow is induced in the work piece to produce a heating action. Every electrical conductor carrying a current has a magnetic field surrounding the conductor. Since the core wire is a dead-end circuit, the induced current cannot flow anyplace, so the net effect is heating of the wire. The induced current in the core conductor alternates at frequencies from 60 cycles per second (60 Hz) to millions of Hertz. The resistance to current flow causes very rapid heating of the core material. Heating occurs from the outside inward. Induction hardening process includes water quench after the heating process. The big advantage of this system is its speed and ability to confine heating on small parts. The major disadvantage is the cost.

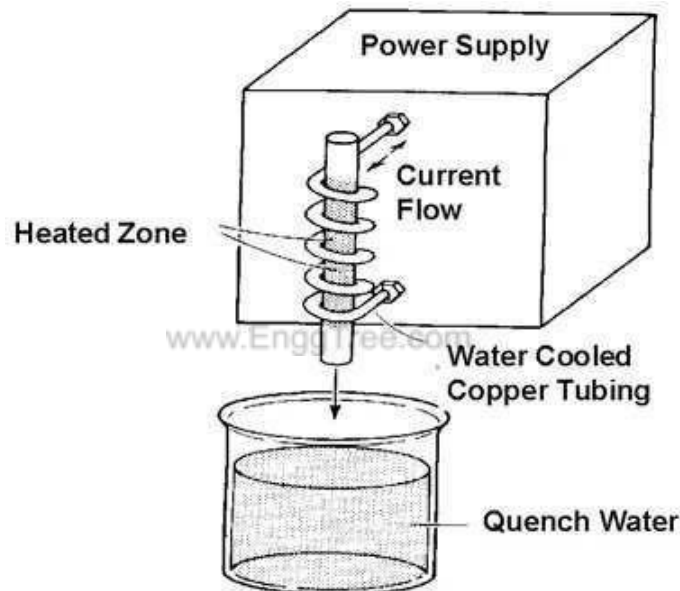

Figure 2.33. Induction hardening

### Vacuum and plasma hardening

#### Process details

1. evacuation of the furnace is started and vacuum level of better than  $1 \times 10^{-3}$  mbar is achieved.
2. heating of the furnace starts when the vacuum level of  $1.33 \times 10^{-1}$  mbar is reached..
3. Heating cycle Room Temperature |  $10^\circ\text{C}/\text{min}$   $650^\circ\text{C}$  -120 mts soaking at furnace temperature |  $10^\circ\text{C}/\text{min}$   $850^\circ\text{C}$ -120mts |  $5^\circ\text{C}/\text{min}$   $1000^\circ\text{C}$ -60mts |  $5^\circ\text{C}/\text{min}$   $1100^\circ\text{C}$ -60mts |  $1170^\circ\text{C}$ -30mts |  $5^\circ\text{C}/\text{min}$   $1250^\circ\text{C}$ -30min
4. Cooling cycle

### Benefits

1. Optimum hardening
2. Distortion and crack free hardening of the workload.
3. Absence of oxidation, decarburization or carburization on the surface of work piece.
4. Reduced or no post-hardening and finished costs.
5. Prevent surface reaction such as oxidation or decarburizing on work pieces thus retaining a clean surface intact.
6. Remove surface contaminants such as oxide films and residual traces of lubricants resulting from other operations.

### Disadvantages

1. Cost for hardening increases.
2. The components are to be thoroughly cleaned before hardening in vacuum furnace

### Limitations and problems

1. Volatilization and dissociation in vacuum furnace



**UNIT – III****FERROUS AND NONFERROUS METALS**

Effect of alloying additions on steel-  $\alpha$  and  $\beta$  stabilisers–  
 Stainless and tool steels –  
 HSLA, Maraging steels –  
 Cast Iron – Grey, white, malleable, spheroidal – alloy cast irons,  
 Copper and copper alloys – Brass, Bronze and Cupronickel –  
 Aluminium and Al-Cu – precipitation strengthening treatment –  
 Bearing alloys, Mg-alloys,  
 Ni-based super alloys and  
 3.10 Titanium alloys.

**3.1 CARBON ( C )**

Carbon is present in all steel and is the principal hardening element, determining the level of hardness or strength attainable by quenching. It raises tensile strength, hardness, resistance to wear and abrasion as the carbon content of steel is increased. It lowers ductility, toughness and machinability. Carbon has a moderate tendency to segregate within the ingot.

**ALUMINUM ( AL )**

Strongest and most frequently used deoxidiser and degasifier, favors insensibility to aging. Added in small amounts, it helps fine grain formation. Since it combines with nitrogen to form very hard nitride, it is a favorable alloy constituent in nitriding steels. Aluminum - killed steels exhibit a high order of fracture toughness.

**ANTIMONY ( Sb )**

Harmful to steel, as it generally diminishes toughness.

**ARSENIC ( As )**

Injurious to steel as it increases temper brittleness, decreases toughness and impairs weldability.

**BERYLLIUM ( Be )**

Used for precipitation hardening with some sacrifice of toughness. Very susceptible to deoxidization. Strong affinity to sulfur, rarely used for steel alloys.

**BORON ( B )**

Added in amounts of 0.0005% to 0.03% it significantly increases the harden ability of steel. This effect on harden ability is particularly effective at lower carbon levels. Unlike many other elements boron does not affect the ferrite strength of steel. It can be used to increase the harden ability of steel without sacrificing ductility, formability or machinability of steel in the annealed condition.

**CALCIUM ( Ca )**

In the silicocalcium combination, it is used for deoxidization. Calcium enhances the non-scaling properties of heat conductor alloys

**CHROMIUM ( Cr )**

Of all the common alloying elements, chromium ranks near the top in promoting harden ability. It makes the steel apt for oil or air hardening. It reduces the critical cooling rate required for martensite formation, increases harden ability and thus improves the aptitude for heat treatment. On the other hand, impact strength is weakened. Chromium forms carbides that improve edge-holding capacity and wear resistance. High temperature strength and resistance to high pressure hydrogenation are also enhanced. Non-scaling properties are boosted by increasing chromium contents. A chromium content of 3.99% has been established as the maximum limit applicable to constructional alloy steels. Contents above this level place steels in the category of heat resisting or stainless steels.

**COBALT ( Co )**

Does not create carbides, it inhibits grain growth at elevated temperatures and considerably improves the retention of hardness and hot strength. Therefore it is a frequent alloy constituent in high speed steels, hot work steels and high-temperature steels. It encourages the formation of graphite. It also intensifies the individual effects of other major elements in more complex steels.

**COPPER ( Cu )**

Is added to steel primarily to improve the steel's resistance to atmospheric corrosion. Amounts added to steels for this purpose typically range from 0.20% to 0.50%. Copper is scarcely used for steel alloys because it concentrates under the oxide layer and, by penetrating the grain boundary, imparts the steel a surface liable to suffer in hot working operations. It is therefore regarded as being harmful to steel.

**HYDROGEN ( H )**

Harmful to steel, it causes embrittlement by decreasing of elongation and reduction of area without any increase of yield point and tensile strength. It is the source of the redoubtable snow-flake formation and favors the formation of ghost lines. Atomic hydrogen engendered by pickling penetrates into the steel and forms blowholes. At elevated temperatures moist hydrogen acts as a decarburizing agent.

**LEAD ( Pb )**

Used in quantities of 0.15% to 0.35% for free-machining steel as its very fine, suspension-like distribution ( lead is insoluble in steel ) permits to obtain short chips and clean surfaces, hence an improved machinability. Lead amounts as mentioned above will in no way affect the mechanical properties of steel.

**MANGANESE ( Mn )**

Manganese contributes to strength and hardness, but to a lesser degree than carbon. The amount of increase in these properties is dependent upon the carbon content. Manganese is a deoxidizer and degasifier reacting favorably with sulfur to improve forging ability and surface quality as it converts sulfur to manganese sulfide, thereby, reducing the risk of hot shortness, or susceptibility to cracking and tearing, at rolling temperatures. Manganese increases tensile strength, hardness, harden ability, resistance to wear, and

increases the rate of carbon penetration in carburizing. It has a moderate tendency to segregate. The presence of manganese increases the coefficient of thermal expansion but reduces both thermal and electrical conductivity.

#### MOLYBDENUM ( Mo )

Is chiefly used in conjunction with other alloying elements. Its presence reduces the critical cooling rate and improves harden ability, hardness, and toughness, as well as creep resistance and strength at elevated temperatures. It helps to prevent temper brittleness and promotes fine grained structure. It increases both yield point and tensile strength. It forms carbides readily and thus improves the cutting properties in high speed steels. It improves machinability and resistance to corrosion and it intensifies the effects of other alloying elements.

#### NICKEL ( Ni )

Increases considerably the impact strength of engineering steels, even in low temperature ranges, and is therefore used as an alloying element in steels for case-hardening and for hardening and tempering as well as in low-temperature steels. Nickel lessens distortion in quenching and broadens the temperature range for successful heat treatment. It increases strength and hardness without sacrificing ductility and toughness. It also increases resistance to corrosion and scaling at elevated temperatures when introduced in suitable quantities in high-chromium (Stainless) steels.

#### NITROGEN ( N )

Is present in all steels, but usually in small amounts; it will combine with certain other elements to precipitate as a nitride. This increases hardness, tensile and yield strength, but it decreases toughness and ductility.

#### OXYGEN ( O )

Injurious to steel, its specific influence depends on the type and composition of its compounds in steel and on their shape and distribution. It weakens mechanical properties, in particular impact strength, especially in the transverse direction, whereas the tendency to aging brittleness, red shortness, woody and slanty fracture is increased.

#### PHOSPHORUS ( P )

In appreciable amounts, phosphorus increases the strength and hardness of hot rolled steel to about the same degree as carbon, but at the sacrifice of ductility and toughness, particularly in the quenched and tempered condition. Consequently, for most applications, phosphorus is generally maintained below a specific maximum. This varies with the grade and quality level. In certain low carbon free machining steels, higher phosphorus content is specified for its beneficial effect on machinability. Phosphorus has a pronounced tendency to segregate.

#### SILICON ( Si )

One of the principal deoxidizer used in steel-making and therefore, the amount of silicon present is related to the type of steel. Silicon enhances resistance to scaling and is therefore used as an alloying agent in high temperature steels. Since, however, it impairs hot and cold workability, machinability; its alloying percentages should be

strictly controlled. It has only a slight tendency to segregate. In the lower carbon steels, increased silicon content is detrimental to surface quality. Where silicon killed steel is required, additional billet conditioning is necessary to ensure a good quality surface, particularly with resulfurized steel.

#### SULFUR ( S )

Of all companion elements in steel, sulfur shows the strongest tendency to segregate. Iron sulfide produce red or hot-shortness because the low melting eutectic forms a network around the grains so that these hold but loosely together, and grain boundaries may easily break up during hot forming; these phenomena are even enhanced by oxygen. Since sulfur has a particularly good affinity to manganese, it can be fixed in the form of manganese sulfide which are the least dangerous of all inclusions, being finely dispersed in steel and having a high melting point. Sulfur is used as an alloying addition in free-cutting steels; the finely dispersed sulfide inclusion interrupts the continuity of metal structure, thus producing short chips in machining. Sulfur decreases weldability, impact toughness and ductility.

#### TIN ( Sn )

Can render steel susceptible to temper embrittlement and hot shortness.

#### VANADIUM ( V )

Refines the primary grain; hence also the as-cast structure. Additions of vanadium up to 0.05% increase the harden ability of medium-carbon steels; larger additions appear to reduce the harden ability due to the formation of carbides that have difficulty dissolving in austenite. It is a strong carbide former, increases wear resistance, retention of cutting edges and high temperature strength. Therefore, preferred as an additional alloy material in high speed steels, hot work and high temperature steels. Vanadium greatly improves red hardness and diminishes overheating sensibility.

#### WOLFRAM ( W = TUNGSTEN Tu )

Powerful carbide-former; its carbides are very hard. It improves toughness and inhibits grain growth. It increases hot strength and hardness retention as well as wear resistance at high temperatures (red heat) and cutting power. It is a favorite alloying element in high speed and hot work steels, high temperature steels and super hard steels

precipitation of inter-metallic compounds. The principal alloying element is 15 to 25% nickel. Secondary alloying elements are added to produce intermetallic precipitates, which include cobalt, molybdenum, and titanium. Original development was carried out on 20 and 25% Ni steels to which small additions of Al, Ti, and Nb were made.

The common, non-stainless grades contain 17-19% nickel, 8-12% cobalt, 3-5% molybdenum, 0.2-1.6% titanium. Addition of chromium and produces stainless grades resistant to corrosion. This also indirectly increases hardenability as they require less nickel: high-chromium, high-nickel steels are generally austenitic and unable to transform to martensite when heat treated, while lower-nickel steels can transform to martensite.

#### Properties

Due to the low carbon content maraging steels have good machinability. Prior to aging, they may also be cold rolled to as much as 80- 90% without cracking. Maraging steels offer good weldability, but must be aged afterward to restore the properties of heat affected zone. When heat-treated the alloy has very little dimensional change, so it is often machined to its final dimensions. Due to the high alloy content maraging steels have a high hardenability. Since ductile FeNi martensites are formed upon cooling, cracks are non-existent or negligible. The steels can be nitrided to increase case hardness, and polished to a fine surface finish.

Non-stainless varieties of maraging steel are moderately corrosion- resistant, and resist stress corrosion and hydrogen embrittlement. Corrosion- resistance can be increased by cadmium plating or phosphating.

### Types of Cast Iron:

Major types of cast iron are shown in Figure 1.4

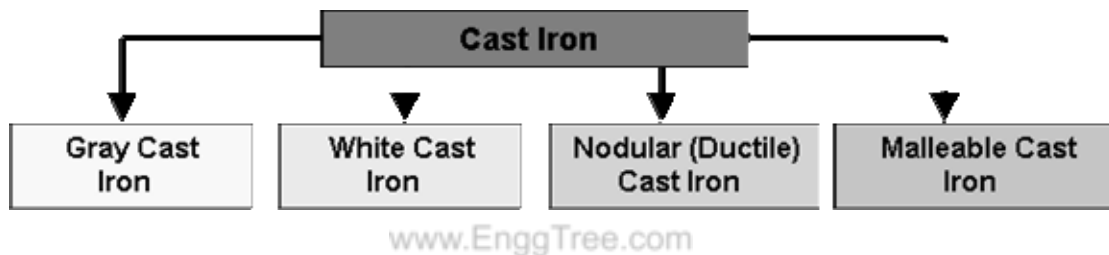

Figure 1.4 Types of Cast Iron

### Gray Cast Iron:

Gray cast iron is by far the oldest and most common form of cast iron. As a result, it is assumed by many to be the only form of cast iron and the terms "cast iron" and "gray iron" are used interchangeably. Unfortunately the only commonly known property of gray iron- brittleness- is also assigned to "cast iron" and hence to all cast irons. Gray iron, named because its fracture has a gray appearance. It contains carbon in the form of flake graphite in a matrix which consists of ferrite, pearlite or a mixture of the two. The fluidity of liquid gray iron, and its expansion during solidification due to the formation of graphite, have made this metal ideal for the economical production of shrinkage-free, intricate castings such as motor blocks.

The flake-like shape of graphite in Gray iron, see Figures 1.5 and 1.6, exerts a dominant influence on its mechanical properties. The graphite flakes act as stress raisers which may prematurely cause localized plastic flow at low stresses, and initiate fracture in the matrix at higher stresses. As a result, Gray iron exhibits no elastic behavior but excellent damping characteristics, and fails in tension without significant plastic deformation. The presence of graphite flakes also gives Gray Iron excellent machinability and self-lubricating properties.



## Flakes

Figure 1.5 Graphite Flakes in Gray Cast iron



Figure 1.6 Photomicrograph of Gray Cast iron

Advantages of Gray Cast Iron: [www.EnggTree.com](http://www.EnggTree.com)

- Graphite acts as a chip breaker and a tool lubricant. Very high damping capacity.
- Good dry bearing qualities due to graphite. After formation of protective scales, it resists corrosion in many common engineering environments.

Disadvantages:

Brittle (low impact strength) which severely limits use for critical applications. Graphite acts as a void and reduces strength. Maximum recommended design stress is 1/4 of the ultimate tensile strength. Maximum fatigue loading limit is 1/3 of fatigue strength. Changes in section size will cause variations in machining characteristics due to variation in microstructure. Higher strength gray cast irons are more expensive to produce.

Low Alloy Gray Cast Iron:

Enables gray cast iron to be used in higher duty applications without redesign or need for costly materials.

Advantages:

- Reduction in section sensitivity.
- Improvement in strength, corrosion resistance, heat and wear resistance or combination of these properties.

## ME3392 – ENGG. MATERIALS AND METALLURGY

## Disadvantages:

- Higher cost.
- Alloy additions can cause foundry problems with reuse of scrap (runners, risers, etc) and interrupt normal production.
- Increase in strength does not bring corresponding increase in fatigue strength.
- Cr, Mo and V are carbide stabilizers which improve strength and heat resistance but impair machinability.

## White Cast Iron:

White cast iron is unique in that it is the only member of the cast iron family in which carbon is present only as carbide. Due to the absence of graphite, it has a light appearance. The presence of different carbides, depending on the alloy content, makes white cast irons extremely hard and abrasion resistant but very brittle. An improved form of white cast iron is the chilled cast iron.

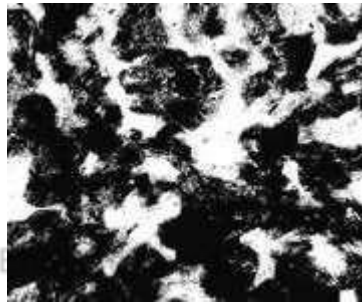

Figure 1.7 Photomicrograph of White Cast Iron

## Chilled Cast Iron:

When localized area of a gray cast iron is cooled very rapidly from the melt, cast iron is formed at the place that has been cooled. This type of white cast iron is called chilled iron. A chilled iron casting can be produced by adjusting the carbon composition of the white cast iron so that the normal cooling rate at the surface is just fast enough to produce white cast iron while the slower cooling rate below the surface will produce gray iron. The depth of chill decreases and the hardness of the chilled zone increases with increasing carbon content.

Chromium is used in small amounts to control chill depth. Because of the formation of chromium carbides, chromium is used in amount of 1 to 4 percent in chilled iron to increase hardness and improve abrasion resistance. It also stabilizes carbide and suppresses the formation of graphite in heavy sections. When added in amounts of 12 to 35 percent, chromium will impart resistance to corrosion and oxidation at elevated temperatures.

## ME3392 – ENGG. MATERIALS AND METALLURGY

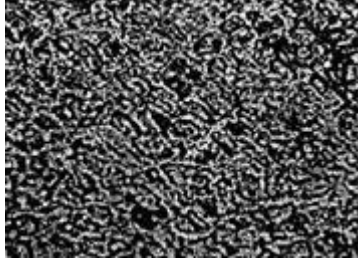

Figure 1.8 Photomicrograph of Chilled Cast Iron

Fast cooling prevents graphite and pearlite formation. If alloys such as nickel, chromium, or molybdenum are added, much of the austenite transforms to martensite instead of pearlite. The hardness of chilled cast iron is generally due to the formation of martensite.

Chilled cast iron is used for railway-car wheels, crushing rolls, stamp shoes and dies, and many heavy-duty machinery parts.

#### Ductile Cast Iron (Nodular Cast Iron):

This structure is developed from the melt. The carbon forms into spheres when cerium, magnesium, sodium, or other elements are added to a melt of iron with a very low sulfur content that will inhibit carbon from forming. The control of the heat-treating process can yield pearlitic, ferritic, martensitic matrices into which the carbon spheres are embedded.

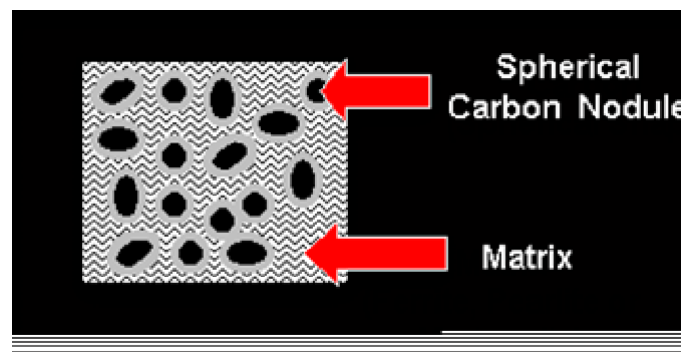
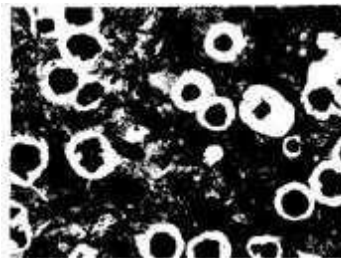

Figure 1.9. Nodular (Ductile) Cast Iron and the spherical carbon embedded into the matrix.





## ME3392 – ENGG. MATERIALS AND METALLURGY

Figure 1.10 Photomicrograph of Nodular Cast iron

The advantages of ductile cast iron which have led to its success are numerous, but they can be summarized easily- versatility and high performance at low cost. Other members of the ferrous casting family may have superior individual properties which might make them the material of choice in some applications, but none have the versatility of ductile cast iron, which often provides the designer with the best combination of overall properties. This is especially evident in the area of mechanical properties where ductile cast iron offers the designer the option of selecting high ductility, with grades guaranteeing more than 18% elongation (as high as 25 %), or high strength, with tensile strengths exceeding 120 Ksi. Austempered ductile iron offers even greater mechanical and wear resistance, providing tensile strengths exceeding 230 Ksi.

In addition to cost advantages offered by all castings, ductile cast iron, when compared to steel and malleable cast iron, also offers further cost savings. Like most commercial cast metal, steel and malleable cast iron decrease in volume during solidification, and as a result, require feeders and risers to offset the shrinkage and prevent the formation of internal or external shrinkage defects. Ductile cast iron offers significantly low shrinkage during casting. In the case of large castings produced in rigid molds, it does not require feeders. In other cases, it requires feeders that are much smaller than those used for malleable cast iron and steel. This reduced requirement for feed metal increases the productivity of ductile cast iron and reduces its material and energy requirements, resulting in substantial cost savings. The use of the most common grades of ductile cast iron "as-cast" eliminates heat treatment costs, offering a further advantage.

Ductile cast iron is used for many structural applications, particularly those requiring strength and toughness combined with good machinability and low cost. The automotive and agricultural industries are the major users of ductile iron castings. Because of economic advantage and high reliability, ductile iron is used for such critical automotive parts as crankshafts, engine connecting rods, idler arms, wheel hubs, truck axles, front wheel spindle supports, disk brake calipers, suspension system parts, power transmission yokes, high temperature applications for turbo housing and manifolds, and high security valves for many applications. The cast iron pipe industry is another major user of ductile iron.

#### Malleable Cast Iron:

If cast iron is cooled rapidly, the graphite flakes needed for gray cast iron do not get a chance to form. Instead, white cast iron forms. This white cast iron is reheated to about 1700°F for long periods of time in the presence of materials containing oxygen, such as iron oxide. At the elevated temperatures cementite ( $Fe_3C$ ) decomposes into ferrite and free carbon. Upon cooling, the combined carbon further decomposes to small compact particles of graphite (instead of flake-like graphite seen in gray cast iron). If the cooling is very slow, more free carbon is released. This free carbon is referred to as temper carbon, and the process is called malleabilizing.

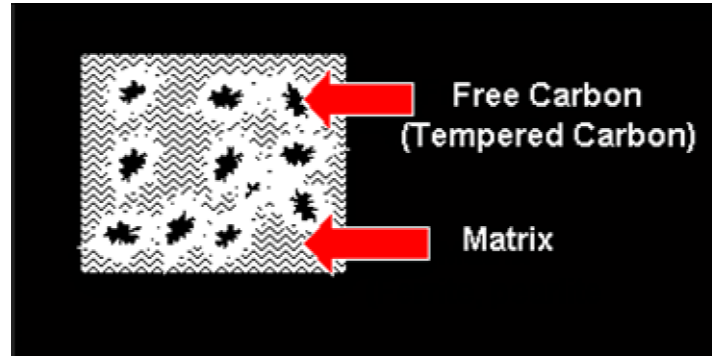

Figure 1.11 Malleable Cast Iron

Figure 8 shows ferritic malleable cast iron, which has a ferrite matrix and the tempered carbon particles are embedded into the matrix.

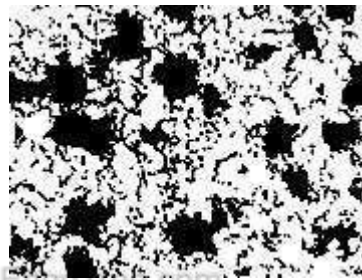

Figure 1.12 Ferritic Malleable Cast iron

Figure 9 shows pearlite malleable cast iron, which has a pearlite matrix. By adding manganese to the structure, carbon is retained in the form of cementite.

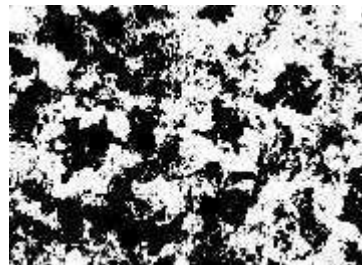

Figure 1.13. Pearlitic Malleable Cast Iron

A wide variety of physical properties can be obtained by heating and cooling through the eutectoid temperature or by adding alloying elements. Slow cooling will cause the cementite to decompose and release more free carbon (temper carbon). Fast cooling will retain some of the cementite. The amount retained, will depend on the rapidity of cooling. Malleable cast iron is used for connecting rods and universal joint yokes, transmission gears, differential cases and certain gears, compressor crankshafts and hubs, flanges, pipe fittings and valve parts for railroad, marine and other heavy-duty applications.

## Advantages:

- Excellent machinability Significant ductility
- Good shock resistance properties

## Disadvantages:

The major disadvantage is shrinkage. Malleable cast iron decreases in volume during solidification, and as a result, requires attached reservoirs (feeders and risers) of liquid metal to offset the shrinkage and prevent the formation of internal or external shrinkage defects.

## Classification of Cu alloys

Copper and copper alloys are designated according to the Copper Development Association (CDA).

1. Wrought alloys (C100 – C799 )
2. Cast alloys (C800-C999)

## Copper alloys

## Unalloyed copper - Wrought Cu

- Cu- Ni Based
- Cu-Ni (Cupronickel)
- Cu-Ni-Zn ( Nickel Silver )

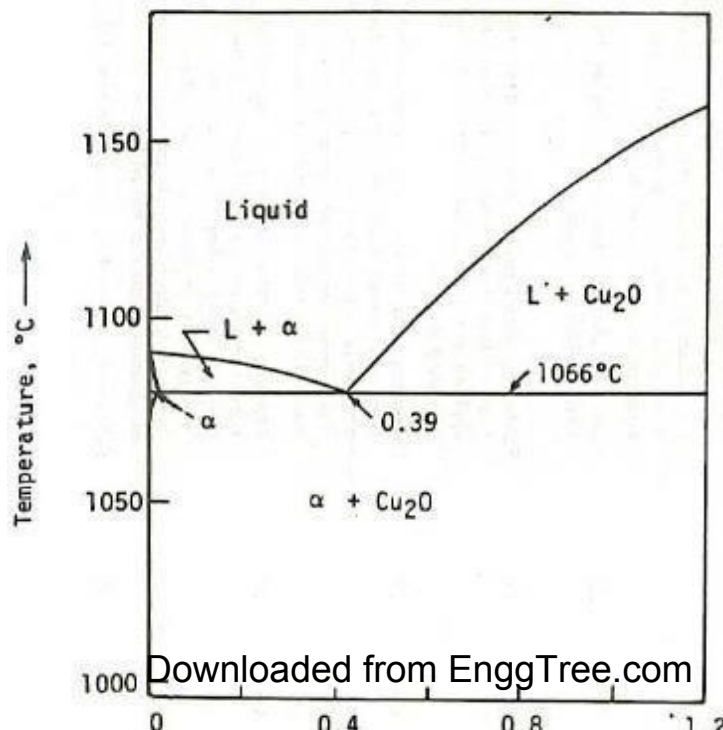

Prepared by

### Brass

- Cu-Zn alloys (brasses)
- Cu-Zn-Pb alloys (leaded brasses)
- Cu-Zn-Sn alloys (Tin brasses)

### Bronze

#### Cu-Sn Bronze

Cu-Al alloys (Aluminium bronze) Cu-Si Bronze (Silicon bronze)

Cu-Mn Bronze (Manganese bronze), Cu-Be Bronze (Beryllium bronze)

#### Wrought Copper

#### Unalloyed Copper

[www.EnggTree.com](http://www.EnggTree.com)

- Good electrical, thermal conductivities
- High corrosion resistance
- Easily fabricated
- Reasonable tensile strength
- Controllable annealing properties
- Good soldering and joining properties

#### Brasses [Cu - Zn alloy]

#### Different kinds of brasses

- Gliding Metal (<5% Zn), Commercial Brass (~10% Zn), Jewelry Brass (~12.5% Zn)
- Red Brass (~15% Zn), Low Brass (Dutch metal) (~20% Zn), Cartridge Brass (~30% Zn)
- Yellow Brass (~35% Zn),
- Naval brass (60% Cu and 39% Zn)
- Muntz Metal (40% Zn)

#### Cu-Zn alloys (Brasses)

#### Cu-Zn Alloys

- Copper and zinc form solid solution up to ~ 39% zinc at 456°C, giving a wide range of properties.
- Sn, Al, Si, Mg, Ni, and Pb are added elements, called ‘alloy brasses’.
- $\alpha$  phase – FCC structure – strong and ductile
- $\beta$  phase – BCC structure (disordered) – hard and ductile
- $\beta'$  phase – BCC structure(ordered) – hard and brittle
- $\gamma$  phase – complex cubic structure -  $\text{Cu}_5\text{Zn}_8$  - weak and brittle

### Classification of brass

1. Wrought brass
  - $\alpha$  brasses
  - $\alpha+\beta$  brasses

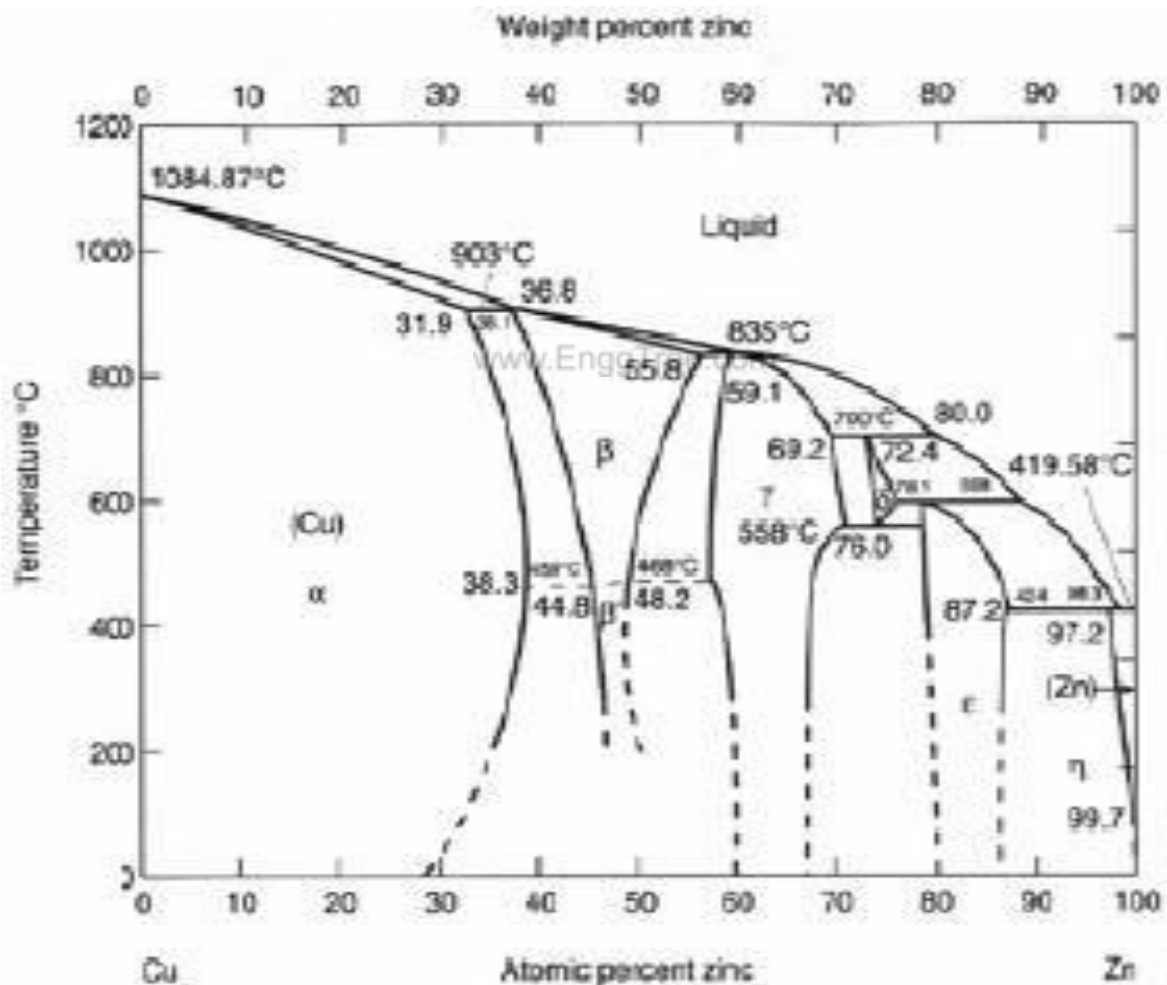

### 2. Cast brass

#### $\alpha$ brasses

- containing upto 36% Zn.
- Excellent cold and hot formability

- 15% Zn – red brass
- 20-36% Zn – yellow brass
- 30% Zn – Cartridge brass
- Microstructures of the single phase  $\alpha$  brasses consist of  $\alpha$  solid solution - Called as cold worked brass

#### Applications:

Coins, medals, jewelry, marine hardwares, Architectural trims, bullet envelopes, electric sockets, lamp fixtures, musical instruments etc...

#### $\alpha + \beta$ brasses

- 40% Zn addition provides a complex structure of  $\alpha$  and  $\beta$  phases.
- 60% Cu-40% Zn (Muntz metal) is the most widely used.
- $\beta$  phase makes this alloy heat-treatable.

#### Applications:

Condenser heads, architectural work, large nuts and bolts, valve stems, marine hardware, piston rods etc.

#### Cast brasses

- Liquidus and solidus are very close to each other – high fluidity and less segregation
- Other alloying are added to improve properties

#### Mechanical properties $\alpha$ brass

- Zn increases, strength, ductility, hardness
- Colour changes increases, Red.....> Yellow
- Can be hot worked in 730-900°C temperature range.
- Annealed low brass is extremely ductile (40-50% at RT) and malleable.

#### $\alpha + \beta$ brass

- Increased strength and hardness due to increasing Zn content.
- Decreased ductility due to the presence of the  $\beta$  phase (BCC).
- The  $\alpha + \beta$  brasses are difficult to cold-work, due to increasing amount of  $\beta$  phase.

#### Corrosion of brasses Stress corrosion cracking

- $\alpha$  brasses in the cold worked condition and containing more than about 15% Zn when contact with a trace of ammonia.
- It occurs along the grain boundaries (intergranular cracking)
- It is also called as season cracking

#### Dezincification

The Zn corrodes preferentially and leaves a porous residue of copper and corrosion products.

## Alloy Brasses

- 1% of Sn addition in cartridge brass improve corrosion resistance in sea water.
- 0.04% arsenic addition could almost eliminate dezincification (corrosion condition).
- Replacing Sn with Al gives brass a self-healing protective oxide on its surface. This is Called Aluminium brasses which has corrosion resistance used for marine condensers.
- Addition of Pb, increases the forging property of brass.

steels (from martensitic and aging) are steels (iron alloys) which are known for possessing superior strength and toughness without losing malleability, although they cannot hold a good cutting edge. Aging refers to the extended heat-treatment process. These steels are a special class of low- carbon ultra- high-strength steels which derive their strength not from carbon, but from

**4.HEAT TREATMENT CYCLE**

The steel is first annealed at approximately 820 °C (1,510 °F) for 15- 30 minutes for thin sections and for 1 hour per 25 mm thickness for heavy sections, to ensure formation of a fully austenitized structure. This is followed by air cooling to room temperature to form a soft, heavily-dislocated iron-nickel lath (untwinned) martensite. Subsequent aging (precipitation hardening) of the more common alloys for approximately 3 hours at a temperature of 480 to 500 °C produces a fine dispersion of Ni<sub>3</sub>(X,Y) intermetallic phases along dislocations left by martensitic transformation, where X and Y are solute elements added for such precipitation. Overaging leads to a reduction in stability of the primary, metastable, coherent precipitates, leading to their dissolution and replacement with semi-coherent Laves phases such as Fe<sub>2</sub>Ni/Fe<sub>2</sub>Mo. Further excessive heat- treatment brings about the decomposition of the martensite and reversion to austenite.

Newer compositions of maraging steels have revealed other intermetallic stoichiometries and crystallographic relationships with the parent martensite, including rhombohedral and massive complex Ni<sub>50</sub>(X,Y,Z)<sub>50</sub> (Ni<sub>50</sub>M<sub>50</sub> in simplified notation).

**Uses**

Maraging steel's strength and malleability in the pre-aged stage allows it to be formed into thinner rocket and missile skins than other steels, reducing weight for a given strength. Maraging steels have very stable properties, and, even after overaging due to excessive temperature, only soften slightly. These alloys retain their properties at mildly elevated operating temperatures and have maximum service temperatures of over 400 °C (752 °F)

They are suitable for engine components, such as crankshafts and gears, and the firing pins of automatic weapons that cycle from hot to cool repeatedly while under substantial load. Their uniform expansion and easy machinability before aging make maraging steel useful in high-wear components of assembly lines and dies. Other ultra-high-strength steels, such as Aermet alloys, are not as machinable because of their carbide content.

In the sport of fencing, blades used in competitions run under the auspices of the Fédération Internationale d'Escrime are often made with maraging steel. Maraging blades are required in foil and épée because crack propagation in maraging steel is 10 times slower than in carbon steel, resulting in less blade breakage and fewer injuries. The notion that such blades break flat is a fencing urban legend: testing has shown that the blade-breakage patterns in carbon steel and maraging steel blades are identical.

Stainless maraging steel is used in bicycle frames and golf club heads. It is also used in surgical components and hypodermic syringes, but is not suitable for scalpel blades because the lack of carbon prevents it from holding a good cutting edge. Maraging steel production, import, and export by certain states, such as the

United States, is closely monitored by international authorities because it is particularly suited for use in gas centrifuges for uranium enrichment; lack of maraging steel significantly hampers this process. Older centrifuges used aluminum tubes; modern ones, carbon fiber composite.

**Copper alloys** are metal alloys that have copper as their principal component. They have high resistance against corrosion. The best known traditional types are bronze, where tin is a significant addition, and brass, using zinc instead. Both these are imprecise terms, and today the term copper alloy tends to be substituted, especially by museums.

### Compositions

The similarity in external appearance of the various alloys, along with the different combinations of elements used when making each alloy, can lead to confusion when categorizing the different compositions. There are as many as 400 different copper and copper-alloy compositions loosely grouped into the categories: copper, high copper alloy, brasses, bronzes, copper nickels, copper-nickel-zinc (nickel silver), leaded copper, and special alloys. The following table lists the principal alloying element for four of the more common types used in modern industry, along with the name for each type. Historical types, such as those that characterize the Bronze Age, are vaguer as the mixtures were generally variable.

## 5. CLASSIFICATION OF COPPER AND ITS ALLOYS

### 1. BRASSES

A brass is an alloy of copper with zinc. Brasses are usually yellow in color. The zinc content can vary between few % to about 40%; as long as it is kept under 15%, it does not markedly decrease corrosion resistance of copper. Brasses can be sensitive to selective leaching corrosion under certain conditions, when zinc is leached from the alloy (dezincification), leaving behind a spongy copper structure.

### 2. BRONZES

A bronze is an alloy of copper and other metals, most often tin, but also aluminium and silicon.



Aluminium bronzes are alloys of copper and aluminium. The content of aluminium ranges mostly between 5-11%. Iron, nickel, manganese and silicon are sometimes added. They have higher strength and corrosion resistance than other bronzes, especially in marine environment, and have low reactivity to sulfur compounds. Aluminium forms a thin passivation layer on the surface of the metal.

### CARBON STEELS

Carbon steels are iron-carbon alloys containing up to 2.06% of carbon, up to 1.65% of manganese, up to 0.5% of silicon and sulfur and phosphorus as impurities. Carbon content in carbon steel determines its strength and ductility. The higher carbon content, the higher steel strength and the lower its ductility.

### ALLOY STEELS

Alloy steels are iron-carbon alloys, to which alloying elements are added with a purpose to improve the steels properties as compared to the Carbon steels. Due to effect of alloying elements, properties of alloy steels exceed those of plain carbon steels. AISI/SAE classification divide alloy steels

According to the four-digit classification SAE/AISI system: First digit indicates the class of the alloy steel:

- 2- Nickel steels;
- 3-Nickel-chromium steels;
- 4- Molybdenum steels;
- 5- Chromium steels;
- 6-Chromium-vanadium steels;
- 7-Tungsten-chromium steels;
- 9- Silicon-manganese steels.

Second digit indicates concentration of the major element in percents (1 means 1%).

Last two digits indicate carbon concentration in 0,01%.

Example: SAE 5130 means alloy chromium steel, containing 1% of chromium and 0.30% of carbon.

### 3. TOOL AND DIE STEELS

Tool and die steels are high carbon steels (either carbon or alloy) possessing high hardness, strength and wear resistance. Tool steels are heat treatable. In order to increase hardness and wear resistance of tool steels, alloying elements forming hard and stable carbides (chromium, tungsten, vanadium, manganese, molybdenum) are added to the composition. Designation

system of one-letter in combination with a number is accepted for tool steels. The letter means:W  
- Water hardened plain carbon tool steels

Applications: chisels, forging dies, hammers, drills, cutters, shear blades, cutters, drills, razors.

Properties: low cost, very hard, brittle, relatively low harden ability, suitable for small parts working at not elevated temperatures.

O, A, D - Cold work tool steels

Applications: drawing and forging dies, shear blades, highly effective cutters. Properties: strong, hard and tough crack resistant.

O -Oil hardening cold work alloy steels;

A -Air hardening cold work alloy steels;

D -Diffused hardening cold work alloy steels;

S - Shock resistant low carbon tool steels

Applications: tools experiencing hot or cold impact.

Properties: combine high toughness with good wear resistance.

T,M – High speed tool steels (T-tungsten, M-molybdenum)

Applications: cutting tools. Properties: high wear heat and shock resistance.

H – Hot work tool steels

Applications: parts working at elevated temperatures, like extrusion, casting and forging dies.

Properties: strong and hard at elevated temperatures.

P - Plastic mold tool steels

Applications: molds for injection molding of plastics.

Properties: good machinability.

Chemical compositions of some tool and die steels

## 6.EFFECTS OF ALLOYING ELEMENTS IN STEEL

Steel is basically iron alloyed to carbon with certain additional elements to give the required properties to the finished melt. Listed below is a summary of the effects various alloying elements in steel.

#### Carbon

The basic metal, iron, is alloyed with carbon to make steel and has the effect of increasing the hardness and strength by heat treatment but the addition of carbon enables a wide range of hardness and strength.

#### Manganese

Manganese is added to steel to improve hot working properties and increase strength, toughness and hardenability. Manganese, like nickel, is an austenite forming element and has been used as a substitute for nickel in the A.I.S.I 200 Series of Austenitic stainless steels (e.g. A.I.S.I 202 as a substitute for A.I.S.I 304)

#### Chromium

Chromium is added to the steel to increase resistance to oxidation. This resistance increases as more chromium is added. 'Stainless Steel' has approximately 11% chromium and a very marked degree of general corrosion resistance when compared with steels with a lower percentage of chromium. When added to low alloy steels, chromium can increase the response to heat treatment, thus improving hardenability and strength.

#### Nickel

Nickel is added in large amounts, over about 8%, to high chromium stainless steel to form the most important class of corrosion and heat resistant steels. These are the austenitic stainless steels, typified by 18-8, where the tendency of nickel to form austenite is responsible for a great toughness and high strength at both high and low temperatures. Nickel also improves resistance to oxidation and corrosion. It increases toughness at low temperatures when added in smaller amounts to alloy steels.

#### Molybdenum

Molybdenum, when added to chromium-nickel austenitic steels, improves resistance to pitting corrosion especially by chlorides and sulphur chemicals. When added to low alloy steels, molybdenum improves high temperature strengths and hardness. When added to chromium steels it greatly diminishes the tendency of steels to decay in service or in heat treatment.

#### Titanium

The main use of titanium as an alloying element in steel is for carbide stabilisation. It combines with carbon to form titanium carbides, which are quite stable and hard to dissolve in steel, this tends to minimise the occurrence of inter-granular corrosion, as with A.I.S.I 321, when adding approximately 0.25%/0.60% titanium, the carbon combines with the titanium in preference to chromium, preventing a tie-up of corrosion resisting chromium as inter-granular carbides and the accompanying loss of corrosion resistance at the grain boundaries.

### Phosphorus

Phosphorus is usually added with sulphur to improve machinability in low alloy steels, phosphorus, in small amounts, aids strength and corrosion resistance. Experimental work shows that phosphorus present in austenitic stainless steels increases strength. Phosphorus additions are known to increase the tendency to cracking during welding.

### Sulphur

When added in small amounts sulphur improves machinability but does not cause hot shortness. Hot shortness is reduced by the addition of manganese, which combines with the sulphur to form manganese sulphide. As manganese sulphide has a higher melting point than iron sulphide, which would form if manganese were not present, the weak spots at the grain boundaries are greatly reduced during hot working.

www.EnggTree.com

### Selenium

Selenium is added to improve machinability.

### Niobium (Columbium)

Niobium is added to steel in order to stabilise carbon, and as such performs in the same way as described for titanium. Niobium also has the effect of strengthening steels and alloys for high temperature service.

### Nitrogen

Nitrogen has the effect of increasing the austenitic stability of stainless steels and is, as in the case of nickel, an austenite forming element. Yield strength is greatly improved when nitrogen is added to austenitic stainless steels.

### Silicon

Silicon is used as a deoxidising (killing) agent in the melting of steel, as a result, most steels contain a small percentage of silicon. Silicon contributes to hardening of the ferritic phase in steels and for this reason silicon killed steels are somewhat harder and stiffer than aluminium killed steels.

#### Cobalt

Cobalt becomes highly radioactive when exposed to the intense radiation of nuclear reactors, and as a result, any stainless steel that is in nuclear service will have a cobalt restriction, usually approximately 0.2% maximum. This problem is emphasised because there is residual cobalt content in the nickel used in producing these steels.

#### Tantalum

Chemically similar to niobium and has similar effects.

#### Copper

Copper is normally present in stainless steels as a residual element. However it is added to a few alloys to produce precipitation hardening properties.

**UNIT IV**

Properties and application of Polymer

PP

PS

PVC

PMMA

PET

PC

PA

ABS

PI

PAI

PPO

PPS

PEEK

PTFE

Urea

Phenol formaldehyde

Properties and application of ceramics

$Al_2O_3$

SIC

$Si_3N_4$

PSZ

SIALON

Classification composite

[www.EnggTree.com](http://www.EnggTree.com)

[www.EnggTree.com](http://www.EnggTree.com)

## NON METALLIC MATERIALS

## Typical Commodity and Engineering Polymers/Plastics-Properties and Applications

Polymers such as polyethylene, polypropylene, PVC etc which does not have excellent mechanical and thermal properties are used in high volume in non-structural applications are termed commodity polymers. Polymers which possess properties such as

i) Excellent mechanical properties over temperatures from below  $-40^{\circ}\text{C}$  ( $-40^{\circ}\text{F}$ ) to above  $148^{\circ}\text{C}$  ( $300^{\circ}\text{F}$ ), ii) Self-extinguishing, non-dripping characteristics, iii) Excellent durability, dimensional stability and low water absorption, iv) Resistance to aqueous chemical environments and v) Excellent impact strength, are classified as engineering polymers/plastics . Ex., polyphenylene oxide, PEEK, polyethylene terephthalate, polyphenylene sulphide, Teflon, Kevlar, polyimide, polyeterimide, ABS etc.

## Polypropylene

Polypropylene(thermoplastic, melting temperature:  $174^{\circ}\text{C}$ ; glass transition temperature:  $-17^{\circ}\text{C}$ ) is a versatile commodity polymer. It serves double duty, both as a plastic and as a fiber. As a plastic it's used to make things like dishwasher-safe food containers. It can do this because it doesn't melt below  $160^{\circ}\text{C}$ , or  $320^{\circ}\text{F}$ . Polyethylene, a more common plastic, will anneal at around  $100^{\circ}\text{C}$ , which means that polyethylene dishes will warp in the dishwasher. As a fiber, polypropylene is used to make indoor-outdoor carpeting, used around swimming pools and miniature golf courses. It works well for outdoor carpet because it is easy to make colored polypropylene, and because polypropylene doesn't absorb water, like nylon does.

[www.EnggTree.com](http://www.EnggTree.com)

It is slightly more susceptible than polyethylene to strong oxidizing agents. It offers the best stress- crack resistance of the polyolefins. Products made of polypropylene are brittle at  $0^{\circ}\text{C}$  and may crack or break if dropped from benchtop height. Polypropylene can be made from the monomer propylene by Ziegler-Natta polymerization and by metallocene catalysis polymerization.

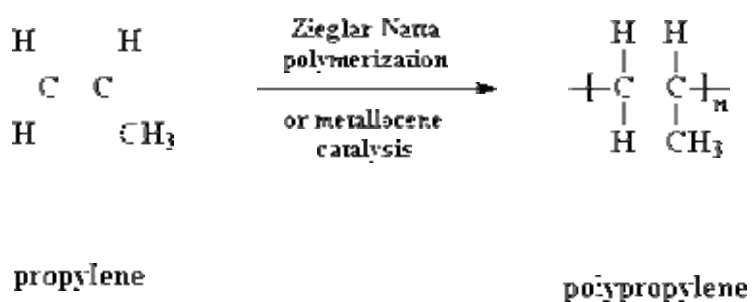





Cross-linked high-density polyethylene (XLPE) is a form of high-density polyethylene wherein the individual molecular chains are bonded to each other (using heat, plus chemicals or radiation) to form a three-dimensional polymer of extremely high molecular weight. This structure provides superior stress-crack resistance and somewhat improves the toughness, stiffness and chemical resistance of HDPE. XLPE is a superior material for moulding very large storage tanks.

### Polystyrene

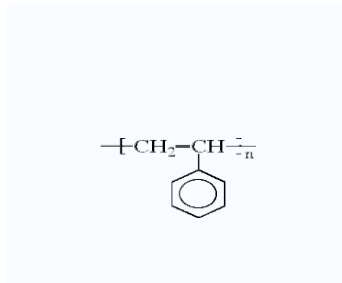

Polystyrene is normally a solid thermoplastic, but can be melted at higher temperature for molding or extrusion, then resolidified. It is an amorphous and its glass transition temperature is 100°C. Polystyrene is an aromatic polymer. Polystyrene is also used as a building material, with electrical appliances (light switches and plates), and in other household items. Polystyrene can be transparent or can be made to take on various colors. It is economical and is used for producing plastic model assembly kits, plastic cutlery, CD "jewel" cases, and many other objects where a fairly rigid, economical plastic of various colors is desired. For architectural and engineering modelling, polystyrene is extruded into forms of standard modelling scale with the cross-sections of a miniature I-beam as well as rods and tubes. It is also formed into sheets with various patterns for this purpose as well. The blank sheets of polystyrene are referred to as "plasticard". Polystyrene fabricated into a sheet can be stamped (formed) into economic, disposable cups, glasses, bowls, lids, and other items, especially when high strength, durability, and heat resistance are not essential. A thin layer of transparent polystyrene is often used as an infra-red spectroscopy standard.

The outside housing of the computer is probably made of polystyrene. Model cars and airplanes are made from polystyrene, and it also is made in the form of foam packaging and insulation (Styrofoam™ is one brand of polystyrene foam). Clear plastic drinking cups are made of polystyrene. So are a lot of the molded parts on the inside of car, like the radio knobs. Polystyrene is also used in toys, and the housings of things like hairdryers, computers, and kitchen appliances.

Expanded polystyrene is very easily cut with a hot-wire foam cutter, which is easily made by a heated and taut length wire, usually nichrome due to its thermal conductance. Hot wire foam cutters work by heating special wire (usually nichrome or stainless steel) to the point where it can vaporize foam immediately adjacent to it. The foam gets vaporized before actually touching the heated wire, which yields exceptionally smooth cuts. Polystyrene, shaped and cut with hot wire foam cutters, is used in architecture models, actual signage, amusement park and movie sets, airplane construction, and much more.

Polystyrene's most common use, however, is as expanded polystyrene, which is a mixture of about 5% polystyrene and 95% gaseous blowing agent. This is the lightweight material of which coffee cups and takeaway food containers are made. The voids filled with trapped air give expanded polystyrene low thermal conductivity. This makes it ideal as a construction material and is used in structural insulated panel building systems. It is also used as insulation in building structures, as packing material for cushioning inside boxes, as non-weight bearing architectural structures (such as pillars) and also in crafts.

and model building, particularly architectural models. Foamed between two sheets of paper, it makes a more-uniform substitute for corrugated cardboard tradenamed *Foamcore*. Expanded polystyrene used to contain CFCs but other, more environmentally-safe blowing agents are now used. Because it is an aromatic hydrocarbon, polystyrene is flammable and burns with an orange-yellow flame giving off soot, as opposed to non-aromatic hydrocarbon polymers such as polyethylene, which burn with a light yellow flame (often with a blue tinge) and no soot. Production methods include sheet stamping (PS) and injection molding (both PS and HIPS).

### Toughening of Polystyrene

Pure polystyrene is brittle, but hard enough that a fairly high-performance product can be made by giving it some of the properties of a stretchier material, such as polybutadiene rubber. The two materials cannot normally be mixed due to the amplified effect of intermolecular forces on polymer solubility (see plastic recycling), but if polybutadiene is added during polymerization it can become chemically bonded to the polystyrene, forming a graft copolymer which helps to incorporate normal polybutadiene into the final mix, resulting in high-impact polystyrene or HIPS, often called "high-impact plastic" in advertisements. Common applications include use in toys and product casings. HIPS is usually injection molded in production.

### Polyvinyl chloride(PVC)( VINYL Plastic)



Polyvinyl chloride is obtained by suspension or bulk free radical polymerization of vinyl chloride. It is an amorphous polymer( thermo plastic) having glass transition temperature around 87°C. It is an unstable polymer compared to the other commodity polymers like PE, PP etc. Its commercial success is attributed to the discovery of suitable stabilizers and other additives. Lead compounds ( lead stearate etc ), organo tin compounds( dibutyl tin dilaurate etc) etc are used as stabilizers. About 50% of produced PVC is used as rigid resins ( ex in PVC pipes etc). Flexible PVC is made via plasticization using plasticizers such as dioctyl phthalate, dioctyl adipate, tricresyl phosphate etc. Building construction market account for 30 % of its production. which include pipe and fittings, siding, carpet backing, windows gutters, wall coverings etc . Bottles and packaging sheet are also major rigid markets. Flexible vinyl is used in wire and cable insulation, film and sheet, floor coverings, synthetic leather products, coatings, blood bags, medical tubing and many other applications. Plasticized PVC is melt processed. PVC has a good resistance to hydrocarbons. Its application is widened using fillers, pigments, impact modifiers etc.

### Poly(methyl methacrylate) (Diakon, Lucite, Oroglas, Perspex, Plexiglas)

PMMA is an amorphous( glass transition 105°C), transparent and colourless thermoplastic that is hard and stiff but brittle and notch-sensitive. It has good abrasion and UV resistance and excellent optical clarity but poor low temperature, fatigue and solvent and scratch resistances. Though flammable, it has low smoke emission. General purpose grades can be extruded and injection moulded. Monomer casting is also used to achieve much higher molecular weights - which are not melt processable because of their extremely high melt viscosity - with somewhat improved properties. The monomer cast items most commonly encountered are sheets and novelty displays in which e.g. insects or watch parts are embedded. Thin films are normally made from impact modified grades, which incorporate a small proportion of elastomer(s), in order to improve their flexibility. Perspex CQ is a particular example of monomer cast sheet which was, until recently, made for intra- ocular

use and they are additive-free and the purest (and probably the highest molecular weight) grade of PMMA available. Applications include sinks, baths, displays, signs, glazing (especially aircraft), lenses and light covers. Cast sheet is also used for guards and the like.

PMMA is used for instance in the rear lights of cars. The spectator protection in ice hockey stadiums is made of PMMA as are the very largest windows and fish tanks in the world. The material is used to produce laserdiscs, and sometimes also for DVDs, but the more expensive polycarbonate (also used for CDs) has better properties when exposed to moisture. PMMA has a good degree of compatibility with human tissue, and can be used for replacement intraocular lenses in the eye when the original lens has been removed in the treatment of cataracts. Hard contact lenses are frequently made of this material; soft contact lenses are often made of a related polymer, in which acrylate monomers are used that contain one or more hydroxyl groups to make them hydrophilic.

It is a rigid, transparent material and better at transmitting light than inorganic glass. PMMA is more transparent than glass. When glass windows are made too thick, they become difficult to see through. But PMMA windows can be made as much as 13 inches (33 cm) thick, and they're still perfectly transparent. This makes PMMA ideal in the construction of large aquariums where windows must be thick in order to withstand the pressure of millions of gallons of water. The material is often used in place of glass. These optical qualities are the basis for its principal applications: from building to furniture, road signs, the car industry, navy, electrical appliances, laboratory equipment. Unlike glass, PMMA does not filter UV light. Some manufacturers coat their PMMA with UV films to add this property. Up to wavelengths of 2800 nm, PMMA allows most IR (infrared) light to pass. Longer wavelengths of IR energy, up to 25,000 nm are essentially blocked. Special formulations of colored PMMA exist to allow specific IR wavelengths to pass while blocking visible light (for remote control or heat sensor applications, for example). PMMA can be joined using cyanoacrylate cement (so-called "Superglue"), or by using liquid dichloromethane to dissolve the plastic at the join which then fuses and sets, forming an almost invisible weld. PMMA can also be easily polished, by which method cut edges (which turn opaque) can be returned to transparency.

In orthopedics, PMMA bone cement is used to affix implants and to remodel lost bone. It is supplied as a powder and a liquid; when mixed, they yield a dough which then hardens. Dentures are often made of PMMA. In cosmetic surgery, tiny PMMA microspheres suspended in some biological fluid are injected under the skin to permanently reduce wrinkles or scars.

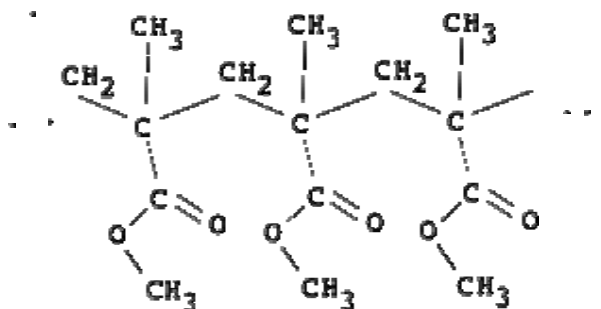

#### 4.6 POLYCARBONATE

It is an amorphous engineering thermoplastic with excellent combination of properties. It is one of the engineering plastic to compete with die cast metals. Polycarbonate, or specifically polycarbonate of bisphenol A, is a clear plastic used to make shatterproof windows, lightweight eyeglass lenses

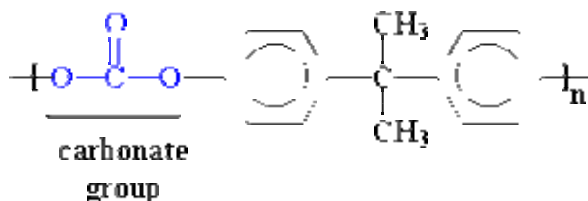

Polycarbonate of bisphenol A is a thermoplastic. This means it can be molded when it is hot. But the polycarbonate used in eye glasses is a thermoset. Polycarbonate plastic is used to make bullet-proof windows, greenhouse walls, automobile headlamps, and rugged housings for cell phones, pagers, and laptop computers. It is a tough, shatter- and heat-resistant material, and is now being used in as many aesthetic applications as in traditional functional applications. From fashionable designer houseware to eye-catching transparent housing for electronics, polycarbonate plastic has bridged the gap between functionality and style. It has become sought after not only for its outstanding physical properties, but also for its ability to be molded into amazingly intricate shapes and dyed with an imagination's worth of brilliant and transparent colors. Like new clothing material that takes the catwalks of Milan by storm, polycarbonate plastic has become fashionable-it has become chic.

Polycarbonate is a tough, dimensionally stable, transparent thermoplastic that has many applications which demand high performance properties. This versatile thermoplastic maintains its properties over a wide range of temperatures, from -40°F to 280°F. It is available in three types: machine grade; window and glass-filled. It has the highest impact of any Thermoplastic, transparent up to 2" in special grades, outstanding dimensional and thermal stability, and exceptional machinability, stain resistant and non-toxic with low water absorption. Machine Grade is relatively stress free to permit the most demanding machining. It is also available in glass-filled. This polycarbonate is perfect for high performance uses in tough applications over a broad temperature range. Window Grade is optically clear, providing total luminous transmittance and very low haze factor. The high impact strength makes it resistant to repeated blows, shattering and spalling. Polycarbonate is excellent for electrical applications, because of its high dielectric strength and high volume resistivity which decreases only slightly as temperature or humidity is increased

Polycarbonate is unusually tough, due to the nature of its chemical bonding. It is also transparent and almost self extinguishing, with a relatively high continuous use temperature of around 115°C. Chemical resistance is not outstanding and it needs the addition of light stabilizers for any UV resistance. Glass fibers enhance the stiffness but reduce toughness, as might be anticipated. Polycarbonate is a versatile blending material, with blends of PC/PET and PC/ABS available commercially. Applications of polycarbonate include: glazing panels, light fittings, safety helmets and medical components.

### Glass Filled

Glass-reinforced polycarbonate is finding principal applications in designs where metals, particularly die-cast aluminum and zinc, are commonly used. The coefficient of thermal expansion is reduced by nearly 75%, thus equaling that of some metals. While glass-reinforced has less impact strength than standard grades, it is still tougher and more impact resistant than most other plastics and die cast aluminum.

### Machinability

Parts can be easily machined from standard metal working tools. No special tools are needed, and finished parts can be polished to a high gloss. Water or water-soluble cutting oils should be used when machining polycarbonate, since some standard cutting oils will attack the material. Polycarbonate can be machined on standard metalworking or woodworking equipment. Its unique properties permit it to be machined without chipping, splitting or breaking.

### Annealing

Polycarbonate slab (Zelux) has been stressed relieved using Liquo-Temp annealing process. In some instances where extensive machining is required, a secondary annealing of semi-finished parts is highly recommended. Secondary annealing can be accomplished by heating parts at 250°F in a desiccated air circulating oven for one hour per one inch of thickness. After heating, the oven should be turned off and allowed to cool to room temperature spontaneously.

### Bonding

Polycarbonate can be mechanically bonded by standard methods. It can also be cemented by using a solvent such as methylene chloride or adhesives such as epoxy, urethane and silicone. Polycarbonate can also be ultrasonically or vibrationally welded.

### Applications Appliances

Coffee filters, shaver housings, chocolate moulds, blenders, table wares, kitchen mixer bowls, grinder bowls, housings for ball point and fountain pens, rim heater grills, motor bracket and housing, camera, binocular casings and parts, flash lights, lenses and casings, water tank for steam iron, fruit juicer parts, high impact vacuum sweeper housings, mixers and power tools, bobbins for textile industries, baby feeding bottles and cutlery. Automotive Wind screen wiper brackets, car interior moulded trims, instrument glazing, indicator lamps, wind shield for two wheelers, door handles, head lamp support, traffic light housings and signal lenses, battery cases, helmets, wheel cover, body panels, components for sewing machine, chassis, levers, valves, control cams, directional signs, ventilation and radiator grills, housing for automobile and aerial motors etc.

### Electrical & electronics

Wiring devices, insulator panels, plug and socket terminal blocks, coil formers, starter enclosures, electric meter covers, breaker boxes, gears, fuses, telephone housing for mining operations, dials, sight windows, housing for computers, calculators, magnetic disk packs etc. Food contact articles Mineral water bottles, microwave oven wares, food storage containers etc

### Medical equipment components

Blood bottles, dispensers for inhalers, sterilisable lab wares and containers, tissue culture dishes, surgical disposables, diagnostic cardio-vascular and intravenous devices, housing for blood cleaning filters

### Other uses

High temperature and pressure windows , face shields , industrial equipment and housing components, instrument components, electrical insulators and connectors, aircraft & missile components, portholes in pressure chambers, jet pump impellers and diffusers, card guides, assembly line cogs, sporting goods, slide rule components vacuum metallised reflectors, housing for street lamps, lenses and safety glasses, sun glasses, face protective wares audio compact discs, film and slide cassettes,(the astronauts stepped onto the moon in polycarbonate helmets), windows, bank screens, police shields etc.

### Typical physical properties

Specific gravity : 1.2,

Tensile strength MPa : 62,

Tensile modulus MPa : 2379,

Flexural modulus MPa : 2344,

Elongation at break (%): 110,

Impact strength izod, notched, J/m : 123,

Hardness : M70,

Deflection temperature under load (1.82 MPa): 132°C,

Coefficient of linear expansion( mm/mm/°C)  $122 \times 10^{-6}$ ,

Water absorption 24 hrs (%) : 0.15,

Refractive index: 1.58-

1.59, Dielectric strength (KV/mm): 15

Dielectric constant ( $10^6$  Hz): 2.97,

Power factor: 0.0021,

Volume resistivity( Ohm.m):  $2.1 \times 10^{16}$ ,

Melting point,( °C): 220-230,

Glass transition temperature (°C): 140,

Mould shrinkage( %): 0.4 - 0.7.

### 4.8 ABS Plastics

It is a tercopolymer containing styrene, acrylonitrile and butadiene comonomers. The earliest materials were the physical blends of styrene-acrylonitrile copolymer(SAN) and acrylonitrile- butadiene copolymers. Today the ABS refers to a product consisting of discrete cross-linked polybutadiene rubber particles that are grafted with SAN and embedded in a SAN matrix. ABS materials are important for their wide spread use as quality housings for equipments. It possesses the following important properties such as, high impact resistance, good stiffness, excellent surface quality, high dimensional stability at elevated temperatures & good heat distortion temperature, good chemical and stress cracking resistance, good low temperature properties etc. It can be electroplated. Even though polypropylene is cheaper than ABS, ABS is preferred where the extreme toughness and superior heat distortion resistance is required. But its main disadvantages are

i) lack transparency,

ii) poor weathering resistance and iii) poor flame resistance

ABS is used in vehicle construction industry(automotive instrument panels, and other interior components such as fascia panels, door covers, door handles, radiator grilles, ventilation system components, heater housings, seat belt fastenings, console panels, loud speaker housings, interior trim and other uses). ABS is also alloyed with polycarbonate to have enhanced heat resistance and surface hardness in conjunction with good impact strength. Molded ABS products are used in both protective and decorative applications. Examples include safety helmets, camper tops, pipe fittings, home-security devices and housings for small appliances, communications equipment, and business machines. Chrome-plated ABS has replaced die-cast metals in plumbing hardware and automobile grilles, wheel covers, and mirror housings. Typical products vacuum-formed from extruded ABS sheet are refrigerator liners, luggage shells, tote trays, mower shrouds, boat hulls, and large components for recreational vehicles. Extruded shapes include weather seals, glass beading, refrigerator breaker strips, conduit, and pipe for drain-waste-vent (DWV) systems. Pipe and fittings comprise one of the largest single application areas for ABS.

Based on the property requirement ABS can be categorized into different grades such as General purpose , Fire retardant, Improved heat resistant, Enhanced chemical resistant, static dissipation grade, Extrusion grade, Fire retardant-extrusion etc. ABS is more hygroscopic than polystyrene and absorbs moisture upto 0.3%. It can be processed at 250-260°C. It has low heat resistance compared to polystyrene. It is an amorphous material and show low moulding shrinkage. ABS resins are hard, rigid, and tough, even at low temperatures. They consist of particles of a rubberlike toughener suspended in a continuous phase of styrene-acrylonitrile (SAN) copolymer. Various grades of these amorphous, medium-priced thermoplastics are available offering different levels of impact strength, heat resistance, flame retardance, and platability. Most natural ABS resins are translucent to opaque, and they can be pigmented to almost any color. Grades are available for injection molding, extrusion, blow molding, foam molding, and thermoforming. Molding and extrusion grades provide surface finishes ranging from satin to high gloss. Some ABS grades are designed specifically for electroplating. Their molecular structure is such that the plating process is rapid, easily controlled, and economical.

Compounding of some ABS grades with other resins produces special properties. For example, ABS is alloyed with polycarbonate to provide a better balance of heat resistance and impact properties at an intermediate cost. Deflection temperature is improved by the polycarbonate; molding ease, by the ABS. Other ABS resins are used to modify rigid PVC for use in pipe, sheeting, and molded parts. Reinforced grades containing glass fibers, to 40%, are also available.

#### *Properties:*

ABS plastics offer a good balance of tensile strength, impact and abrasion resistance, dimensional stability, surface hardness, rigidity, heat resistance, low-temperature properties, chemical resistance, and electrical characteristics. These materials yield plastically at high stresses,

so ultimate elongation is seldom significant in design; a part usually can be bent beyond its elastic limit without breaking, although it does stress-whiten. While not generally considered flexible, ABS parts have enough spring to accommodate snap-fit assembly requirements.

Impact properties of ABS are exceptionally good at room temperature and, with special



grades, at temperatures as low as  $-40^{\circ}\text{F}$ . Because of its plastic yield at high strain rates, impact failure of ABS is ductile rather than brittle. A long-term tensile design stress of 1,000 to 1,500 psi (at  $73^{\circ}\text{F}$ ) is recommended for most grades.

General-purpose ABS grades may be adequate for some outdoor applications, but prolonged exposure to sunlight causes color change and reduces surface gloss, impact strength, and ductility. Less affected are tensile strength, flexural strength, hardness, and elastic modulus. Pigmenting the resins black, laminating with opaque acrylic sheet, and applying certain coating systems provide weathering resistance. For maximum color and gloss retention, a compatible coating of opaque, weather-resistant polyurethane can be used on molded parts. For weather able sheet applications, ABS resins can be coextruded with a compatible weather-resistant polymer on the outside surface.

ABS resins are stable in warm environments and can be decorated with durable coatings that require baking at temperatures to  $160^{\circ}\text{F}$  for 30 to 60 min. Heat-resistant grades can be used for short periods at temperatures to  $230^{\circ}\text{F}$  in light load applications. Low moisture absorption contributes to the dimensional stability of molded ABS parts.. Molded ABS parts are almost completely unaffected by water, salts, most inorganic acids, food acids, and alkalies, but much depends on time, temperature, and especially stress level. FDA acceptance depends to some extent on the pigmentation system used. The resins are soluble in esters and ketones, and they soften or swell in some chlorinated hydrocarbons, aromatics, and aldehydes.

#### POLY ETHER ETHER KETONE(PEEK)

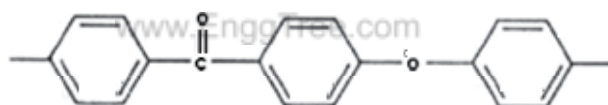

Figure 1. Chemical formula of polyether ether ketone (PEEK) from I.C.I.

PEEK ( $T_g : 145^{\circ}\text{C}$ ) is an abbreviation for PolyEtherEther-Ketone, a high performance engineering thermoplastic and is an excellent material for a wide spectrum of applications where thermal, chemical, and combustion properties are critical to performance. The tensile properties of PEEK™ exceed those of most engineering plastics and can be reinforced with carbon fiber resulting in a tensile strength of over 29,000 psi (200 MPa) with excellent properties being retained up to  $570^{\circ}\text{F}$ ( $300^{\circ}\text{C}$ ). The exceptional stiffness of PEEK™ is reflected in its flexural modulus which is among the best of any thermoplastic. Glass or carbon fiber reinforcement gives further improvement up to very high temperatures.

These semi-crystalline polymers have excellent mechanical properties, good thermal stability and good chemical resistance. Despite a  $T_g$  of  $145^{\circ}\text{C}$ , the continuous service rating of PEEK is  $250^{\circ}\text{C}$ . PEEK is inherently fire retardant. It is easier to burn a hole through an aluminium sheet than through one made from PEEK. These materials are, however, very expensive and difficult to process. They find application in high temperature wire covering and printed circuit boards. Fibre reinforced grades are used in demanding applications that include valves, pumps and missile nose cones

PEEK combines excellent tribological properties with moldability and outstanding performance at high temperatures. Carbon fiber-reinforced PEEK is probably the only injection moldable bearing material that has a measurable wear factor at over 500°F (260°C), all the thermoplastics fail at or below this temperature. PEEK can retain its flexural and tensile properties at very high temperatures -- in excess of 250°C (482°F). The addition of glass fiber and carbon fiber reinforcements enhances the mechanical and thermal properties of the basic PEEK material. Superior chemical resistance has allowed them to work effectively as a metal replacement in harsh environments. They are inert to all common solvents and resist a wide range of organic and inorganic liquids. When extensive machining is required, a secondary annealing process should be considered.

## MECHANICAL

At room temperature, PEEK™ functions as a typical engineering thermoplastic. It is tough, strong, rigid, has good load bearing properties over long periods, and it is resistance to both abrasion and dynamic fatigue.

## THERMAL

PEEK™'S continuous service UV rating is 482°F (250°C) for unfilled and 500°F (260°C) for glass filled grades. PEEK™ also offers high temperature mechanical properties making it suitable for some application up to 600°F (315°C).

## FLAMMABILITY

PEEK™ has a high "Oxygen Index" and meets UL 94 -VO requirements, and demonstrates extremely low smoke emission. It contains no flame-retardant additives or halogens.

## CHEMICAL RESISTANCE

PEEK™ has good resistance to aqueous reagents and long-term performance in superheated water at 500°F. (260°C.). Its resistance to attack is good over a wide pH range from 60% sulfuric acid to 40% sodium hydroxide at elevated temperatures. Attack can occur with some concentrated acids.

## HYDROLYSIS RESISTANCE

PEEK can be used for thousands of hours at temperatures in excess of 480°F(250°C). in steam or high-pressure water environments without significant degradation in properties.

## RADIATION RESISTANCE

Preliminary tests suggest that radiation resistance is extremely good.

Two of the highest performance areas of PEEK are in oil exploration and chemical processing industry.

### Oil Exploration

Geologists use data logging equipment to analyze the nature and structure of rock in an

attempt to locate oil bearing strata. This may involve sample removal or the use of a probe (acoustic, radiation, electrical) to evaluate the rock. Although all downhole materials must have good wear resistance and mechanical strength, the specific geometries involved and the function of the probe exclude most conventional materials. Therefore, an easily processable material which can withstand temperatures in excess of 392°F (200°C), pressures up to 580 psi, and has excellent resistance to chemically aggressive environments, electricity and radiation is required. Natural PEEK™ polymer and GL30 PEEK™ polymer composite grades are chosen by the oil industry as they are the only materials able to perform well in such a demanding environment.

The GL30 PEEK™ polymer is specially formulated to contain an optimum amount of short glass fiber reinforcement. The mechanical properties of the material are greatly enhanced with little reduction in processability.

### Chemical Processing Industry

PEEK polymer composites are becoming increasingly used in the chemical processing industry due to a combination of excellent mechanical properties, processability, a high continuous operating temperature (500°F (260°C), UL746B) and outstanding chemical resistance. Conventional processing methods (injection molding, compression molding) are often used to form compressor plates, seals and pump components used in gas and fluid transport systems. The excellent fatigue resistance and general mechanical properties have been shown to outperform fluoropolymers, while the chemical resistance is vastly superior to metal components for such applications. The ability to form thin films on complex 3-dimensional objects means that PEEK™ polymer is often used to coat metallic parts which operate in chemically aggressive environments. The formation of these thin films is achieved by either electrostatic or plasma spray coating techniques. The chemical processing industry strives for purity of product. The contamination introduced by materials used to handle the substances during production is a selection criteria. PEEK™ polymer is inherently pure, and therefore can be used in long service applications with extremely low levels of contamination introduced to the chemical streams being processed.

### PEEK Polymer for the Automotive Industry

The automotive industry constantly strives to increase the performance level and minimize the weight of in-engine components. Therefore, thermoplastic materials are often used to replace parts of the engine which are traditionally constructed from metals. PEEK™ polymer, a polyaryletherketone resin, is the leading high performance thermoplastic for automotive applications. It combines outstanding tribological performance with excellent mechanical properties over a wide temperature range.

Most automotive applications are required to operate at temperatures in excess of 248°F (120°C). Therefore, a high continuous operating temperature (500°F (260°C), UL746B) and excellent mechanical properties at this temperature make PEEK™ polymer the natural choice

Tribological performance may be defined as the friction and wear of interacting surfaces in relative motion. Therefore, the tribology of dry and lubricated contacts is critical for the operation of internal combustion engines. PEEK™ polymer has excellent friction and wear properties which are optimized in the specially formulated tribological grades, namely, 450FC30 and 150FC30 PEEK™ polymer.

## ADVANTAGES OF PEEK

Excellent flexural, impact and tensile characteristics. Very high continuous working temperature.

PEEK's excellent mechanical properties are retained even at temperatures in excess of 250°C (482°F).

Very high heat distortion temperature.

For unreinforced PEEK, the HDT is 160°C (320°F). The addition of 30% glass or carbon fiber reinforcement results in a dramatic increase to 315°C (599°F).

Exceptional chemical resistance.

PEEK is insoluble in all common solvents and, being crystalline, is extremely resistant to attack by a very wide range of organic and inorganic chemicals. A superior dielectric with low loss even at high temperatures and frequencies.

Excellent hydrolysis resistance.

PEEK has an excellent resistance to hydrolysis in boiling water and superheated steam (sterilization/ autoclavability) at temperatures in excess of 250°C (482°F).

Good radiation resistance.

Absorbing more than 1000 Mrads of irradiation with no significant reduction in mechanical properties, PEEK exhibits exceptional resistance to high doses of gamma radiation.

Outstanding wear and abrasion resistance.

PEEK and reinforced PEEK have excellent wear and abrasion resistance characteristics with low coefficient of friction and high limiting PV properties.

Low smoke and toxic gas emissions.

Levels of smoke and toxic gas released during combustion are among the lowest of any thermoplastic material.

## APPLICATIONS

PEEK's exceptional property profile enables it to be utilized in many of the most critical areas in general industry, such as, automotive, marine, oilwell, electronics, medical, aerospace etc

Key physical properties

ASTM or UL test	Property	Value

D792	Density (lb/in <sup>3</sup> ) (g/cm <sup>3</sup> )	0.047 1.31
D570	Water Absorption, 24 hrs (%)	0.10
D638	Tensile Strength (psi)	16,000
D638	Tensile Modulus (psi)	500,000
D638	Tensile Elongation at Break (%)	20
D790	Flexural Strength (psi)	25,000
D790	Flexural Modulus (psi)	600,000
D695	Compressive Strength (psi)	20,000
D695	Compressive Modulus (psi)	500,000
D785	Hardness, Rockwell	M100
D256	IZOD Impact Notched (ft-lb/in)	1.0
D696	Coefficient of Linear Thermal Expansion (x 10 <sup>-5</sup> in./in./°F)	2.6
D648	Heat Deflection Temp (°F / °C) at 264 psi	320 / 160
D3418	Melting Temp (°F / °C)	644 / 340
-	Max Operating Temp (°F / °C)	480 / 249
C177	Thermal Conductivity (BTU- in/ft <sup>2</sup> -hr-°F) (x 10 <sup>-4</sup> cal/cm-sec-°C)	1.75 6.03

UL94	Flammability Rating	V-0
D149	Dielectric Strength (V/mil) short time, 1/8" thick	480
D150	Dielectric Constant at 1 MHz	3.30
D150	Dissipation Factor at 1 MHz	0.003
D257	Volume Resistivity (ohm-cm) at 50% RH	4.9 x 10 <sup>16</sup>

For hostile environments, PEEK is a high strength alternative to fluoropolymers. PEEK carries a V-0 flammability rating and exhibits very low smoke and toxic gas emission when exposed to flame. And unfilled PEEK is approved by the FDA for food contact applications. PEEK is inherently fire retardant. It is easier to burn a hole through an aluminium sheet than through one made from PEEK. These materials are, however, very expensive and difficult to process. They find application in high temperature wire covering and printed circuit boards. Fibre reinforced grades are used in demanding applications that include valves, pumps and missile nose cones.

#### FEATURES

- Excellent chemical resistance
- Very low moisture absorption
- Inherently good wear

and abrasion resistance • Unaffected by continuous exposure to hot water or steam

#### Polytetrafluoroethylene(PTFE)

Polytetrafluoroethylene [Teflon,  $-(CF_2-CF_2)_n-$ ] is obtained by polymerizing ( emulsion polymereization) tetrafloroethylene (ie., When all the hydrogen atoms in polyethylene have been replaced by fluorine, polytetrafluoroethylene (PTFE) is obtained). It is a tough, flexible, non- resilient material of moderate tensile strength but with excellent resistance to heat, chemicals and to the passage of electric current. It is resistant to many chemicals, including acetic acid, ammonia, sulfuric acid, and hydrochloric acid It remains ductile in compression at temperatures as low as 4K(- 269°C). The coefficient of friction is low and is reported to be lower than that of any other solid. PTFE is an outstanding insulator over a wide range of temperature and frequency. Its volume resistivity exceeds  $10^{20}$  ohm meter. Any current measured is a polarization current rather than a conduction current. It has a low dielectric constant (2.1 at 60 Hz). A melt viscosity of  $10^{10}$ - $10^{11}$  poises has been measured at about 350°C. A slow rate of decomposition has been detected at the melting point and this increases with increase in temperature. There are no solvent for PTFE and it is attacked by molten alkali metal at room temperature and in some cases by fluorine. Treatment with solution of sodium metal in liquid ammonia will sufficiently alter the surface of PTFE so that it can be cemented to other materials using epoxy adhesives. Although it has good weathering resistance, it is degraded by high energy radiation. The polymer is not wetted by water and does not absorb measurably. The permeability to gases is very low and water vapour transmission is only half that of low density polyethylene.

It has a high bulk density and exceptional chemical properties.. It can temporarily withstand temperatures of 260°C and still have the same chemical properties. Teflon also retains its chemical properties in cryogenic temperatures of -240°C . It is a chemical inert material, making it relatively safe to use and handle. It has an initial melting point of 342 +- 10 °C and a secondary melting point of 327 +- 10°C . Teflon has a low coefficient of friction, and is oleophobic (resistant to oil) and hydrophobic, making it useful in cookware. This property of a non-wetting surface to both oils and water comes from Teflon being a polytetrafluoroethylene, which has an ultra low surface energy value of 18.6 Newtons per meter squared. Teflon has a high dielectric strength over many different frequencies, a low dissipation factor, and a high surface resistivity. The electroconductivity can be increased high enough to allow Teflon to be used as an anti-static coating. Teflon possesses outstanding optical clarity and transmission. Teflon® AF has outstanding light transmission from the deep UV range out through and including a significant portion of the IR range. Also, because it does not absorb light, Teflon® AF will not deteriorate with exposure to light. These optical properties, over such a wide range of wavelength and possible exposure conditions, are unmatched by any other polymer. PTFE is a tough, flexible, crystalline polymer that retains ductility down to -150°C. Its solvent and chemical resistance is the best of all the thermoplastics and it has the lowest coefficient of friction of any known solid (0.02). On the downside, it has to be moulded by a powder sintering technique, although it can be extruded very slowly, and it is very expensive with low strength and stiffness. Applications of PTFE are therefore limited to those that make use of its special properties, for example, bearings, chemical vessel linings, gaskets and non-stick coatings.

Teflon has the lowest known dielectric constant of any plastic material. It exhibits excellent mechanical and physical properties at end-use temperatures up to 300°C It has good dimensional stability, reduced mold shrinkage, a smooth surface, and rigidity at high-

use temperatures. Teflon is used for gasket and packaging materials in chemical processing equipment, as electrical insulation, as bearings, seals, and piston rings in mechanical applications, especially those requiring anti-stick characteristics. In addition to chemical, heat, corrosion, and impact resistance. Teflon is weather resistant, flexible, non-flammable, etc. Ionized oxygen in oxygen plasma is often sufficiently energetic to react with the polymer chain. Electron bombardment at the megarad level can sever the polymer chain. Techniques for molding polytetrafluoroethylene resemble those of powder metallurgy or ceramics rather than those of polymer fabrication. It may be extruded in a ram or screw extruder. The high degree of cohesion between cold pressed particles of PTFE is utilized in a calendering process for making tape and coating wire.

### Nonpolarity

The carbon backbone of the linear polymer is completely sheathed by the electron cloud of fluorine atoms, much like a wire core is protected by insulation coating. This ensheathment, and the angles at which the carbon-fluorine bonds are disposed, causes the centers of electronegativity and electropositivity to be perfectly balanced across the polymer chain cross section. As a result, no net charge difference prevails. This nonpolarity of the polymer is partly responsible for its lack of chemical reactivity.

### Low interchain forces

The bond forces between two adjacent polymer chains are significantly lower than the forces within one chain. High C-F and C-C bond strengths are among the strongest in single bond organic chemistry. The polymer must absorb considerable energy to disrupt these bonds. Chemical reactions represent a kinetic and thermodynamic resolution of bond-making and bond-breaking in favor of the most stable system. These bond strengths are hard to overcome. Hence possesses good thermal stability.

### Crystallinity

The high degree of crystallinity in these semicrystalline polymers results in high melting points(327°C), mechanical properties, and an integral barrier to migrating, small, nonpolar molecules. Under certain conditions, these molecules penetrate the plastics. The melting point of Teflon PTFE is one of the highest in organic polymer chemistry.

### Insolubility

There is no known solvent for Teflon fluorocarbon resins under ordinary conditions.

### Low coefficient of friction

The low coefficient of friction of Teflon results from low interfacial forces between its surface and another material and the comparatively low force to deform.

Low dielectric constant and dissipation factor: Teflon provides low, if not the lowest, values for these parameters. These low values arise from the polymer's nonpolarity as well as the tight electron hold in the ultrapolymer bonds.

### Low water absorptivity

For Teflon to absorb water, the surface must remain wet for a long enough time for water to become physico-chemically associated with the polymer chains, and then it must

become included in the polymer bulk structure. Water is a very high energy material and Teflon has a very low surface energy. Therefore, these events are energetically incompatible and only occur under special circumstances and to a small extent.

Excellent weatherability

Weather includes light of various wavelengths (IR, visible, UV), water (liquid or gas), other gases, and normal temperatures and pressure. The physical and chemical makeup of Teflon makes it inert to these influences.

Flame resistant

Teflon will burn when exposed to flame, but will not continue to burn when the flame is removed.

#### 4.7 Polyamides(NYLONS)

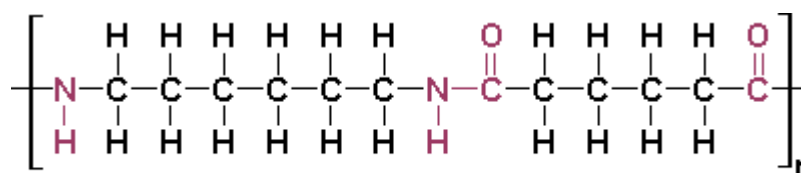

the repeat unit of nylon 6-6

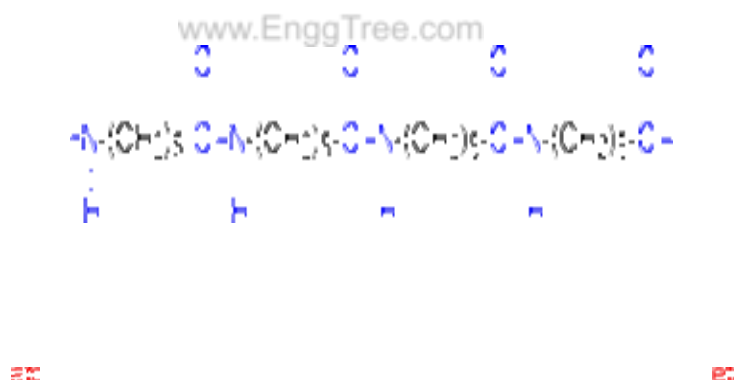

#### Nylon-6

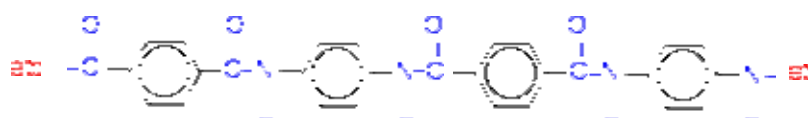

Polyamides are a group of thermoplastic polymers containing amide groups in the main chain. They are popularly known as nylons. They may be aliphatic (nylon 66, nylon 6 etc) or aromatic( Kevlar, nomex etc). Commercially important polyamides are PA-66, PA-6, PA-11, PA-12, PA-610, PA-612 etc. Polyamides have good strength and toughness with excellent fatigue resistance. However, they are prone to absorb moisture, ranging from 8 - 10% for PA6 and PA66 to 2 - 3% for PA11 and PA12 at saturation. Mechanical properties



are affected by moisture, with toughness improving with the absorption of moisture whereas modulus is reduced. Polyamides are resistant to hydrocarbons, esters and glycols, but swell and dissolve in alcohols. They are also attacked by acids but generally stable to alkalis. PA6 and PA66 are mainly used in textiles, but they also find application where toughness is a requirement, for example, zip fastener teeth, gears, wheels and fan blades. PA11 is more flexible than PA66 and is typically used for petrol and hydraulic hose as well as powder coatings for metals. Strength and rigidity of these materials can be dramatically enhanced by the addition of glass or carbon fibre reinforcement; the level of saturation water absorption is also reduced. However, the designer needs to be aware of the anisotropic properties that can result in mouldings due to the flow and alignment of the reinforcing phase that occurs during moulding.

*Polyamides* are fairly readily attacked by strong acids, but are much more resistant to alkaline hydrolysis. Hydrolysis is faster at higher temperatures. Hydrolysis by water alone is so slow as to be completely unimportant. Kevlar is rather more resistant to hydrolysis than nylon .

### Properties

Hard and tough thermoplastic, good abrasion resistance, low coefficient of friction, high tensile strength, good dimensional stability, low tendency to warp, smooth appearance of surface, average to high surface gloss, resistant to lubricants, engine fuels, grease etc, good resistance to coolants, refrigerants, paint solvent cleaners, resistant to aqueous solution of many inorganic chemicals.

### Uses

[www.EnggTree.com](http://www.EnggTree.com)

Nylon fibres are used in textiles, fishing line and carpets. Nylon films is used for food packaging, offering toughness and low gas permeability, and coupled with its temperature resistance, for boil- in-the-bag food packaging. Moulding and extrusion compounds find many applications as replacements for metal parts, for instance in car engine components. Intake manifolds in nylon are tough, corrosion resistant, lighter and cheaper than aluminium (once tooling costs are covered) and offer better air flow due to a smooth internal bore instead of a rough cast one. Its self-lubricating properties make it useful for gears and bearings.

Electrical insulation, corrosion resistance and toughness make nylon a good choice for high load parts in electrical applications as insulators, switch housings and the ubiquitous cable ties. Another major application is for power tool housings. Glass reinforced polyamides are the material of choice for applications such as power tool housings. Transparent amorphous polyamides are available and find application in sterilisable medical components and sight glasses.

### 4.5 Polyethylene terephthalate(PET)

Polyethylene terephthalate (PET) and polybutylene terephthalate (PBT) are the most common thermoplastic polyesters. They are similar to PA6 and PA66 in many respects but with much lower water absorption. However, they are prone to hydrolysis, and prolonged contact with water at temperatures as low as 50°C has a detrimental effect on properties. Polyethylene terephthalate (PET) is often called just “polyester”. Polybutylene terephthalate (PBT) also a (thermoplastic) polyester, the most common resin system used

in glass reinforced plastic ( GRP) is also a polyester system.

### General Properties

Polyethylene terephthalate (PET) is a hard, stiff, strong, dimensionally stable material that absorbs very little water. It has good gas barrier properties and good chemical resistance except to alkalis (which hydrolyse it). Its crystallinity varies from amorphous to fairly high crystalline. It can be highly transparent and colourless but thicker sections are usually opaque and off-white.

### Polyethylene Terephthalate Films

It is widely known in the form of biaxially oriented and thermally stabilised films usually referred to by their main brand names Mylar, Melinex or Hostaphan. Strictly speaking, these names should be used only for this type of film whose properties are different from, and in several respects superior to, those of “ordinary” polyethylene terephthalate (PET) film(Mylar)

### Applications

The “Mylar®-type” films are used for capacitors, graphics, film base and recording tapes etc. PET is also used for fibres for a very wide range of textile and industrial uses (Dacron®, Trevira®, Terylene®). Other applications include bottles and electrical components.

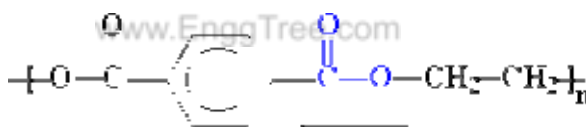

ester

group

Its melting and glass transition temperature are 265°C and 74°C respectively. PET is used in the manufacture of biaxially oriented film and bottles, the latter suitable for carbonated drinks. The purpose of the orientation is to enhance rigidity, strength and toughness and also to improve barrier properties, which allows thinner bottles to be made.

PBT displays a good combination of stiffness and toughness and can withstand continuous service at 120°C. The most important grades are those reinforced with glass. Applications for PBT include electrical connectors, pump components, and gears, as well as under bonnet and exterior parts for cars.

### Thermoplastic Polyimides (PI, PAI, PEI) Polyimide( Vespel-Dupont)(PI)

Polymeric compounds containing multiple imides, ie, NH groups derived from ammonia (NH<sub>3</sub>) by replacement of two hydrogen atoms by metals or equivalents of acid groups.

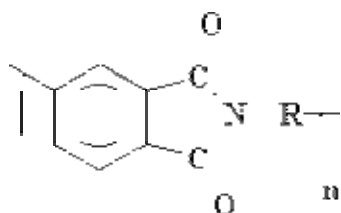
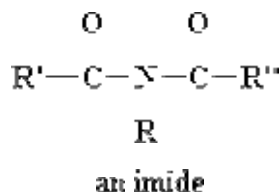

aromatic heterocyclic polyimide

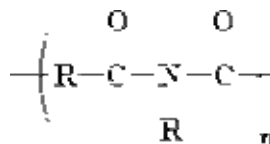

linear polyimide

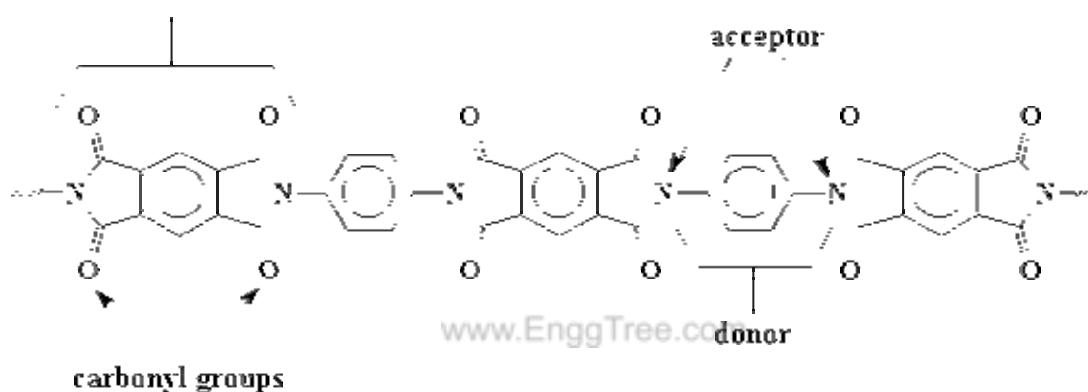

Polyimides (PI) are noted for their high temperature performance, retaining their mechanical properties to 250°C. They exhibit low flammability and smoke emission characteristics and offer the lowest minimum service temperature of thermoplastics. They are relatively expensive and can be difficult to process. Thermoplastic polyimide requires high temperatures and pressures and is usually processed by autoclave or compression moulding. They are susceptible to attack by halogenated solvents

Polyimides are a very interesting group of incredibly strong and astoundingly heat and chemical resistant polymers. Their strength and heat and chemical resistance are so great that these materials often replace glass and metals, such as steel, in many demanding industrial applications. Polyimides are even used in many everyday applications. They are used for the struts and chassis in some cars as well as some parts under-the-hood because they can withstand the intense heat and corrosive lubricants, fuels, and coolants cars require. They are also used in the construction of many appliances as well as microwave cookware and food packaging because of their thermal stability, resistance to oils, greases, and fats and their transparency to microwave radiation. They can also be used in circuit boards, insulation, fibers for protective clothing, composites, and adhesives. These polymers have excellent resistant to oxidative degradation, chemicals, strong bases and

high energy radiation. It possesses good flame and abrasion resistances. But unfortunately these polymers cannot be moulded by conventional thermoplastic techniques. They are used as wire enamels, insulating varnishes, as coatings for glass cloth etc. Polyimide foams have been used for sound deadening of jet engines. They are used in space craft construction, rockets and weapons technology. These polymers consists predominantly of ring structures and hence possesses high softening point. They are used in the manufacture of seals, gaskets, piston rings and as a binder in the diamond grinding wheels. Glass and carbon fibre reinforced polyimides are used in aircraft industry. It is also used in soldering and welding equipments. Kapton is a polyimide film made from pyromellitic anhydride and aromatic ether amine. Polyesterimides and polybismaleinimides are modified polyimides.

#### Polyamide- imide ( PAI)

Polyamide-imides are amorphous thermoplastic materials with excellent mechanical properties, especially at elevated temperatures. Trimellitic anhydrides react with aromatic diamines to produce polyamide-imides. Polyamide-imides are applied in demanding engineering applications. Solvay Advanced Polymer's Torlon® is a well-known example of a polyamide-imide engineering resin that is also used to molded, extruded or machined plastic parts or shape stock.

Polyamide-imides are thermoplastic amorphous polymers which enjoy exceptional mechanical, thermal and chemical resistant properties. These properties put polyamide-imides at the top of the price and performance pyramid. Other high performance polymers in this same realm are polyetheretherketones and polyimides. Polyamide-imides hold, as the name suggests, a positive synergy of properties from both polyamides and polyimides, such as high strength, melt processability, exceptional high heat capability, and broad chemical resistance. Polyamide-imide polymers can be processed into a wide variety of forms, -from injection or compression molded parts and ingots, -to coatings, films, fibers and adhesives. Properties approaching those of Polyimide, yet melt processable. Highest strength of any unreinforced thermoplastic. Good wear resistance. Low smoke emission. Good radiation resistance

#### Typical properties

Density (g/cm <sup>3</sup> )	1.40
Surface Hardness	RM109
Tensile Strength (MPa)	185
Flexural Modulus (GPa)	4.58
Notched Izod (kJ/m)	0.13
Linear Expansion (/°C x 10 <sup>-5</sup> )	3.6
Elongation at Break (%)	12
Strain at Yield (%)	8
Max. Operating Temp. (°C)	210
Water Absorption (%)	0.28
Oxygen Index (%)	43
Flammability UL94	V0
Volume Resistivity (log ohm.cm)	17
Dielectric Strength (MV/m)	23
Dissipation Factor 1kHz	0.001

Dielectric Constant 1kHz	3.5
HDT @ 0.45 MPa (°C)	260+
HDT @ 1.80 MPa (°C)	274
Material. Drying hrs @ (°C)	16@150
Melting Temp. Range (°C)	315 - 360
Mould Shrinkage (%)	0.7
Mould Temp. Range (°C)	180 - 260

It is used for fabricating valves, pumps bearings, electrical connectors, gears and general mechanical components, Parts for jet engines, internal combustion engines, Printed circuit boards, accessories for refrigeration plants etc. Polyamideimide (PAI) was initially developed as a high temperature enamel but was later modified for processing by injection and compression techniques. No other commercially available unreinforced thermoplastic is as strong as PAI over its operating range. Applications include valves, bearings, gears, electrical connectors, jet engine parts labyrinth seals, car mandrel, bearing cages , etc.

#### Polyetherimides(PEI)

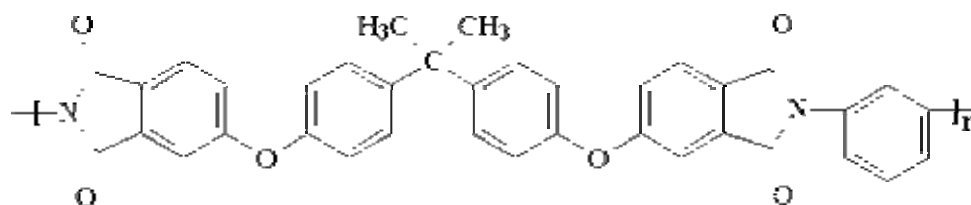

www.EnggTree.com

Polyetherimides are thermally stable at high temperatures and exhibit good optical properties making them useful in high temperature processing applications, in the fabrication of optoelectronics devices, and in optical applications. Polyetherimides (PEI) are amorphous, high performance thermoplastics with a continuous use temperature of around 170° C. PEI resins can also be melt processed using typical equipment for high volume production. The strength, creep and impact properties of PEIs make them ideal for under bonnet components. They are also used in high temperature switchgear and electrical connectors. A number of medical equipment components are manufactured using PEIs, taking advantage of their excellent resistance to repeated sterilisation using steam, autoclave, gamma radiation or ethylene oxide. Microwave cookware is another application. They exhibit very high tensile strength without reinforcement, high glass transition(215°C), deflection(200°C) and softening ( 219°C) temperatures. PEI are competitive with PAI, polysulphones, polycarbonates, polyphenylene sulphides etc. It is used in microwave equipment, printed circuit boards, wire insulation etc.

#### Polyphenylene Oxide (PPO)

PPO is prepared by oxidative coupling of phenylene oxide monomer

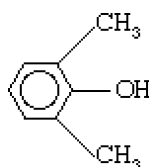

using oxygen and a copper-based catalyst. PPO is a high strength, tough and heat resistant polymer, but in the unmodified state it is extremely difficult to process. It is also relatively expensive. Fortunately, it is miscible with polystyrene, and the resulting amorphous blends are easily processed and cheaper than PPO, with little loss in mechanical properties. Stiffness and strength are approximately 50% higher than high impact ABS, with similar creep behaviour. Modified PPO grades are also self extinguishing when ignited. Resistance to solvents is poor, a characteristic of styrene-based polymers. As well as glass fibre reinforced grades, these materials are available in structural foam grades. Although unmodified polyphenylene oxide (PPO) is a semi-crystalline thermoplastic, all commercially available grades are blended with (high impact) polystyrene in order to improve melt processability. A wide range of proportions, together with the use of other modifiers, results in a good range of grades with differing properties tailored to the needs of individual end-uses. These blends are amorphous, opaque, pale grey engineering thermoplastics with a balance of properties (and cost) not unlike nylon but without nylon's high water absorption and consequent dimensional instability. However they have poor fatigue characteristics and poor solvent, though good hydrolysis, resistance.

### Thermal properties

PPO has a higher heat deformation resistance than many general purpose thermoplastics at a lower price than the more expensive 'engineering thermoplastics'. One of the main reasons for using the PPO blends is the outstanding dimensional stability at elevated temperatures and the broad temperature use range.

### Fire behaviour

Conventional grades are non self-extinguishing but self-extinguishing grades (generally made by including phosphorous based additives) are available with a slightly lower heat distortion temperature and impact strength. As a general rule the materials are difficult to ignite and burn with a sooty luminous flame and a pungent odour but do not drip. The flammability ranges from UL 94 HB to V-0 depending on the grade tested.

### Electrical properties

Moisture absorption is low over a wide range of humidity levels and therefore dielectric properties are excellent over a wide range of moisture and temperature conditions.

### Optical properties

Natural PPO blends are opaque but can easily be coloured a wide range of colours. PPO blends are resistant to acids, alkalis, most salt solutions and alcohols

PPO blends are not resistant to benzene, chlorohydrocarbons, ketones and many halogenated or aromatic hydrocarbons.

Dimensional changes are negligible even in boiling water.

### Weathering resistance:

PPO blends have good weathering resistance when adequately stabilized but uncoloured grades will yellow in UV. Black grades have the best UV resistance.

Stress cracking resistance:

Stress cracking resistance is high for most common solvents at low temperatures. Key

physical properties

Dielectric constant @1MHz	2.7
Dielectric strength ( kV.mm <sup>-1</sup> )	16-20
Dissipation factor @ 1kHz	0.004
Surface resistivity ( Ohm/sq )	2x10 <sup>16</sup>
Volume resistivity ( Ohm.cm )	10 <sup>17</sup>
Abrasive resistance - ASTM D1044 ( mg/1000 cycles )	20
Coefficient of friction	0.35
Elongation at break ( % )	50
Hardness – Rockwell	M78/R115
Izod impact strength ( J.m <sup>-1</sup> )	200
Poisson's ratio	0.38
Tensile modulus ( GPa )	2.5
Tensile strength ( MPa )	55-65
Density ( g.cm <sup>-3</sup> )	1.06
Tensile strength ( MPa )	55-65
Density ( g.cm-3 )	1.06
Flammability	HB
Limiting oxygen index ( % )	20
Resistance to Ultra-violet	Good
Water absorption - over 24 hours ( % )	0.1-0.5
Coefficient of thermal expansion ( x10-6 K-1 )	60
Heat-deflection temperature - 0.45MPa ( °C )	137
Heat-deflection temperature - 1.8MPa ( °C )	125
Lower working temperature ( °C )	-40
Thermal conductivity ( W.m-1.K-1 )	0.22 @ 23
Upper working temperature ( °C )	80-120

Applications include electrical and TV components, washing and dish-washing machine parts, automobile parts (especially fascias) and structural foam. Modified PPOs are used for electrical fittings, car fascia panels, TV components, and computer housings. Foamed modified PPO is particularly suited to the last example. Casings for computers and business machines. Frame and chassis material for large domestic appliances, e.g. Tumble driers, dishwashers and washing machine components. Other large mouldings such as pallets and automotive roofs. Fire retardant PPO is used in electrical industry, especially in radio and televisions, for insert card mountings and coil formers. Fuse boxes, transformers and small motor housings.

The raw PPO polymer has some excellent properties but the price is restrictive and very little of this material is manufactured. The ability of PPO to be blended with polystyrene lead to the introduction in 1966 of the 'Noryl'® family of polymers by General Electric Plastics. This family is sometimes called PPO but in fact is more correctly a blend of PPO

and polystyrene. These types of material have some excellent properties and the price point (more than ABS but less than PC) means that applications are plentiful - especially when some of the excellent properties can be used to their full extent. This polymer data file refers to PPO/PS blends rather than to the raw PPO polymers.

#### Machining

PPO blends can be machined without difficulty using standard machine conditions for polymers. The products are difficult to cut and machining needs to be slow (feeds and speeds).

#### Surface treatment

PPO blends can be painted with good coatability. A primer and a polyurethane type of paint is recommended.

#### Welding

PPO can be solvent welded using commercially available solvents and solvent solutions containing 1 to 7% PPO resin.

#### Bonding

PPO blends can be bonded using a wide range of commercially available adhesives including epoxy adhesives. Mechanical: Machine housings, pump housings and impellers.

#### Applications

Consumer goods: Power tool housings, portable mixers, hairdryers.

Automotive: Instrument panels and seat backs, spoilers, wheel trims, external mirror housings. Electrical: Electrical terminal housings, cable connectors, bulb sockets, coil formers.

Miscellaneous: Plastic parts in central heating systems.

#### Processing

PPO blends generally have excellent processing stability and can be processed on most conventional equipment but the processing temperatures and pressures are sometimes higher than for other polymers. PPO has good dimensional stability and a low mould shrinkage and this allows the production of mouldings and extrusions with close dimensional tolerances. The fibre reinforced grades have an even lower mould shrinkage than the unreinforced grades. Pre-drying is normally only necessary if the granules have been stored under damp conditions or if a high gloss finish is needed. In this case 2 hours at 100°C is generally sufficient.

#### Injection moulding

Typical melt temperatures of 250 to 300°C are needed with a die head temperature of around 250°C for injection moulding of PPO. The injection pressure should be 1000 to 1200 bar and the follow-up pressure should be 50 - 70% of the injection pressure. The back pressure should be set at 30 - 50 bar. The mould temperature should be in the region of 80 to 105°C. Injection speed is generally high but moulds with a long flow path should have adequate mould venting. Mould shrinkage is low (0.005 - 0.01 m/m).



## Extrusion

PPO is relatively easy to extrude and can be processed on single or twin screw extruders and on vented or unvented extruders.

### Polyphenylene sulphide (PPS)

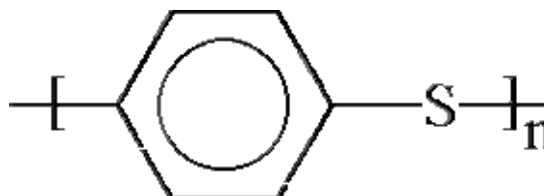

Poly(phenylene sulfide), or PPS, is one of those really high-performance plastics that is very strong and can resist very high temperatures. PPS doesn't melt until around 300 °C. It's also flame resistant. PPS is an *engineering thermoplastics*. PPS is expensive, so it's used only when good heat resistance is needed. Electrical sockets, and other electrical components are made of PPS. So are certain part of cars, microwave ovens, and hairdryers. Its melting point 300°C. Glass transition temperature 90°C.

PPS is a crystalline material, usually supplied reinforced with glass fibres or glass fibres and mineral fillers. The chemical and ionising radiation resistance of PPS is excellent and the maximum recommended service temperature for PPS is about 200°C, although it will withstand 350°C for short periods of time. While PPS will burn and char in the presence of a flame, it is self extinguishing and any smoke that does form is lower in toxicity compared to that given off by many polymers. There are some similarities between PPS and polysulphones, with PPS usually the cheaper option. Uses of PPS include chemically resistant coatings, chemical pumps and electrical components

### UREA-FORMALDEHYDE RESIN

It is a thermosetting resin prepared by heating urea and formaldehyde in the presence of mild alkalies, such as pyridine or ammonia. The urea and formaldehyde undergo a condensation reaction in which they combine to form a water-soluble polymer. This polymer is used to formulate adhesives and coating agents or is mixed.

### Physical properties

Relative Vapour Density (air = 1): (at 20°C)1.07( For formaldehyde), Specific Gravity (20°C): 1.2– 1.4, % Volatile by Volume: 25–50 (water), Solubility in Water (g/L @ 25°C) 50, Water dilutability (mls): 100 minimum, pH (25°C): 7.8–8.2, Viscosity @ 25°C (cps): 150–250, Solids content (%): 64–66. Values may be slightly different depending upon the specific grade of resin. Urea formaldehyde resin is a colourless to milky viscous liquid, with faint formaldehyde odour. It is soluble in water and alcohol. The free formaldehyde content of UF resins is less than 5 per cent and usually less than 0.5 per cent depending on grade.

### End uses

It is most commonly used for commercially produced interior and exterior particle boards. UF polymers have proven to be very good adhesives for wooden materials. Due to their high reactivity and cost efficiency, they are the most popular binders for interior products. Adhesives based on formaldehyde are used as binders in the production of reconstituted wood panels such as particleboard, plywood, medium density fibreboard, laminated veneer lumber, finger joints and laminated beams. UF resins and other related formaldehyde resins are also used in resin impregnated decorative paper laminates, glass fibre insulation binders, foundry cores, pulp and papers processing aids, paper sizing, textile treatments, paints and enamels, and miscellaneous joinery applications.

### PF RESIN (Phenol-formaldehyde resin, phenolic resin, Bakelite)

It is a thermoset resin prepared by condensation polymerization of phenol and formaldehyde. If acid catalyst is used the resin is called Novolac and if base catalyst is employed the resulting resin is termed as resol. PF is mainly used in mouldings and laminates. Phenolics have poor tracking resistance under conditions of high humidity. This means phenolics have a tendency to form a conductive path through carbonization along a surface between two electrodes at differing potential. The most well known application of PF resin is in domestic plugs and switches. But now a days they are replaced by UF resins ( amino resins) because of their better anti-tracking properties. In car industry PF mouldings are used in fuse-box covers, distribution heads. Heat resistance PF resins are used in sauce pan handles and knobs, lamp housings, cooker handles, welding tongs. Bottle caps and closures are made from PF mouldings. PF mouldings continue to be used in many industrial applications where heat resistance, low cost and shock resistance are important features. PF resins is also used as matrix in composite industry with fibre reinforcements. Phenolic-paper laminates are used for high-voltage insulation applications. PF-cotton laminates are used in the manufacture of gear wheels. Phenolic resins are useful surface coating material. Resols are useful for storing lacquers, for coating chemical plant, textile equipment, razor blades, brassewares and food cans. PF resin is also used in formulating different adhesives for plywoods

### Ceramics materials

Ceramic materials are inorganic, nonmetallic materials. Most ceramics are compounds between metallic and nonmetallic elements for which the interatomic bonds are either totally ionic or predominantly ionic but having some covalent character. The term ceramic comes from the Greek word keramikos, which means burnt stuff, indicating that desirable properties of these materials are normally achieved through a high-temperature heat treatment process called firing. Ceramic materials are important in today's society. Consider the ceramic engine and what advantages it offers in terms of fuel economy, efficiency, weight savings and performance. Below are three gif's showing a montage of a prototype ceramic engine and some of the internal automotive components made from ceramics.

### Aluminum Oxide, Al<sub>2</sub>O<sub>3</sub>

Alumina is the most cost effective and widely used material in the family of engineering ceramics. The raw materials from which this high performance technical grade ceramic is made are readily available and reasonably priced, resulting in good value for the cost in fabricated alumina shapes. With an excellent combination of properties and an attractive

price, it is no surprise that fine grain technical grade alumina has a very wide range of applications.

#### Key Properties

Hard, wear-resistant

Excellent dielectric properties from DC to GHz frequencies Resists strong acid and alkali attack at elevated temperatures Good thermal conductivity

Excellent size and shape capability High strength and stiffness

Available in purity ranges from 94%, an easily metallizable composition, to 99.5% for the most demanding high temperature applications.

#### Typical Uses

Gas laser tubes Wear pads Seal rings

High temperature electrical insulators High voltage insulators

Furnace liner tubes Thread and wire guides Electronic substrates Ballistic armor

Abrasion resistant tube and elbow liners Thermometry sensors

Laboratory instrument tubes and sample holders Instrumentation parts for thermal property test machines Grinding media

#### General Information

Aluminum oxide, commonly referred to as alumina, possesses strong ionic interatomic bonding giving rise to its desirable material characteristics. It can exist in several crystalline phases which all revert to the most stable hexagonal alpha phase at elevated temperatures. This is the phase of particular interest for structural applications and the material available from Accuratus.

Alpha phase alumina is the strongest and stiffest of the oxide ceramics. Its high hardness, excellent dielectric properties, refractoriness and good thermal properties make it the material of choice for a wide range of applications.

High purity alumina is usable in both oxidizing and reducing atmospheres to 1925°C. Weight loss in vacuum ranges from  $10^{-7}$  to  $10^{-6}$  g/cm<sup>2</sup>.sec over a temperature range of 1700° to 2000°C. It resists attack by all gases except wet fluorine and is resistant to all common reagents except hydrofluoric acid and phosphoric acid. Elevated temperature attack occurs in the presence of alkali metal vapors particularly at lower purity levels.

The composition of the ceramic body can be changed to enhance particular desirable material characteristics. An example would be additions of chrome oxide or manganese oxide to improve hardness and change color. Other additions can be made to improve the ease and consistency of metal films fired to the ceramic for subsequent brazed and soldered assembly.

Silicon Carbide

#### Background

Sintered alpha silicon carbide is produced by initially mixing fine (sub-micron) and pure silicon carbide powder with non-oxide sintering aids. The powdered material is formed or compacted by using most of the conventional ceramic forming processes such as die

pressing, isostatic pressing and injection moulding. Following the forming stage the material is sintered in an inert atmosphere at temperatures above 2000°C. The sintered silicon carbide can then be machined to precise tolerances using a range of precision diamond grinding or lapping techniques. As with most advanced ceramics the cost of the component is reduced if the amount of diamond grinding is reduced i.e. either the material manufacturer can achieve the required tolerances “as sintered” or the designer removes unnecessary tolerances.

### Key Properties

The major properties of sintered silicon carbide of interest to the engineer or designer, are as follows:

- High hardness (second only to diamond)
- Low density 40% the density of steel – approximately the same as aluminium
- Low porosity
- Good wear resistance in sliding and abrasive environments
- Excellent corrosion resistance in most chemical environments
- Low thermal expansion and high thermal conductivity leading to excellent thermal shock resistance.

### Applications

#### Automotive Components and Seal Faces

Due to their greater resistance to both wear and thermal shock, sintered silicon carbide seal faces for automotive water pumps are replacing seal faces made of materials such as aluminium oxide. In many cases the material has proven more suitable in meeting the performance demands of U.S. and European vehicles – i.e. lasting the lifetime of the vehicle without leaking. These components are manufactured by conventional high volume pressing and injection moulding methods to meet the economic constraints of the application.

#### Armour

Sintered Silicon Carbide has demonstrated an excellent performance record as ceramic material in composite armour protection systems. The properties of sintered silicon carbide, such as its high hardness, compressive strength and elastic modulus, provide superior ballistic capability when confronted with high-velocity projectiles. The low specific density of the material makes it suitable in applications where weight requirements are critical.

#### Heat Exchanger Tubes

Sintered Silicon Carbide tubes are used in shell and tube heat exchangers in the chemical process industry. The tubes used in these applications are often over 4 m in length.

#### Mechanical Seals

Pumps must operate in an infinite variety of demanding environments. Sintered Silicon Carbide offers a high performance seal face material that has proven successful in such diverse pumping applications as chemical processing, refining, mining and pulp and paper processing. The material provides superior corrosion and abrasion resistance; shock resistance; and low sliding friction against a wide range of mating materials.

### Bearings

For state-of-the-art magnetically driven pumps, sintered silicon carbide is particularly suited for thrust and journal bearing components. Excellent corrosion resistance provides optimum performance in many chemical environments. High thermal conductivity minimizes the likelihood of failure due to thermal shock, and its specific strength makes it safe to use at high rotational speeds. Bearing components are usually produced as tight tolerance precision ground parts.

### Blast and Atomisation Nozzles

Sintered Silicon Carbide is probably the most popular ceramic alternative to tungsten carbide for blast nozzle applications. Typically providing long life (50% over WC) due to excellent wear and corrosion resistance. The low wear rate maintains the internal nozzle geometry and provides maximum blasting effectiveness, minimum compressor requirements and reduced downtime due to replacement. Sintered silicon carbide is also about one fifth the weight of Tungsten Carbide, so the blasting operation is also easier for the operator. Nozzles are often produced as semi finished (non- ground) components thereby reducing costs.

### Process Industry Valve Applications

The outstanding corrosion resistance of sintered silicon carbide, particularly in acids, makes it an ideal candidate for valve and valve trim applications. Typical demanding applications such as slurry flashing, HF acid handling and rare earth processing use sintered silicon carbide valve components.

### Paper Industry Applications

The excellent corrosion and wear resistance of sintered silicon carbide provides hard surfaces that can be machined to smooth, highly polished finishes. These finishes offer low coefficients of friction and compatibility with forming fabrics. Tiles, inserts and palm guides are available in finished and semi-finished forms.

### Centrifuge Tiles and Wear Parts

Often used in applications where tungsten carbide and alumina fail to provide optimum lifetime performance.

### Semiconductor Production

The benefit of using silicon carbide for semiconductor components includes; the thermal expansion match to silicon, the resistance to wear and chemical corrosion which leads to reduced maintenance and component recycling. The material is well suited as a structural material for low mass silicon wafer handling components and rigid, dimensionally stable platforms due to its lightness in weight and high elastic modulus. Typical applications include vacuum chucks, chemical mechanical polishing blocks, wafer carriers, and thermocouple protection tubes.

### Fused Silica, SiO<sub>2</sub>

Fused silica is a noncrystalline (glass) form of silicon dioxide (quartz, sand). Typical of glasses, it lacks long range order in its atomic structure. It's highly cross linked three dimensional structure gives rise to it's high use temperature and low thermal expansion coefficient.

### Key Properties

- ✓ Near zero thermal expansion
- ✓ Exceptionally good thermal shock resistance
- ✓ Very good chemical inertness
- ✓ Can be lapped and polished to fine finishes
- ✓ Low dielectric constant
- ✓ Low dielectric loss
- ✓ Good UV transparency

### Typical Uses

- ✓ High temperature lamp envelopes
- ✓ Temperature insensitive optical component supports
- ✓ Lenses, mirrors in highly variable temperature regimes
- ✓ Microwave and millimeter wave components
- ✓ Aeronautical radar windows

### General Information

High purity sand deposits provide the raw material for bulk refractory grade, which is electric arc melted at extremely high temperatures. Optical and general purpose fused silica rods and tubing are drawn from a melt made from high purity chemicals. Fiber optic purity is made by thermal decomposition of high purity gaseous silica containing chemicals. The glass may be clear or translucent, in which case it is often referred to as fused quartz. The glass has very high viscosity, and this property allows the glass to be formed, cooled and annealed without crystallizing. Fused silica glass is a very low thermal expansion material, and so is extremely thermal shock resistant. The material is also chemically inert up to moderate temperatures except to hydrofluoric acid, which dissolves silica. It will devitrify above about 1100°C in the presence of contaminants such as sodium, phosphorus and vanadium, with the formation of cristobalite crystals which destroy the properties of the glass. The dielectric properties are stable up through gigahertz frequencies.

### Silicon Nitride, Si<sub>3</sub>N<sub>4</sub>

Silicon nitride is a man made compound synthesized through several different chemical reaction methods. Parts are pressed and sintered by well developed methods to produce a ceramic with a unique set of outstanding properties. The material is dark gray to black in color and can be polished to a very smooth reflective surface, giving parts with a striking appearance. High performance silicon nitride materials were developed for automotive engine wear parts, such as valves and cam followers and proven effective. The cost of the ceramic parts never dropped enough to make the ceramics feasible in engines and turbochargers. The very high quality bodies developed for these demanding high reliability applications are available today and can be used in many severe mechanical, thermal and wear applications.

### Key Properties

- ✓ High strength over a wide temperature range

- ✓ High fracture toughness
- ✓ High hardness
- ✓ Outstanding wear resistance, both impingement and frictional modes
- ✓ Good thermal shock resistance
- ✓ Good chemical resistance

#### Typical Uses

- ✓ Rotating bearing balls and rollers
- ✓ Cutting tools
- ✓ Engine moving parts — valves, turbocharger rotors
- ✓ Engine wear parts — cam followers, tappet shims
- ✓ Turbine blades, vanes, buckets
- ✓ Metal tube forming rolls and dies
- ✓ Precision shafts and axles in high wear environments
- ✓ Weld positioners

#### General Information

The material is an electrical insulator and is not wet by nonferrous alloys. Silicon nitride is a rather expensive material, but its performance to cost benefit ratio is excellent in the applications where it can outperform the normally utilized materials with long life and very reliable low maintenance operation.

[www.EnggTree.com](http://www.EnggTree.com)

#### Zirconium Oxide, ZrO<sub>2</sub>

Zirconia is an extremely refractory material. It offers chemical and corrosion inertness to temperatures well above the melting point of alumina. The material has low thermal conductivity. It is electrically conductive above 600°C and is used in oxygen sensor cells and as the susceptor (heater) in high temperature induction furnaces. With the attachment of platinum leads, nernst glowers used in spectrometers can be made as a light emitting filament which operates in air.

#### Key Properties

- ✓ Use temperatures up to 2400°C
- ✓ High density
- ✓ Low thermal conductivity (20% that of alumina)
- ✓ Chemical inertness
- ✓ Resistance to molten metals
- ✓ Ionic electrical conduction
- ✓ Wear resistance
- ✓ High fracture toughness
- ✓ High hardness

### Typical Uses

- ✓ Precision ball valve balls and seats
- ✓ High density ball and pebble mill grinding media
- ✓ Rollers and guides for metal tube forming
- ✓ Thread and wire guides
- ✓ Hot metal extrusion dies
- ✓ Deep well down-hole valves and seats
- ✓ Powder compacting dies
- ✓ Marine pump seals and shaft guides
- ✓ Oxygen sensors
- ✓ High temperature induction furnace susceptors
- ✓ Fuel cell membranes
- ✓ Electric furnace heaters over 2000°C in oxidizing atmospheres

### General Information

Pure zirconia exists in three crystal phases at different temperatures. At very high temperatures ( $>2370^{\circ}\text{C}$ ) the material has a cubic structure. At intermediate temperatures ( $1170$  to  $2370^{\circ}\text{C}$ ) it has a tetragonal structure. At low temperatures (below  $1170^{\circ}\text{C}$ ) the material transforms to the monoclinic structure. The transformation from tetragonal to monoclinic is rapid and is accompanied by a 3 to 5 percent volume increase that causes extensive cracking in the material. This behavior destroys the mechanical properties of fabricated components during cooling and makes pure zirconia useless for any structural or mechanical application. Several oxides which dissolve in the zirconia crystal structure can slow down or eliminate these crystal structure changes. Commonly used effective additives are  $\text{MgO}$ ,  $\text{CaO}$ , and  $\text{Y}_2\text{O}_3$ . With sufficient amounts added, the high temperature cubic structure can be maintained to room temperature. Cubic stabilized zirconia is a useful refractory and technical ceramic material because it does not go through destructive phase transitions during heating and cooling.

The volume expansion of the tetragonal to monoclinic inversion is used to produce very high strength, hard, tough varieties of zirconia for mechanical and structural applications. There are several different mechanisms that lead to strengthening and toughness in zirconias that contain tetragonal grains. This is a complex subject matter. Simplistically, these depend on the grain sizes, the thermal history and the kind and amount of stabilizing additive in the body. These variations lead to two strong materials identified as TZP and PSZ ceramics. The PSZ is the more common commercial material and is made as a  $\text{MgO}$  partially stabilized zirconia. The second variety, TZP, is a pure tetragonal very fine grain material. This material, which is challenging to produce, has found uses in cutting and wear resistant applications due to its reliable and outstanding hardness and toughness. TZP properties degrade rapidly when the material is exposed to water vapor at  $200$  to  $300^{\circ}\text{C}$ , so controlled use conditions are important for good performance. All of the toughened zirconias show a degrading of properties with increasing temperature, and this class of high strength, tough materials is generally limited to use temperatures below  $800^{\circ}\text{C}$ .

Calcium oxide stabilized zirconia is popular for coarser grain refractory bodies for crucibles, kiln furniture and kiln refractories operated in the  $2000^{\circ}\text{C}$  range. Magnesium



oxide is the most popular stabilizer added to produce a very strong and tough fine grain ceramics for mechanical and structural applications. Yttria, due to its high cost, is used in specialty applications which take advantage of the superior electronic and ionic electrical conduction of the material.

*Typical applications:* electrical insulators; seal faces; valve seats.

## SIALON

Sialon, a fine grain nonporous technical grade engineering material, is a silicon nitride ceramic with a small percentage of aluminum oxide added. Sialon is outstanding in nonferrous metal contact. It is highly thermal shock resistant, strong, and is not wet or corroded by aluminum, brass, bronze, and other common industrial metals.

### Key Properties

- ✓ Excellent thermal shock resistance
- ✓ Not wetted or corroded by nonferrous metals
- ✓ High strength
- ✓ Good fracture toughness
- ✓ Good high temperature strength
- ✓ Low thermal expansion
- ✓ Good oxidation resistance

### Typical Uses

- ✓ Thermocouple protection tubes for nonferrous metal melting
- ✓ Immersion heater and burner tubes
- ✓ Degassing and injector tubes in nonferrous metals
- ✓ Metal feed tubes in aluminum die casting
- ✓ Welding and brazing fixtures and pins

### General Information

The combination of silicon nitride and aluminum oxide produces a material with the excellent strength, hardness, fracture toughness and low thermal expansion of silicon nitride, enhanced by corrosion resistance, good high temperature strength and oxidation

The SiAlONs were developed as a more economic alternative to hot pressed silicon nitride. SiAlONs have a complex chemistry and should be thought of as a family of alloys with a wide range of properties. They are formed when silicon nitride ( $\text{Si}_3\text{N}_4$ ), aluminium oxide ( $\text{Al}_2\text{O}_3$ ) and aluminium nitride (AlN) are reacted together. The materials combine over a wide compositional range. Fully dense polycrystalline bodies can be formed by pressureless sintering if sintering aids such as yttrium oxide are added to the compact. This innovation allows near net complex shaped components made at an economic cost. The most commonly used compositions at present are  $\beta$ - SiAlON and  $(\alpha + \beta)$  SiAlONs, which contain a substantial excess of sintering aids. However, the field is still changing with compositions developing to suit specific applications.

Key Properties SiAlONs exploit the following properties:

- low density,
- high strength
- superior thermal shock resistance,
- moderate wear resistance
- fracture toughness,
- mechanical fatigue and creep resistance,
- oxidation resistance.

In pressureless sintered materials, the high temperature properties are limited by the glassy phases that form at grain boundaries during sintering. These materials are only suitable to long term use at temperatures of less than 1000°C. Typical properties are outlined in table 1.

Table 1. Typical Physical and Mechanical Properties of SiAlON

Property	
Density (g.cm-3)	3.30
Young's Modulus (GPa)	290
Bend Strength (MPa)	800
Fracture Toughness K1c (MPa.m 0.5)	6.2
Hardness, (GPa)	17
Thermal Expansion Coefficient (x 10-6/°C)	3.3
Thermal Conductivity (W/m.K)	18
Maximum Operating Temperature (°C)	1000

Properties may vary widely as the family of materials known as SiAlONs covers a vast compositional range.

#### Applications Cutting Tools

The hot hardness, fracture toughness and thermal shock resistance of fully dense SiAlON makes it well suited to use in cutting tools. The material is an attractive low cost alternative to hot pressed silicon nitride for machining grey cast iron for automotive applications. The material gives increased metal removal rate and longer tool life compared with conventional cutting tools.

SiAlONs have also replaced cemented carbide tools when machining nickel based superalloys. These alloys are used for their heat resistance or in aerospace applications and are notoriously difficult to machine. Pressureless sintered SiAlON can also increase tool life by up to 10 times in comparison with silicon nitride tools when machining these alloys.

#### Wear Components

Wear components exploit the electrical insulation, low thermal conductivity, and wear and thermal shock resistance of the material. Representative wear applications are fixtures for positioning and transferring metal parts during processes such as induction heating or resistance welding. For example, SiAlON has been used to make location pins when resistance welding automotive components. The conventional hardened steel pin with an alumina sleeve lasted 8 hours, whilst the SiAlON pin lasted one year.

### Metal Forming Tools

SiAlONs have been used in metal wire and tube drawing tools for non-ferrous metals such as copper and aluminium alloys. In general the hardness, low coefficient of friction and lack of adhesion and reaction have given good results. High levels of copper oxide in copper alloys must be avoided however, as it attacks the material and tolerance control is lost.

### Composite Materials

Man's evolution has been tied to his progress in materials. Yesterday it was the Stone, Bronze and Iron Ages. Today it is the Age of Composites. However, even in these earlier ages man experimented with and learned to use composite materials. This is evidenced by the Israelites' use of chopped straw in their brick; the Egyptian sarcophagi fashioned from glued and laminated wood veneer and also their use of cloth tape soaked in resin for mummy embalming; the Mongol warriors' high-performance, recurved archery bows of bullock tendon, horn, bamboo strips, silk and pine resin, which are 80% as strong as our modern fiberglass bows; Chinese bamboo rockets reinforced with rope wrappings; Japanese Samurai swords formed by the repeated folding of a steel bar back on itself; the early fabrication of steel and of iron gun barrels in Damascus; and the Roman artisans' use of ground marble in their lime plaster, frescoes and pozzolanic mortar. The ancients also used goat hair in their clay for the fabrication of pottery which, after firing, was converted to a form of carbon, the forerunner of modern carbon fiber reinforced ceramics.

A composite material is a multiphase material, which is composed of at least two basic elements working together to produce material properties that are different to the properties of those elements on their own. In practice, most composites consist of a bulk material (the 'matrix'), and a reinforcement of some kind, added primarily to increase the strength and stiffness of the matrix. This reinforcement is usually in fibre form. Composites maintain an interface between components and act in concert to provide improved specific or synergistic characteristics not obtainable by any of the original components acting alone. The definition will allow the inclusion of natural materials such as wood which consists of cellulose fibers bonded together with lignin and other carbohydrate constituents, as well as the silk fiber spun by a spider which is as strong as steel on a weight basis consisting of a gel core encased in a solid protein structure as composite materials. Composites include: (1) fibrous (composed of fibers, and usually in a matrix), (2) laminar (layers of materials), (3) particulate (composed of particles or flakes, usually in a matrix), and (4) hybrid (combinations of any of the above).

Today, the most common man-made composites can be divided into three main groups:

1. Polymer Matrix Composites (PMC's) – These are the most common and will be discussed here. Also known as FRP - Fibre Reinforced Polymers (or Plastics) – these

materials use a polymer-based resin as the matrix, and a variety of fibres such as glass, carbon and aramid as the reinforcement.

2. Metal Matrix Composites (MMC's) - Increasingly found in the automotive industry, these materials use a metal such as aluminium as the matrix, and reinforce it with fibres such as silicon carbide.

3. Ceramic Matrix Composites (CMC's) - Used in very high temperature environments, these materials use a ceramic as the matrix and reinforce it with short fibres, or whiskers such as those made from silicon carbide and boron nitride.

Resin systems such as epoxies and polyesters have limited use for the manufacture of structures on their own, since their mechanical properties are not very high when compared to, for example, most metals. However, they have desirable properties, most notably their ability to be easily formed into complex shapes. Materials such as glass, aramid and boron have extremely high tensile and compressive strength but in 'solid form' these properties are not readily apparent. This is due to the fact that when stressed, random surface flaws will cause each material to crack and fail well below its theoretical 'breaking point'. To overcome this problem, the material is produced in fibre form, so that, although the same number of random flaws will occur, they will be restricted to a small number of fibres with the remainder exhibiting the material's theoretical strength. Therefore a bundle of fibres will reflect more accurately the optimum performance of the material. However, fibres alone can only exhibit tensile properties along the fibre's length, in the same way as fibres in a rope.

It is when the resin systems are combined with reinforcing fibres such as glass, carbon and aramid that exceptional properties can be obtained. The resin matrix spreads the load applied to the composite between each of the individual fibres and also protects the fibres from damage caused by abrasion and impact. High strengths and stiffnesses, ease of moulding complex shapes, high environmental resistance all coupled with low densities, make the resultant composite superior to metals for many applications. Since PMC's combine a resin system and reinforcing fibres, the properties of the resulting composite material will combine something of the properties of the resin on its own with that of the fibres on their own, as surmised in

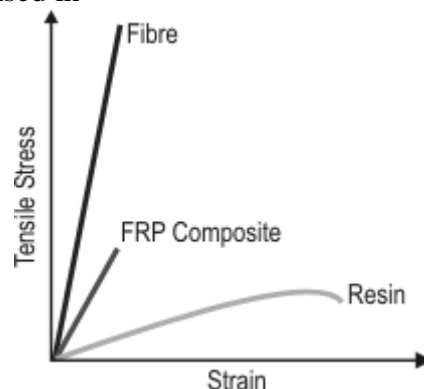

Figure 4.1 Illustrating the combined effect on Modulus of the addition of fibres to a resin matrix Overall, the properties of the composite are determined by the ,

- 1) properties of the fibre,
- 2) properties of the resin,
- 3) ratio of fibre to resin in the composite (Fibre Volume Fraction (FVF) and

#### 4) geometry and orientation of the fibres in the composite

The ratio of the fibre to resin derives largely from the manufacturing process used to combine resin with fibre. However, it is also influenced by the type of resin system used, and the form in which the fibres are incorporated. In general, since the mechanical properties of fibres are much higher than those of resins, the higher the fibre volume fraction (FVF) the higher will be the mechanical properties of the resultant composite. In practice there are limits to this, since the fibres need to be fully coated in resin to be effective, and there will be an optimum packing of the generally circular cross-section fibres. In addition, the manufacturing process used to combine fibre with resin leads to varying amounts of imperfections and air inclusions. Typically, with a common hand lay-up process as widely used in the boat-building industry, a limit for FVF is approximately 30-40%. With the higher quality, more sophisticated and precise processes used in the aerospace industry, FVF's approaching 70% can be successfully obtained.

The geometry of the fibres in a composite is also important since fibres have their highest mechanical properties along their lengths, rather than across their widths. This leads to the highly anisotropic properties of composites, where, unlike metals, the mechanical properties of the composite are likely to be very different when tested in different directions. This means that it is very important when considering the use of composites to understand at the design stage, both the magnitude and the direction of the applied loads. When correctly accounted for, these anisotropic properties can be very advantageous since it is only necessary to put material where loads will be applied, and thus redundant material is avoided.

It is also important to note that with metals the material supplier largely determines the properties of the materials, and the person who fabricates the materials into a finished structure can do almost nothing to change those 'in-built' properties. However, a composite material is formed at the same time, as the structure is itself being fabricated. This means that the person who is making the structure is creating the properties of the resultant composite material, and so the manufacturing processes they use have an unusually critical part to play in determining the performance of the resultant structure.

#### Loads on composites

There are four main direct loads that any material in a structure has to withstand: tension, compression, shear and flexure.

#### Tension

Figure 4.2 shows a tensile load applied to a composite. The response of a composite to tensile loads is very dependent on the tensile stiffness and strength properties of the reinforcement fibres, since these are far higher than the resin system on its own.

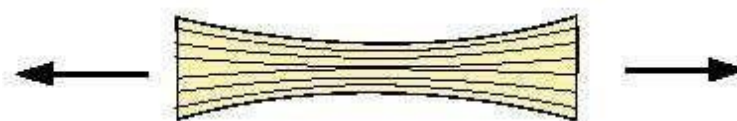

Figure 4.2 Tensile load applied to a composite body

Compression

Figure 4.3 shows a composite under a compressive load. Here, the adhesive and stiffness properties of the resin system are crucial, as it is the role of the resin to maintain the fibres as straight columns and to prevent them from buckling

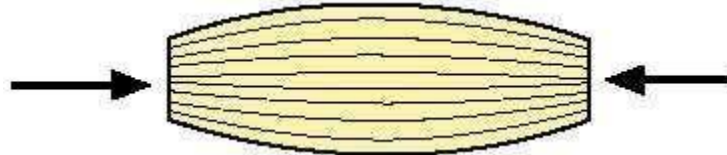

Figure 4.3 - Illustrates the compression load applied to a composite body.

Shear

Figure 4.4 shows a composite experiencing a shear load. This load is trying to slide adjacent layers of fibres over each other. Under shear loads the resin plays the major role, transferring the stresses across the composite. For the composite to perform well under shear loads the resin element must not only exhibit good mechanical properties but must also have high adhesion to the reinforcement fibre. The interlaminar shear strength (ILSS) of a composite is often used to indicate this property in a multiplyer composite ('laminate').



Figure 4.4 - Illustrates the shear load applied to a composite body.

Flexure

Flexural loads are really a combination of tensile, compression and shear loads. When loaded as shown (Figure 4.5), the upper face is put into compression, the lower face into tension and the central portion of the laminate experiences shear

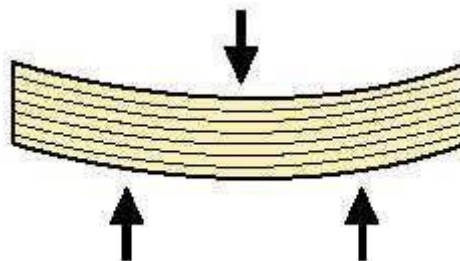

Figure 4.5 - Illustrates the loading due to flexure on a composite body.

Due to the factors described above, there is a very large range of mechanical properties

that can be achieved with composite materials. Even when considering one fibre type on its own, the composite properties can vary by a factor of 10 with the range of fibre contents and orientations that are commonly achieved. The comparisons that follow therefore show a range of mechanical properties for the composite materials. The lowest properties for each material are associated with simple manufacturing processes and material forms (e.g. spray lay-up glass fibre), and the higher properties are associated with higher technology manufacture (e.g. autoclave moulding of unidirectional glass fibre prepreg), such as would be found in the aerospace industry. A range of strength and stiffness (modulus) figures for different materials are given in Figure 4.6 to compare the spread of properties associated with composites and other structural materials

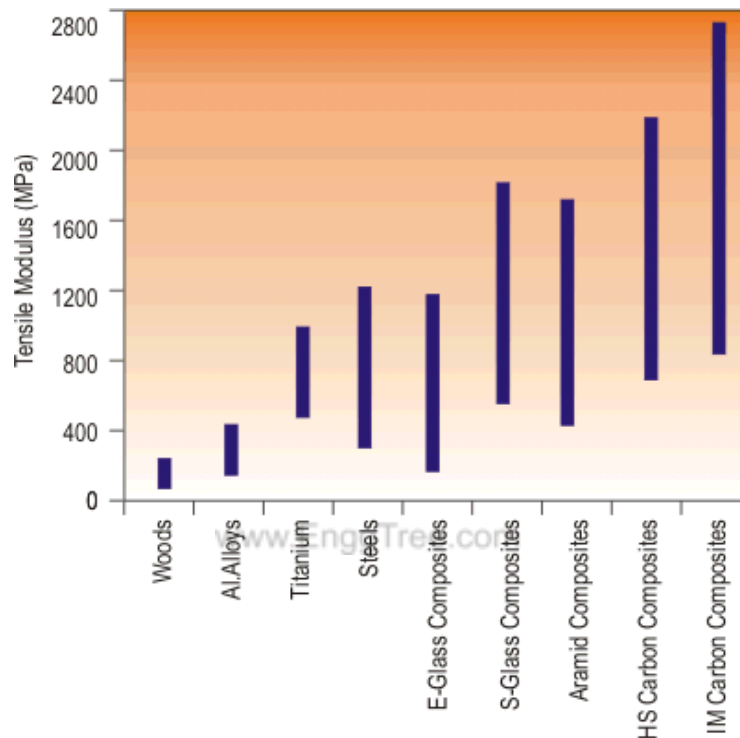

Figure 4.6 – Tensile Strength of Common Structural Materials  
Particulate Composites

Particle-reinforced composites are candidate materials for a wide variety of aerospace and nonaerospace applications. The high costs and technical difficulties involved with the use of many fiber-reinforced composites often limit their use in many applications. Consequently, particulate composites have emerged as viable alternatives to conventional fiber-reinforced composites. Particulate composites can be processed to near net shape potentially reducing the manufacturing costs. They are candidate materials where shock or impact properties are important. For example, particle-reinforced metal matrix composites have shown great potential for many automotive applications. Typically, these materials are aluminum matrix reinforced with SiC or TiC particles. Reinforced concrete can also be thought of as a particle-reinforced composite. In situ ceramics can be modeled as particulate composites and are candidate materials for many high-temperature applications. The characterization of these materials is fundamental to their reliable use. It has been observed that the overall properties of these composites exhibit scatter because of the uncertainty in the constituent material properties, and fabrication-related parameters.

The observed scatter in the global composite behavior or "response" is usually caused by the existence of uncertainties in the basic or "primitive" variables. Primitive variables are properties or parameters that participate at the lowest or micromechanics level in defining a global or homogenized property. Volume fractions and individual constituent properties such as moduli, thermal expansion coefficients, thermal conductivities, and strengths are examples of primitive variables. They are assumed to be independent and have their own statistical distributions. Response variables are those that characterize such composite behavior as the composite moduli, thermal properties, and strengths.

Ceradyne manufactures a family of particulate composites, called "lossy" ceramics, whose purpose is to selectively absorb microwave energy of unwanted frequencies enabling the tube to produce energy at the desired frequency. These composites have tailored dielectric and loss properties to allow them to be matched to specific microwave tube applications. The Ceralloy® 6700 family of MgO-SiC compositions are designed to absorb microwave energy in very specific frequency ranges. The Ceralloy® 7700 family of Al<sub>2</sub>O<sub>3</sub>-SiC compositions and the Ceralloy® 13700 AlN-SiC compositions and the Ceralloy® 137 AlN based composites are broadband absorbers. The AlN composites have high thermal conductivities designed to aid in heat dissipation within the microwave tube. MgO-SiC , Al<sub>2</sub>O<sub>3</sub>-SiC , AlN-SiC etc are examples particulate composites .



## UNIT –V

Mechanisms of plastic deformation, slip and twinning

Types of fracture

Testing of materials under tension, compression and shear loads –

Hardness tests (Brinell, Vickers and Rockwell), hardness tests,

Impact test Izod and Charpy,

Fatigue and creep failure mechanisms.

## MECHANICAL PROPERTIES AND TESTING

### Plastic Deformation

When a material is stressed below its elastic limit, the resulting deformation or strain is temporary. Removal of stress results in a gradual return of the object to its original dimensions. When a material is stressed beyond its elastic limit, plastic or permanent deformation takes place, and it will not return to its original shape by the application of force alone. The ability of a metal to undergo plastic deformation is probably its most outstanding characteristic in comparison with other materials. All shaping operations such as stamping, pressing, spinning, rolling, forging, drawing, and extruding involve plastic deformation of metals. Various machining operations such as milling, turning, sawing, and punching also involve plastic deformation. Plastic deformation may take place by:

[www.EnggTree.com](http://www.EnggTree.com)

### Slip Twinning

Combination of slip and twinning Deformation by Slip:

If a single crystal of a metal is stressed in tension beyond its elastic limit, it elongates slightly, a step appears on the surface indicating relative displacement of one part of the crystal with respect to the rest, and the elongation stops. Increasing the load will cause another step. It is as if neighboring thin sections of the crystal had slipped past one another like sliding cards on a deck. Each successive elongation requires a higher stress and results in the appearance of another step, which is actually the intersection of a slip plane with the surface of the crystal. Progressive increase of the load eventually causes the material to fracture.

Slip occurs in directions in which the atoms are most closely packed, since this requires the least amount of energy.

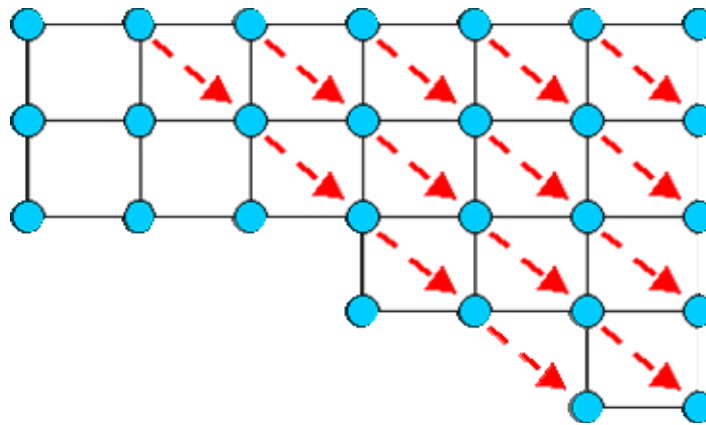

Figure 5.1 The effect of slip on the lattice structure.

Figure 1 shows that when the plastic deformation is due to slip, the atoms move a whole interatomic space (moving from one corner to another corner of the unit cell). This means that overall lattice structure remains the same. Slip is observed as thin lines under the microscopes and these lines can be removed by polishing.

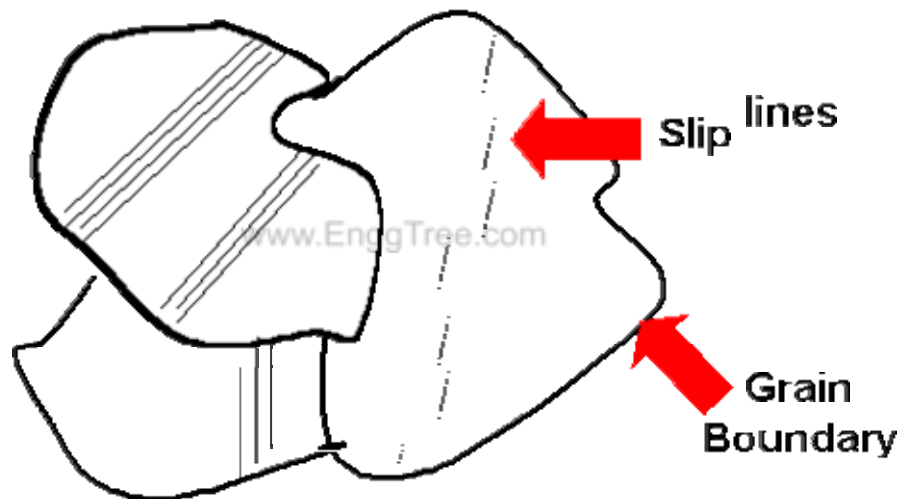

Figure 5.2 Slip appears as thin lines under the microscope.



Figure 5.3 Slip lines in copper.

#### Deformation by Twinning:

When mechanical deformation is created by twinning, the lattice structure changes. The atoms move only a fraction of an interatomic space and this leads to a rearrangement of the lattice structure.

[www.EnggTree.com](http://www.EnggTree.com)

Twinning is observed as wide bands under the microscope. These wide bands can not be removed by polishing.

Two kinds of twins are of interest to the metallurgists:

1. Deformation or mechanical twins, most prevalent in close packed hexagonal metals (magnesium, zinc, iron with large amount of ferrite)
2. Annealing twins, most prevalent in F.C.C. (Face centered cubic) metals (aluminum, copper, brass, iron with austenite). These metals have been previously worked and heat treated. The twins are formed because of a change in the normal growth mechanism.

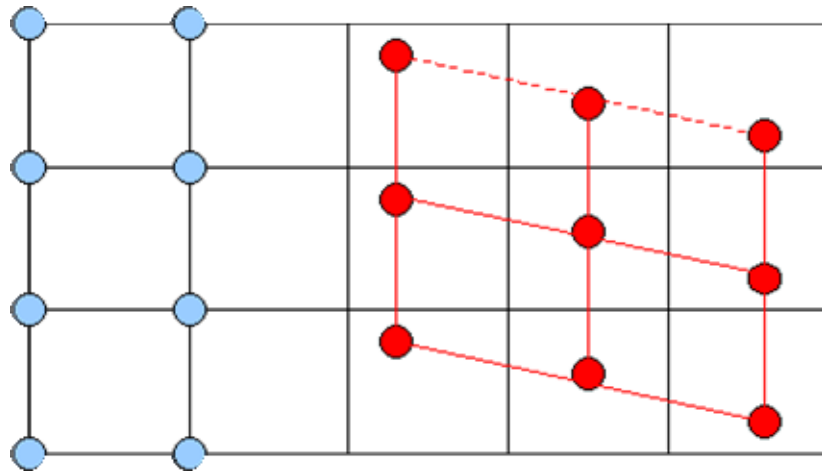

Figure 5.4 The effect of twinning on the lattice structure.

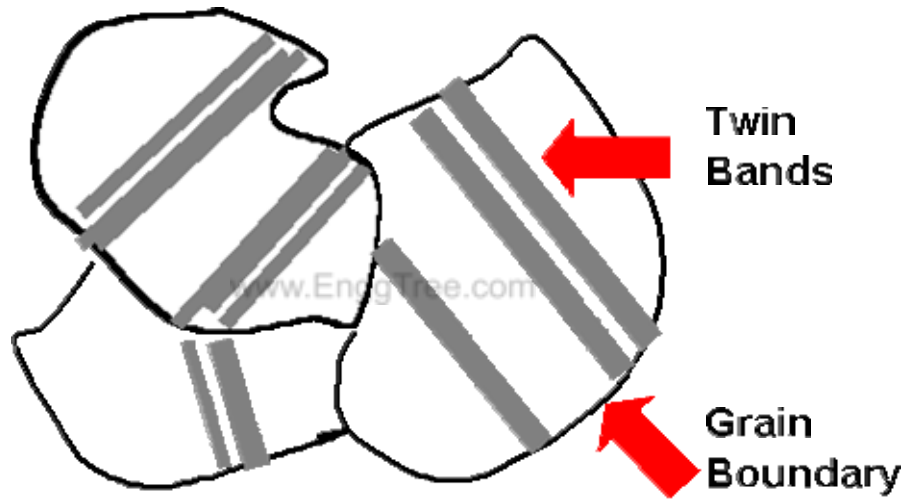

Figure 5.5 Twin bands



Figure 5.6. Twin bands in zinc.

Slip vs. Twinning:

	Slip	Twinning
Atomic movement	Atoms move a whole number of atomic spacing.	Atoms move fractional atomic spacing.
Microscopic appearance	Thin lines	Wide bands or broad lines
Lattice orientation	No change in lattice orientation. The steps are only visible on the surface of the crystal and can be removed by polishing. After polishing there is no evidence of slip.	Lattice orientation changes. Surface polishing will not destroy the evidence of twinning.

## Fracture

Fracture is an inhomogeneous process of deformation that makes regions of material to separate and load-carrying capacity to decrease to zero. It can be viewed on many levels, depending on the size of the fractured region that is of interest. At the atomistic level fracture occurs over regions whose dimensions are of the order of the atomic spacing ( $m$ ); at the microscopic level fracture occurs over regions whose dimensions are of the order of the grain size (about  $10\mu m$ ); and at the macroscopic level fracture occurs over dimensions that are of the order of the size of flaws or notches ( $1\text{ mm}$  or greater).

At each level there are one or more criteria that describe the conditions under which fracture can occur. For example, at the atomistic level fracture occurs when bonds between atoms are broken across a fracture plane and new crack surface is created. This can occur by breaking bonds perpendicular to the fracture plane, a process called cleavage, or by shearing bonds across the fracture plane, a process called shear. At this level the fracture criteria are simple; fracture occurs when the local stresses build up either to the theoretical cohesive strength  $\sigma_c \approx E/10$  or to the theoretical shear strength  $\tau_c \approx G/10$ , where  $E$  and  $G$  are the respective elastic and shear modulus. The high stresses required to break atomic bonds are concentrated at the edges of inhomogeneities that are called micro cracks or macro cracks (flaws, notches, cracks). At the microscopic and macroscopic levels fracture results from the passage of a crack through a region of material. The type of fracture that occurs is characterized by the type of crack responsible for the fracture.

www.EnggTree.com

Few structural materials are completely elastic; localized plastic strain usually precedes fracture, even when the gross fracture strength is less than the gross yield strength. Fracture in these instances is initiated when a critical amount of local plastic strain or plastic work occurs at the tip of a flaw. From the principles of fracture mechanics it is possible to determine macroscopic fracture criteria in terms of the nominal fracture strength, the flaw length, and the critical amount of plastic work required to initiate unstable fracture -- the fracture toughness.

### Types of Fracture That Occur Under Uniaxial Tensile Loading

Cleavage fractures occur when a cleavage crack spreads through a solid under a tensile component of the externally applied stress. The material fractures because the concentrated tensile stresses at the crack tip are able to break atomic bonds. In many crystalline materials certain crystallographic planes of atoms are most easily separated by this process and these are called cleavage planes.

Under uniaxial tensile loading the crack tends to propagate perpendicularly to the tensile axis. When viewed in profile, cleavage fractures appear "flat" or "square", and these terms are used to describe them.

Most structural materials are polycrystalline. The orientation of the cleavage plane(s) in

each grain of the aggregate is usually not perpendicular to the applied stress so that, on a microscopic scale, the fractures are not completely flat over distances larger than the grain size. In very brittle materials cleavage fractures can propagate continuously from one grain to the next. However, in materials such as mild steel the macroscopic cleavage fracture is actually discontinuous on a microscopic level; most of the grains fracture by cleavage but some of them fail in shear, causing the cleaved grains to link together by tearing.

Shear fracture, which occurs by the shearing of atomic bonds, is actually a process of extremely localized (inhomogeneous) plastic deformation. In crystalline solids, plastic deformation tends to be confined to crystallographic planes of atoms which have a low resistance to shear. Shear fracture in pure single crystals occurs when the two halves of the crystal slip apart on the crystallographic glide planes that have the largest amount of shear stress resolved across them. When the shear occurs on only one set of parallel planes, a slant fracture is formed.

In polycrystalline materials the advancing shear crack tends to follow the path of maximum resolved shear stress. This path is determined by both the applied stress system and the presence of internal stress concentrators such as voids, which are formed at the interface between impurity particles (e.g., nonmetallic inclusions) and the matrix material. Crack growth takes place by the formation of voids and their subsequent coalescence by localized plastic strains.

[www.EnggTree.com](http://www.EnggTree.com)

Shear fracture in thick plates and round tensile bars of structural materials begins in the center of the structure (necked region) and spreads outwards. The macroscopic fracture path is perpendicular to the tensile axis. On a microscopic scale the fracture is quite jagged, since the crack advances by shear failure (void coalescence) on alternating planes inclined at 30-45° to the tensile axis.

This form of fracture is commonly labeled normal rupture (since the fracture path is normal to the tensile axis) or fibrous fracture (since the jagged fracture surface has a fibrous or silky appearance). Normal rupture forms the central (flat) region of the familiar cup-cone pattern. The structure finally fails by shear rupture (shear lip formation) on planes inclined at 45° to the tensile axis. This form of fracture is less jagged, appears smoother, and occurs more rapidly than the normal rupture which precedes it. Similarly noncleavage fracture in thin sheets of engineering materials occurs exclusively by shear rupture and the fracture profile appears similar to the slant fracture.

Under certain conditions the boundary between adjacent grains in the poly-crystalline aggregate is weaker than the fracture planes in the grains themselves. Fracture then occurs intergranularly, by one of the processes mentioned above, rather than through the grains (transgranular fracture). Thus there are six possible modes of fracture: transgranular cleavage, transgranular shear rupture, transgranular normal rupture, and intergranular cleavage, intergranular shear rupture, intergranular normal rupture.

Fracture takes place by that mode which requires the least amount of local strain at the tip of the advancing crack. Both the environmental fracture exclusively by one particular mode over a large variety of conditions and the state of applied (nominal) stress and strain determine the type of fracture which occurs, and only a few materials and structures operating conditions (i.e., service temperature, corrosive environment, and so on).

Furthermore, under any given condition more than one mode of fracture can cause failure of a structural member and the fracture is described as "mixed". This implies that the relative ease of one type of crack propagation can change, with respect to another type, as the overall fracture process takes place. For example, normal rupture, cleavage, and shear rupture are all observed on the fracture surfaces of notched mild steel specimens broken in impact at room temperature.

In order to analyze the fracture process under various types of stress systems, it is necessary to establish a coordinate system with respect to both the fracture plane, the direction of crack propagation, and the applied stress system.

One of the difficulties encountered by engineers and scientists who are interested in a particular aspect of the fracture problem is the large mass of notation and coordinate systems used by other workers who have investigated similar problems.

[www.EnggTree.com](http://www.EnggTree.com)

Three distinct modes of separation at the crack tip can occur:

- Mode I -- The tensile component of stress is applied in the  $y$  direction, normal to the faces of the crack, either under plane-strain (thick plate,  $t$  large) or plane-stress (thin plate,  $t$  small) conditions.
- Mode II -- The shear component of stress is applied normal to the leading edge of the crack either under plane-strain or plane-stress conditions.
- Mode III -- The shear component of stress is applied parallel to the leading edge of the crack (antiplane strain).

### Summary

1. Fracture is an inhomogeneous form of deformation which can be viewed on different levels. On an atomistic level it occurs by the breaking of atomic bonds, either perpendicular to a plane (cleavage) or across a plane (shear). On a microscopic level cleavage occurs by the formation and propagation of microcracks and the separation of grains along cleavage planes. Shear fracture (rupture) usually occurs by the formation of voids within grains and the separation of material between the voids by intense shear.

On a macroscopic level cleavage occurs when a cleavage crack spreads essentially perpendicular to the axis of maximum tensile stress. Shear fracture occurs when a fibrous



crack advances essentially perpendicular to the axis of maximum tensile stress (normal rupture) or along a plane of maximum shear stress (shear rupture).

Fracture is said to be transgranular when microcrack propagation and void coalescence occur through the grains and intergranular when they occur along grain boundaries. More than one mode of crack propagation can contribute to the fracture of a structure. In general, cleavage fracture is favored by low temperatures.

2 Fracture occurs in a perfectly elastic solid when the stress level at the tip of a preinduced flaw reaches the theoretical cohesive stress  $E/10$  and a sufficient amount of work  $\gamma_s$  is done to break atomic bonds and create free surface.

When the yield stress of a material is less than  $E/10$  (i.e., in a ductile material or in the vicinity of a stopped crack in a partially brittle one), plastic flow occurs near the crack tip and the stress level in the plastic zone is less than  $E/10$ . Consequently the crack cannot advance directly as an elastic Griffith crack.

### Tensile test

A tensile test, also known as tension test, is probably the most fundamental type of mechanical test you can perform on material. Tensile tests are simple, relatively inexpensive, and fully standardized. By pulling on something, you will very quickly determine how the material will react to forces being applied in tension. As the material is being pulled, you will find its strength along with how much it will elongate.

### Why Perform a Tensile Test or Tension Test?

You can learn a lot about a substance from tensile testing. As you continue to pull on the material until it breaks, you will obtain a good, complete tensile profile. A curve will result showing how it reacted to the forces being applied. The point of failure is of much interest and is typically called its "Ultimate Strength" or UTS on the chart.

### Hooke's Law

For most tensile testing of materials, you will notice that in the initial portion of the test, the relationship between the applied force, or load, and the elongation the specimen exhibits is linear. In this linear region, the line obeys the relationship defined as "Hooke's Law" where the ratio of stress to strain is a constant, or  $\frac{\sigma}{\epsilon} = E$ .  $E$  is the slope of the line in this region where stress ( $\sigma$ ) is proportional to strain ( $\epsilon$ ) and is called the "Modulus of Elasticity" or "Young's Modulus".

### Modulus of Elasticity

Select image to enlarge The modulus of elasticity is a measure of the stiffness of the

material, but it only applies in the linear region of the curve. If a specimen is loaded within this linear region, the material will return to its exact same condition if the load is removed. At the point that the curve is no longer linear and deviates from the straight-line relationship, Hooke's Law no longer applies and some permanent deformation occurs in the specimen. This point is called the "elastic, or proportional, limit". From this point on in the tensile test, the material reacts plastically to any further increase in load or stress. It will not return to its original, unstressed condition if the load were removed.

### Yield Strength

A value called "yield strength" of a material is defined as the stress applied to the material at which plastic deformation starts to occur while the material is loaded.

### Offset Method

For some materials (e.g., metals and plastics), the departure from the linear elastic region cannot be easily identified. Therefore, an offset method to determine the yield strength of the material tested is allowed. These methods are discussed in ASTM E8 (metals) and D638 (plastics). An offset is specified as a % of strain (for metals, usually 0.2% from E8 and sometimes for plastics a value of 2% is used). The stress (R) that is determined from the intersection point "r" when the line of the linear elastic region (with slope equal to Modulus of Elasticity) is drawn from the offset "m" becomes the Yield Strength by the offset method.

www.EnggTree.com

### Alternate Moduli

The tensile curves of some materials do not have a very well-defined linear region. In these cases, ASTM Standard E111 provides for alternative methods for determining the modulus of a material, as well as Young's Modulus. These alternate moduli are the secant modulus and tangent modulus.

### Strain

You will also be able to find the amount of stretch or elongation the specimen undergoes during tensile testing. This can be expressed as an absolute measurement in the change in length or as a relative measurement called "strain". Strain itself can be expressed in two different ways, as "engineering strain" and "true strain". Engineering strain is probably the easiest and the most common expression of strain used. It is the ratio of the

$$= \frac{\Delta L}{L_0} \quad e = \frac{L - L_0}{L_0}$$

change in length to the original length,

Whereas, the true strain is similar but based on the instantaneous length of the specimen as the

$$\epsilon = \ln\left(\frac{L_i}{L_0}\right)$$

test progresses,

where  $L_i$  is the instantaneous length and  $L_0$  the initial length.

### Ultimate Tensile Strength

One of the properties you can determine about a material is its ultimate tensile strength (UTS). This is the maximum load the specimen sustains during the test. The UTS may or may not equate to the strength at break. This all depends on what type of material you are testing. . .brittle, ductile, or a substance that even exhibits both properties. And sometimes a material may be ductile when tested in a lab, but, when placed in service and exposed to extreme cold temperatures, it may transition to brittle behavior.

### Compression Test

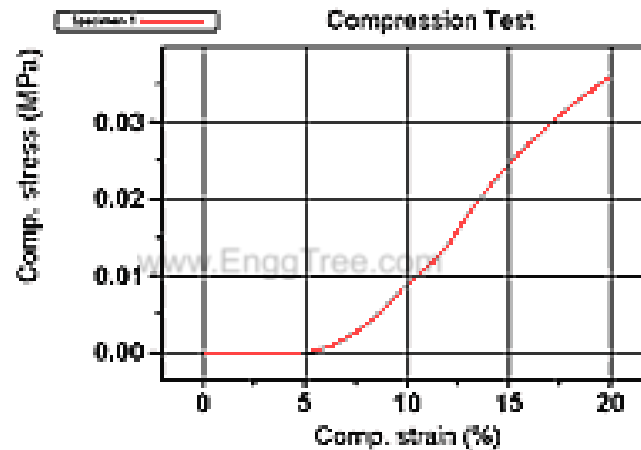

A compression test determines behavior of materials under crushing loads. The specimen is compressed and deformation at various loads is recorded. Compressive stress and strain are calculated and plotted as a stress-strain diagram which is used to determine elastic limit, proportional limit, yield point, yield strength and, for some materials, compressive strength.

Compression testing is a useful procedure for measuring the plastic flow behavior and ductile fracture limits of a material. Measuring the plastic flow behavior requires frictionless (homogenous compression) test conditions, while measuring ductile fracture limits takes advantage of the barrel formation and controlled stress and strain conditions at the equator of the barreled surface when compression is carried out with friction.

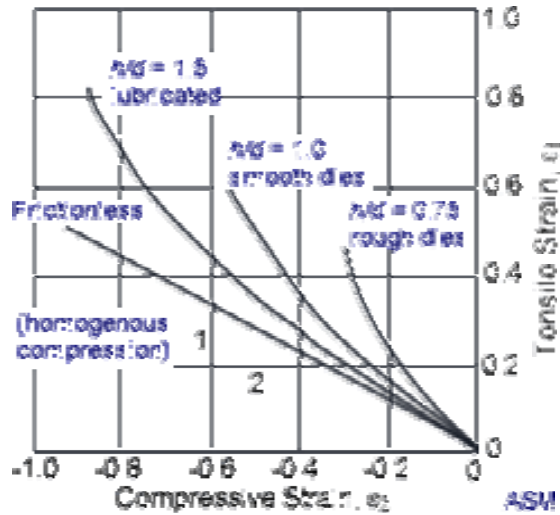

Axial compression testing is also useful for measurement of elastic and compressive fracture properties of brittle materials or low-ductility materials. In any case, the use of specimens having

1 large L/D ratios should be avoided to prevent buckling and shearing modes of deformation ."

The image at right shows variation of the strains during a compression test without friction (homogenous compression) and with progressively higher levels of friction and decreasing aspect

1 ratio L/D (shown as h/d) .

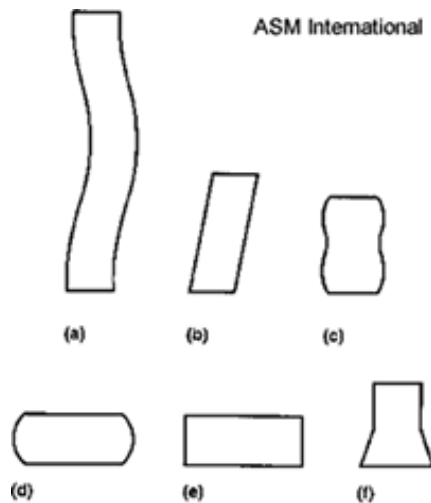

### Modes of Deformation in Compression Testing

The figure to the right illustrates the modes of deformation in compression testing. (a) Buckling, when  $L/D > 5$ . (b) Shearing, when  $L/D > 2.5$ . (c) Double barreling, when  $L/D > 2.0$  and friction is present at the contact surfaces. (d) Barreling, when  $L/D < 2.0$  and friction is present at the contact surfaces. (e) Homogenous compression, when  $L/D < 2.0$  and no friction is present at the contact

1

surfaces. (f) Compressive instability due to work-softening material .

### Typical Materials

The following materials are typically subjected to a compression test.

Concrete Metals Plastics Ceramics Composites

### 4.5 Charpy and Izod Pendulum Impact Test

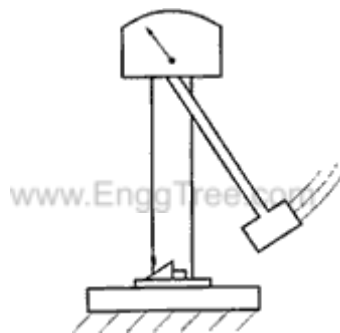

*In the beginning . . .*

During the first part of the 20th century, a metallurgist named Izod invented an impact test for determining the suitability of various metals to be used as cutting tools. The test involved a pendulum with a known weight at the end of its arm swinging down and striking the specimen as it stood clamped in a vertical position.

Some years later another metallurgist named Charpy modified the test slightly by orienting the specimen in a horizontal fashion. These pendulum impact test methods proved to be very useful, providing reliable, qualitative impact data throughout WWII up until the early 70's. It then became apparent that higher velocities and impact energies could be achieved with vertical style drop towers and thus the trend began to shift.

Pendulum machines remained popular with those testing to Izod and Charpy while more high speed, product oriented impact applications became the dominion of the drop tower.

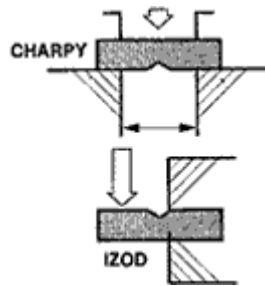

*Specimens for Charpy and Izod Testing*

While still used, pendulum impact testing has inherent weaknesses. In notched Izod testing, samples are mounted in a vise fixture with the notch facing a pendulum. A weighted pendulum, fixed at a point directly above the sample vise, is swung up and held stationary. This height and thus the speed of the pendulum at impact is a constant for this test. When released, the pendulum swings through the path where the sample is fixed. As the sample breaks, energy is absorbed by the sample. The height the pendulum attains after impact is measured by an indicator on a fixed scale which reads in joules (ft-lb). The impact strength is the loss of momentum in the pendulum while breaking the sample off at the notch.

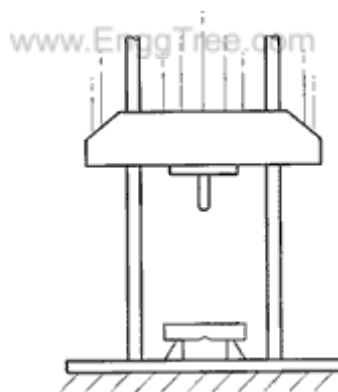

The Izod pendulum test configuration served as the standard in impact testing in the plastics and metals industry for many years. The problems with the Izod pendulum test involve several parameters which can drastically alter the results if not strictly controlled.

First the radius of the notch is critical. It is meant to simulate conditions which might exist in applications where the features such as internal corner on an enclosure will act as a stress concentrator upon impact. In a pendulum test, the radius cannot be varied. The notch radius has a significant effect on the ability of a sample to absorb impact. Most polymers, especially polycarbonate and nylon have critical notch radii below which their impact strength falls off dramatically. In a fixed radius test, the data can give a false

impression about the relative impact resistance of different polymers.

In addition, the creation of the notch in the sample has been a problem. Notch consistency has been difficult so comparison between testing labs is difficult. Notching blades can overheat polymers and degrade the material around the notch thus resulting in inaccurate test results. Industry round robin studies have shown that test results among participants were impossible to correlate because of the tremendous variations in notches.

A Charpy pendulum impact test is a variation of Izod. In a Charpy test, a sample is laid horizontally on two supports against an anvil. The sample is notched in the center and the notch side is positioned away from the pendulum. When the pendulum swings through the gap in the anvil, it impacts the center of the sample with a radiused hammer. The energy to break is measured and reported in the same way as with an Izod test.

### Hardness Test Rockwell

#### Hardness Test

The Rockwell hardness test method consists of indenting the test material with a diamond cone or hardened steel ball indenter. The indenter is forced into the test material under a preliminary minor load  $F_0$  (Fig. 1A) usually 10 kgf. When equilibrium has been reached, an indicating device, which follows the movements of the indenter and so responds to changes in depth of penetration of the indenter is set to a datum position. While the preliminary minor load is still applied an additional major load is applied with resulting increase in penetration (Fig. 1B). When equilibrium has again been reached, the additional major load is removed but the preliminary minor load is still maintained. Removal of the additional major load allows a partial recovery, so reducing the depth of penetration (Fig. 1C). The permanent increase in depth of penetration, resulting from the application and removal of the additional major load is used to calculate the Rockwell hardness number.

$$HR = E - e$$

$F_0$  = preliminary minor load in kgf  $F_1$  = additional major load in kgf  $F$  = total load in kgf  
 $e$  = permanent increase in depth of penetration due to major load  $F_1$  measured in units of 0.002 mm  $E$  = a constant depending on form of indenter: 100 units for diamond indenter, 130 units for steel ball indenter

$HR$  = Rockwell hardness number  $D$  = diameter of steel ball

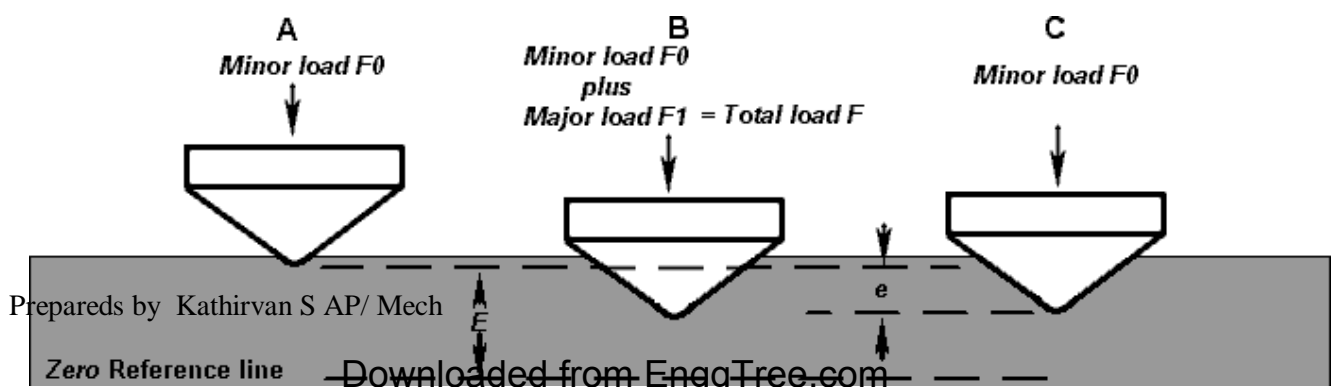

### Rockwell Principle

The Brinell hardness test method consists of indenting the test material with a 10 mm diameter hardened steel or carbide ball subjected to a load of 3000 kg. For softer materials the load can be reduced to 1500 kg or 500 kg to avoid excessive indentation. The full load is normally applied for 10 to 15 seconds in the case of iron and steel and for at least 30 seconds in the case of other metals. The diameter of the indentation left in the test material is measured with a low powered microscope. The Brinell hardness number is calculated by dividing the load applied by the surface area of the indentation.

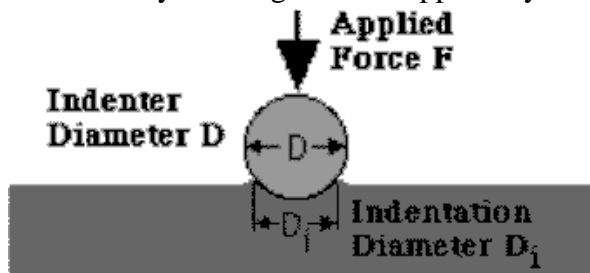

$$\text{BHN} = \frac{F}{\frac{\pi}{2} D \cdot (D - \sqrt{D^2 - D_i^2})}$$

The diameter of the impression is the average of two readings at right angles and the use of a Brinell hardness number table can simplify the determination of the Brinell hardness. A well structured Brinell hardness number reveals the test conditions, and looks like this, "75 HB 10/500/30" which means that a Brinell Hardness of 75 was obtained using a 10mm diameter hardened steel with a 500 kilogram load applied for a period of 30 seconds. On tests of extremely hard metals a tungsten carbide ball is substituted for the steel ball. Compared to the other hardness test methods, the Brinell ball makes the deepest and widest indentation, so the test averages the hardness over a wider amount of material, which will more accurately account for multiple grain structures and any irregularities in the uniformity of the material. This method is the best for achieving the bulk or macro-hardness of a material, particularly those materials with heterogeneous structures.

### Vickers Hardness Test

The Vickers hardness test method consists of indenting the test material with a diamond indenter, in the form of a right pyramid with a square base and an angle of 136 degrees between opposite faces subjected to a load of 1 to 100 kgf. The full load is normally applied for 10 to 15 seconds. The two diagonals of the indentation left in the surface of the material after removal of the load are measured using a microscope and their average calculated. The area of the sloping surface of the indentation is calculated. The Vickers hardness is the quotient obtained by dividing the kgf load by the square mm area of indentation.



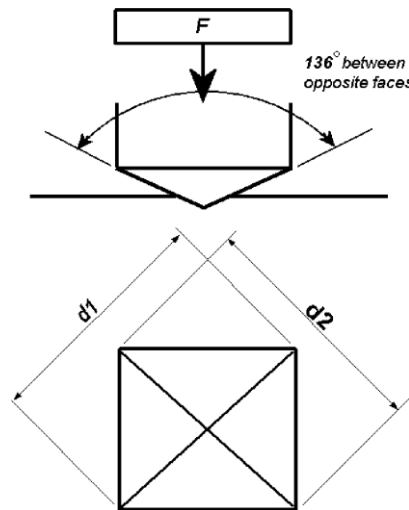

$F$  = Load in kgf

$d$  = Arithmetic mean of the two diagonals,  $d_1$  and  $d_2$  in mm HV = Vickers hardness

$$HV = \frac{2F \sin \frac{136^\circ}{2}}{d^2} \quad HV = 1.854 \frac{F}{d^2} \text{ approximately}$$

When the mean diagonal of the indentation has been determined the Vickers hardness may be calculated from the formula, but it is more convenient to use conversion tables. The Vickers hardness should be reported like 800 HV/10, which means a Vickers hardness of 800, was obtained using a 10 kgf force. Several different loading settings give practically identical hardness numbers on uniform material, which is much better than the arbitrary changing of scale with the other hardness testing methods. The advantages of the Vickers hardness test are that extremely accurate readings can be taken, and just one type of indenter is used for all types of metals and surface treatments. Although thoroughly adaptable and very precise for testing the softest and hardest of materials, under varying loads, the Vickers machine is a floor standing unit that is more expensive than the Brinell or Rockwell machines. There is now a trend towards reporting Vickers hardness in SI units (MPa or GPa) particularly in academic papers. Unfortunately, this can cause confusion. Vickers hardness (e.g. HV/30) value should normally be expressed as a number only (without the units kgf/mm<sup>2</sup>). Rigorous application of SI is a problem. Most Vickers hardness testing machines use forces of 1, 2, 5, 10, 30, 50 and 100 kgf and tables for calculating HV. SI would involve reporting force in newtons (compare 700 HV/30 to HV/294 N = 6.87 GPa) which is practically meaningless and messy to engineers and technicians.



Microhardness Test

The term microhardness test usually refers to static indentations made with loads not exceeding 1 kgf. The indenter is either the Vickers diamond pyramid or the Knoop elongated diamond pyramid. The procedure for testing is very similar to that of the standard Vickers hardness test, except that it is done on a microscopic scale with higher precision instruments. The surface being tested generally requires a metallographic finish; the smaller the load used, the higher the surface finish required. Precision microscopes are used to measure the indentations; these usually have a magnification of around X500 and measure to an accuracy of  $\pm 0.5$  micrometres. Also with the same observer differences of  $\pm 0.2$  micrometres can usually be resolved. It should, however, be added that considerable care and experience are necessary to obtain this accuracy.

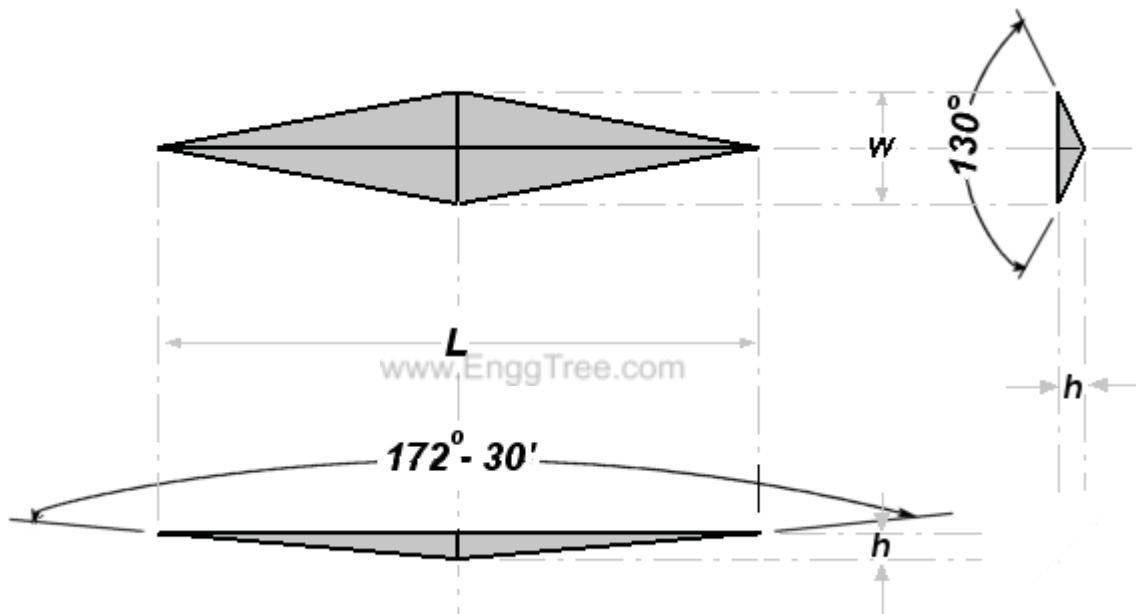

Knoop Hardness Indenter Indentation

The Knoop hardness number KHN is the ratio of the load applied to the indenter, P (kgf) to the

2  
 unrecovered projected area A (mm<sup>2</sup>)

$$KHN = F/A = P/CL$$

Where:

F = applied load in kgf

A = the unrecovered projected area of the indentation in mm<sup>2</sup> L = measured length of long diagonal of indentation in mm

C = 0.07028 = Constant of indenter relating projected area of the indentation to the square of the length of the long diagonal.

The Knoop indenter is a diamond ground to pyramidal form that produces a diamond shaped indentation having approximate ratio between long and short diagonals of 7:1. The depth of indentation is about 1/30 of its length. When measuring the Knoop hardness, only the longest diagonal of the indentation is measured and this is used in the above formula with the load used to calculate KHN. Tables of these values are usually a more convenient way to look-up KHN values from the measurements.

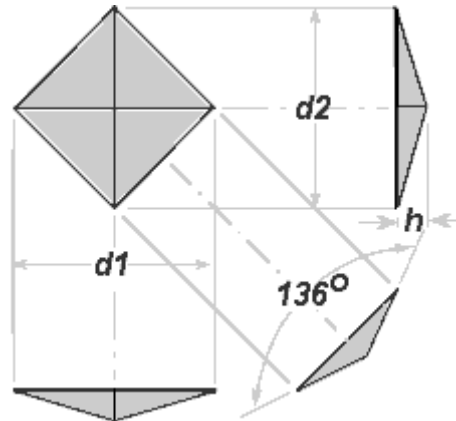

#### Vickers Pyramid Diamond Indenter Indentation

The Vickers Diamond Pyramid hardness number is the applied load (kgf) divided by the surface area

2

of the indentation (mm )

$$HV = \frac{2F \sin \frac{136^\circ}{2}}{d^2} \quad HV = 1.854 \frac{F}{d^2} \text{ approximately}$$

#### The Scleroscope Hardness Test

The Scleroscope test consists of dropping a diamond tipped hammer, which falls inside a glass tube under the force of its own weight from a fixed height, onto the test specimen. The height of the rebound travel of the hammer is measured on a graduated scale. The scale of the rebound is arbitrarily chosen and consists on Shore units, divided into 100 parts, which represent the average rebound from pure hardened high-carbon steel. The scale is continued higher than 100 to include metals having greater hardness.

In normal use the shore scleroscope test does not mark the material under test. The Shore Scleroscope measures hardness in terms of the elasticity of the material and the hardness

number depends on the height to which the hammer rebounds, the harder the material, the higher the rebound. Advantages of this method are portability and non-marking of the test surface.

### The Durometer

The Durometer is a popular instrument for measuring the indentation hardness of rubber and rubber- like materials. The most popular testers are the Model A used for measuring softer materials and the Model D for harder materials.

The operation of the tester is quite simple. The material is subjected to a definite pressure applied by a calibrated spring to an indenter that is either a cone or sphere and an indicating device measures the depth of indentation.

### Mohs Hardness Scale

The Mohs hardness scale for minerals has been used since 1822. It simply consists of 10 minerals arranged in order from 1 to 10. Diamond is rated as the hardest and is indexed as 10; talc as the softest with index number 1. Each mineral in the scale will scratch all those below it as follows:

Diamond	10
Corundum	9
Topaz	8
Quartz	7
Orthoclase (Feldspar)	6
Apatite	5
Fluorite	4
Calcite	3
Gypsum	2
Talc	1

The steps are not of equal value and the difference in hardness between 9 and 10 is much greater than between 1 and 2. The hardness is determined by finding which of the standard minerals the test material will scratch or not scratch; the hardness will lie between two points on the scale - the first point being the mineral which is scratched and the next point being the mineral which is not scratched. Some examples of the hardness of common metals in the Mohs scale are copper between 2 and 3 and tool steel between 7 and 8. This is a simple test, but is not exactly quantitative and the standards are purely

arbitrary numbers.

The materials engineer and metallurgist find little use for the Mohs scale, but it is possible to sub- divide the scale and some derived methods are still commonly used today. The file test is useful as a rapid and portable qualitative test for hardened steels, where convention hardness testers are not available or practical. Files can be tempered back to give a range of known hardness and then used in a similar fashion to the Mohs method to evaluate hardness.

### Creep

Creep may be defined as a time-dependent deformation at elevated temperature and constant stress. It follows, then, that a failure from such a condition is referred to as a creep failure or, occasionally, a stress rupture. The temperature at which creep begins depends on the alloy composition. For the common materials used in superheater and reheater construction, Table I (see below) gives the approximate temperatures for the onset of creep. It should be pointed out that the actual operating stress will, in part, dictate or determine the temperature at which creep begins.

The end of useful service life of the high-temperature components in a boiler (the superheater and reheater tubes and headers, for example) is usually a failure by a creep or stress-rupture mechanism. The root cause may not be elevated temperature, as fuel-ash corrosion or erosion may reduce the wall thickness so that the onset of creep and creep failures occur sooner than expected.

However, regardless of the cause, the failure will exhibit the characteristics of a creep or stress rupture. Indeed, the *ASME Boiler and Pressure Vessel Code* recognizes creep and creep deformation as high-temperature design limitations and provides allowable stresses for all alloys used in the creep range. One of the criteria used in the determination of these allowable stresses is 1% creep expansion, or deformation, in 100,000 hours of service. Thus, the code recognizes that over the operating life, some creep deformation is likely. And creep failures do display some deformation or tube swelling in the immediate region of the rupture.

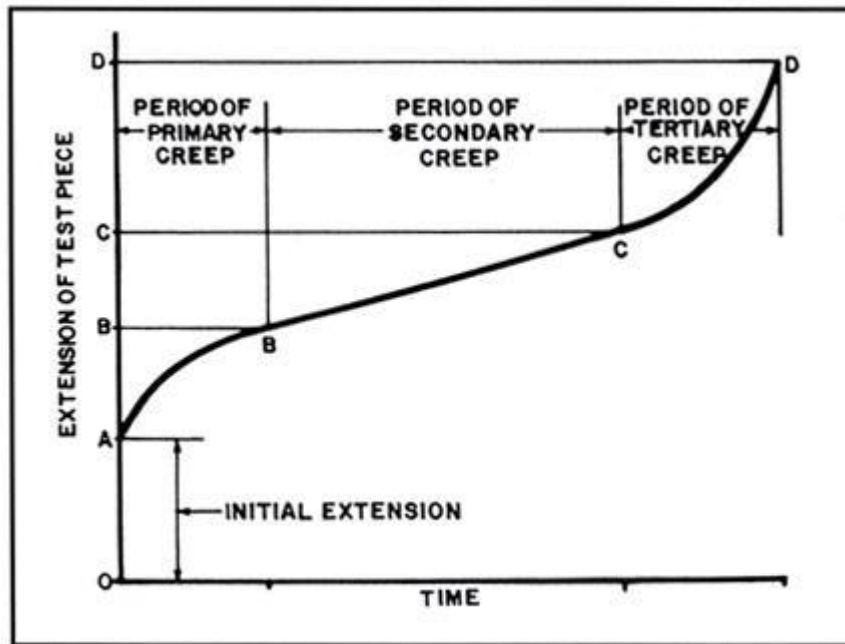

Figure 1. Schematic creep curve. Courtesy Babcock & Wilcox.

At elevated temperatures and stresses, much less than the high-temperature yield stress, metals undergo permanent plastic deformation called creep. Figure 1 shows a schematic creep curve for a constant load; a plot of the change in length versus time. The weight or load on the specimen is held constant for the duration of the test. There are four portions of the curve that are of interest:

[www.EnggTree.com](http://www.EnggTree.com)

- An initial steep rate that is at least partly of elastic origin, from point "O" to point "A" in Figure 1.
- This is followed by a region in which the elongation or deformation rate decreases with time, the so-called transient or primary creep, from region "A" to "B" of Figure 1. The portion from point "O" to point "B" occurs fairly quickly.
- The next portion of the creep curve is the area of engineering interest, where the creep rate is almost constant. The portion from "B" to "C" is nearly linear and predictable. Depending on the load or stress, the time can be very long; two years in a test and several decades in service.
- The fourth portion of the creep curve, beyond the constant-creep-rate or linear region, shows a rapidly increasing creep rate which culminates in failure. Even under constant-load test conditions, the effective stress may actually increase due to the damage that forms within the microstructure.

Without going into a detailed discussion of the atom movements involved in creep deformation, suffice it to say that creep deformation occurs by grain-boundary sliding. That is, adjacent grains or crystals move as a unit relative to each other. Thus, one of the

microstructural features of a creep failure is little or no obvious deformation to individual grains along the fracture edge.

The first two stages will not leave any microstructural evidence of creep damage. Somewhere along the linear portion of Figure 1, the first microstructural evidence of damage appears as individual voids or pores. The location of these first voids or holes varies, often noted at the junction of three or more grains, occasionally at nonmetallic inclusions. These individual voids grow and link to form cracks several grains long, and finally failure occurs. The ultimate rupture is by a tensile overload when effective wall thickness is too thin to contain the steam pressure.

Since creep deformation occurs by grain-boundary sliding, the more grain boundary area, the easier creep deformation will be. Creep deformation and creep strength are a grain-size sensitive property. Thus a larger grain size improves creep strength. For austenitic stainless steels, SA213 TP321H for example, the code requires a grain size of #7 or coarser, to assure adequate creep strength. The elevated temperatures where creep occurs lead to other microstructural changes. Creep damage and microstructural degradation occur simultaneously. For carbon steels and carbon-1/2 molybdenum steels, iron carbide will decompose into graphite. For the low-alloy steels of T-11 and T-22, the carbide phase spheroidizes. Thus, creep failures will include the degraded microstructures of graphite or spheroidized carbides along with the grain-boundary voids and cracks characteristic of these high-temperature, long-time failures.

While creep failures are expected for superheaters and reheaters operating at design conditions, deviations from these parameters will promote early failures. The steam temperature always varies some from individual tube to tube, and the design allows for this variability. However, when the range of temperatures is larger than accounted for, the hottest tubes fail sooner than expected. A more likely cause of premature failure is the slow increase in tube-metal temperatures due to the formation of the steam-side scale.

Steam reacts with steel to form iron oxide along the ID surface of the tube.

The microstructures themselves will show the grain-boundary sliding and the resultant creep cracks or voids. For stainless steels, the microstructures are similar in that the failure is by grain-boundary-sliding and crack formation.

In a superheater or reheater tube, often the very first sign of creep damage is longitudinal cracks in the steam-side scale. As creep deformation expands the tube diameter, the brittle ID scale cannot follow the expansion. Cracks develop in an axial or longitudinal direction which is perpendicular to the principle hoop stress. With time, the tube continues to expand, and these cracks widen. This wide crack shortens the path from steam to steel; iron oxide forms preferentially at the tip of the crack, as there is less oxide thickness to protect the steel; and a cusp forms within the steel tube. The cusp acts as a notch or a stress raiser, reducing the local wall thickness. Creep voids form here, often before any other obvious grain-boundary damage appears elsewhere within the microstructure. With continued high-



temperature operation, creep cracks grow from the cusp and ultimately weaken the cross section to the point where failure occurs.

Creep failures are characterized by:

Bulging or blisters in the tubethick-edged fractures often with very little obvious

ductilitylongitudinal "stress cracks" in either or both ID and OD oxide scales

external or internal oxide-scale thicknesses that suggest higher-than-expectedtemperatures

intergranular voids and cracks in the microstructure

The definition above refers to fracture "under repeated or fluctuating stresses having a maximum value less than the tensile strength." (The final fracture may have either brittle or ductile characteristics, depending upon the metal involved and the circumstances of the stress and the environment.)

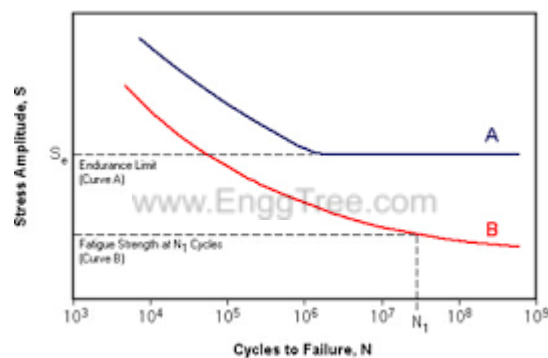

There are three stages of fatigue fracture: initiation, propagation, and final rupture. Indeed, this is the way that most authors refer to fatigue fracture, for it helps to simplify a subject that can become exceedingly complex.

Stage 1- Initiation. Initiation is the most complex stage of fatigue fracture and is the stage most rigorously studied by researchers. The most significant factor about the initiation stage of fatigue fracture is that the irreversible changes in the metal are caused by repetitive shear stresses. The accumulation of microchanges over a large number of load applications, called "cumulative damage," has been the subject of study over the years." (Obviously, if this stage can be prevented, there can be no fatigue fracture.) The initiation site of a given fatigue fracture is very small, never extending for more than two to five grains around the origin. At the location of a severe stress concentration, the number depends on the geometry of the part as well as on environmental, stress, metallurgical,

and strength conditions, as will become apparent.

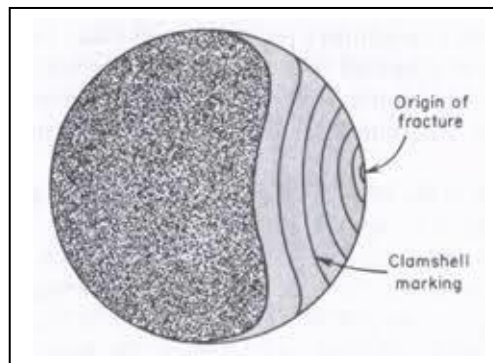

Stage 2 - Propagation. The propagation stage of fatigue causes the microcrack to change direction and grow perpendicular to the tensile stress. The second, or propagation, stage of fatigue is usually the most readily identifiable area of a fatigue fracture.

Stage 3 - Final Rupture. As the propagation of the fatigue crack continues, gradually reducing the cross-sectional area of the part or test specimen, it eventually weakens the part so greatly that final, complete fracture can occur with only one more load application. The fracture mode may be either ductile (with a dimpled fracture surface) or brittle (with a cleavage, or perhaps even intergranular, fracture surface) or any combination thereof, depending upon the metal concerned, the stress level, the environment, etc. Stage 3 represents the "last straw" that broke the camel's back, to borrow a metaphor.