

EE3014-POWER ELECTRONICS FOR RENEWABLE ENERGY SYSTEMS**UNIT I- INTRODUCTION****1.1 CLASSIFICATION OF ENERGY SOURCES****NON-CONVENTIONAL SOURCES/ RENEWABLE ENERGY SOURCES**

A plenty of energy is needed to sustain industrial growth and agricultural production. The existing sources of energy such as coal, oil, uranium etc. may not be adequate to meet the ever increasing energy demands. These conventional sources of energy are also depleting and may be exhausted at the end of the century or beginning of the next century. Consequently sincere and untiring efforts shall have to be made by the scientists and engineers in exploring the possibilities of harnessing energy from several non- conventional energy sources.

The various non-conventional energy sources are as follows:

1. Solar energy
2. Wind energy from biomass and biogas
3. Ocean thermal energy conversion
4. Tidal energy
5. Geothermal energy
6. Hydrogen energy
7. Fuel cells
8. Magneto-hydro-dynamic generator
9. Thermionic converter
10. Thermo-electric power.

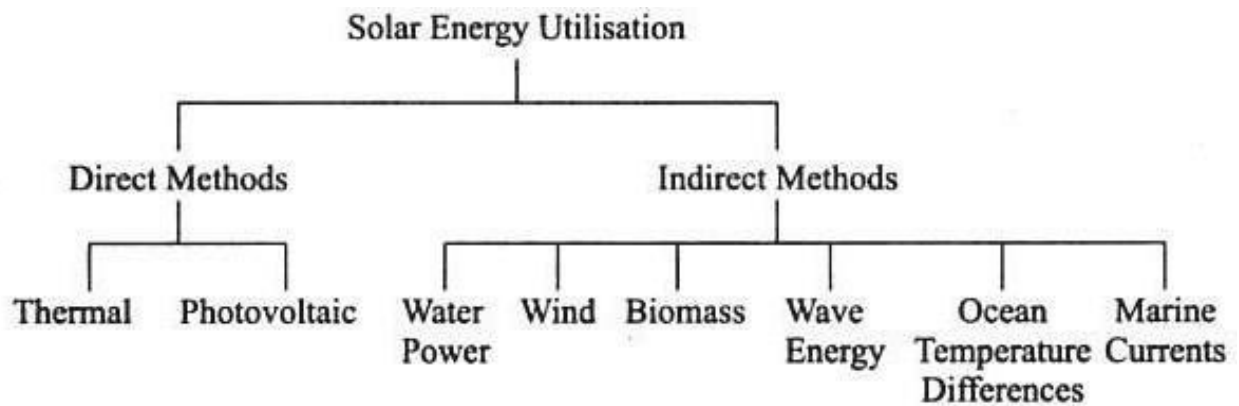

IMPORTANCE OF NON-CONVENTIONAL ENERGY SOURCES

MAN AND ENERGY:

- ENERGY is the ability to do work.
- ENERGY is the primary and most universal measure of all kind of work by human-beings and nature.
- Energy: It is the capability to produce motion, force, work, change in shape, change inform etc.

Energy exists in several forms such as:

- Chemical energy
- Nuclear energy
- Mechanical energy
- Electrical energy
- Internal energy
- Bio-energy in vegetables and animal bodies
- Thermal energy etc.

ADVANTAGES OF CONVECTIONAL/NON RENEWABLE ENERGY SOURCES

- Man has needed and used energy at an increasing rate for his sustenance and well- being ever since he came on the earth a few million years ago.
- Primitive man required energy primarily in the form of food.

He derived this by eating plants or animals which he hunted. Subsequently he discovered fire and his energy needs increased as he started to make use of wood and other biomass to supply the energy needs for cooking as well as for keeping himself warm.

- With the passage of time man started to cultivate land for agriculture. He added a new dimension to the use of energy by domesticating and training animals to work for him. With further demand for energy, man began to harness the wind for sailing ships and for driving windmills, and the force of falling water to turn waterwheels.

- Till this time, it would not be wrong to say that the sun was supplying all the energy needs of man either directly or indirectly and that man was using only renewable sources of energy. Advantages of convectional/non renewable energy sources

- The advantage of non-renewable energy is it's easy and cheap to use.

- There is no better way to store transfer and use energy than gasoline for powering motor vehicles.

- It's quick to pump fossil fuel into a car. It's stable in the tank and a gas tank hold quite a bit, and a gasoline powered car is cheap to manufacture.

- Coal is a ready-made fuel. It is relatively cheap to mine and to convert into energy. Coal supplies will last longer than oil or gas Oil is a ready-made fuel. Relatively cheap to mine and to convert into energy. It is a relatively cheap form of energy.

- Natural Gas is a ready-made fuel. It's as lightly cleaner fuel than coal or oil, emitting less carbon dioxide.

- Nuclear has a small amount of radioactive material produces a lot of energy. And raw material are relatively

cheap and can last quite a longtime. It doesn't give off atmospheric pollutants.

DISADVANTAGES OF CONVECTIONAL/NON RENEWABLE ENERGY SOURCES

- They leave behind harmful by-products upon combustion, thereby causing a lot of
- Pollution; mining of such fuels leads to irreversible damage to the adjoining environment.
 - Fossil fuels pollute the environment. They will eventually run out. Prices for fossil fuels are rising, especially if the real cost of their carbon is included. Burning fossil fuels produces carbon dioxide, a major cause of global warming.

EE3014-POWER ELECTRONICS FOR RENEWABLE ENERGY SYSTEMS**UNIT I- INTRODUCTION****1.2 ENVIRONMENTAL ASPECTS OF ELECTRIC ENERGY
CONVERSION****Coal as thermal fuel**

Coal is the raw fuel that provides 42% of the world's electricity. This distinguishes coal as the world's primary energy source for electricity generation. The name coal refers to a family of solid, organic fuels with different properties. Coal is mainly composed of elemental carbon and is formed by the conversion of deposited organic material. The lowest grade of coal formed is peat. Under the influence of high pressures and temperatures, the peat is transformed into coal. Using coal to generate power or heat is an old technique. The heat energy of these fuels is converted into mechanical energy by suitable prime movers such as steam engines, steam turbines, internal combustion engines etc.

Coal mining

There are two types of coal mining, strip mining and underground long wall mining. The environmental impacts from surface versus underground mining are not significantly different. The main difference between these two mining techniques is that the surface mining subsystem results in a higher amount of airborne ammonia emissions due to the production of ammonium nitrate explosives which are used at the mine. Another important difference is that underground mining requires limestone which emits a large amount of particulates during its production. The problematic pollutants in emission of coal based generating plants are Sulfur dioxide (SO_2), Nitrogen oxides (NO_x), carbon monoxide (CO) and carbon dioxide (CO_2) and certain hydrocarbons.

Oxides of sulphur (SO_2)

Most of the sulphur present in the fossil is oxidized to SO_2 in the combustion chamber before being emitted by the chimney. In atmosphere it gets further oxidized to H_2SO_4 and metallic sulphates which are the major source of concern as these can cause acid rain,

impaired visibility, damage to buildings and vegetation. Sulphate concentrations

of 9-20 $\mu\text{g}/\text{m}^3$ of air aggravate asthma, lung and heart disease.



Acidification

Acidification is one of the main problems arising from existing coal power. It takes place during many steps in the life cycle of electricity produced by coal combustion. Pumped mine water contains mud, dissolved sulphate and metal ions. It is also acidic and, therefore, needs to be neutralizing before being discharged. Drainage water from refuse piles with excavated and residual minerals can be very acidic, particularly if the rocks contain pyrite (ferric sulphide) that undergoes oxidation processes when exposed to the atmosphere. These oxidation processes take place in natural environments, but are greatly accelerated by mining activities, especially when no alkaline rocks are present to neutralize the acid formed.

Impact on biodiversity

The main environmental effect of electricity produced by coal combustion is probably related to the ubiquitous emission of greenhouse gases. The release to the atmosphere of such gases is larger from coal use than for any other fuel used for generating electricity. It is a general contention that any additional increase of greenhouse gases in the atmosphere will exacerbate global warming. This can lead to rapid changes in local weather conditions and can thus have many and profound influences on biodiversity. Organisms that cannot adapt or migrate successfully under changing climate conditions will be adversely affected.

ENVIRONMENT IMPACTS OF RENEWABLE ENERGY TECHNOLOGIES

Developing renewable energy technologies that exploit the sun, the wind, and geothermal energy is critical to addressing concerns about climate change and some environmental issues. However, using renewable energy sources will not eliminate all environmental concerns. Although renewable energy sources produce relatively low levels of Green House Gas emissions and conventional air pollution, manufacturing and transporting them will produce some emissions and pollutants. The production of some photovoltaic (PV) cells, for instance, generates toxic substances that may contaminate water resources. Renewable energy installations can also disrupt land use and wildlife habitat, and some technologies consume significant quantities of water.

To develop sound policies, policy makers must understand the relative environmental impacts of alternative energy sources, including how the impacts of renewable energy technologies compare to those of fossil-fuel technologies and to opportunities for improvements

in energy efficiency. Understanding the potential environmental impacts of renewable energy technologies is also essential for identifying and pursuing designs, manufacturing methods, project siting, utility operations, and so on to mitigate or offset these effects.



Life cycle uses of energy

For renewable energy sources, net energy ratio (NER) is expected to be greater than one, indicating a positive return over the fossil-fuel energy investment. For fossil-fuel and nuclear technologies, NERs are smaller than one and essentially represent the overall life cycle efficiency of the project. NERs are strongly influenced by a number of underlying assumptions, such as plant capacity and life expectancy. For electricity generation from wind and solar energy, the strength of the resource (which will affect the capacity factor of the installed technology) is also a critical assumption. For silicon PV specifically, the NER is highly dependent upon the thickness of the wafer and the efficiency of the cell/module produced. NERs would be significantly higher for waste biomass.

Local and regional air pollution

Most renewable energy technologies have much lower life cycle emissions of conventional air pollutants than conventional coal and natural gas plants. One exception is electricity generation from biomass, which can produce significant NO_x, particulate matter, and hazardous air pollutants, such as polycyclic aromatic hydrocarbons (PAHs). Although biomass has lower nitrogen content than fossil fuels, a substantial quantity of NO_x is formed whenever high-temperature combustion occurs in air, through oxidation of atmospheric nitrogen (N₂) at high temperatures. Although direct emissions of NO_x and SO_x are expected to be low for geothermal power plants, flash and dry-steam geothermal facilities can produce significant quantities of hydrogen sulfide (H₂S) from geothermal reservoirs, unless steps are taken to decrease it.

Land and water use

The amount of land used is a rough substitute for other impacts of new development, including impacts on ecosystems, cultural and historical resources, scenery, and agricultural land. When the impacts on land use are measured simply by the surface area they occupy during their life cycle, some renewable energy technologies appear to have heavy land-use requirements. However, this approach does not take into

account the intensity of land use or whether the technology allows for simultaneous use of land for other purposes. Whereas coal-fired power plants fully occupy the sites where they are constructed, small-scale PV installations

may be placed on rooftops where they cause little or no interference with the primary use of the land for commercial or residential buildings. Thus, smaller scale or distributed solar technologies may have less of an impact on land use and habitat loss than large-scale, central station plants. Land-use concerns may also be addressed by deploying renewable energy systems on previously developed sites, rather than in undeveloped areas.



Water is a scarce resource in large portions. Recent global circulation model projections suggest that, if climate change proceeds as expected, under current business-as-usual scenarios, freshwater supplies will become even scarcer in some parts of the world. Electricity production using thermoelectric technologies requires vast amounts of water, primarily for cooling. In is about 43 percent of existing thermoelectric generating capacity uses once-through cooling, 42 percent uses re-circulating wet towers, 14 percent uses re-circulating cooling ponds, and 1 percent uses dry cooling. Water use by power plants is characterized by withdrawals and consumption. Although consumption is sometimes emphasized over withdrawals, the latter is important, because power plant operation may be constrained by the amount of water available for withdrawal and power plant uses may compete with other demands for water. Furthermore, water returns can be significant sources of thermal pollution and may include discharges of chemical pollutants, such as chlorine or other biocides used in cooling towers.

ENVIRONMENT IMPACTS OF DIFFERENT RENEWABLE ENERGY SOURCES

All energy sources have some impact on our environment. Fossil fuels—coal, oil, and natural gas—do substantially more harm than renewable energy sources by most measures, including air and water pollution, damage to public health, wildlife and habitat loss, water use, land use, and global warming emissions. However, renewable sources such as wind, solar, geothermal, biomass, and hydropower *also* have environmental impacts, some of which are significant. The exact type and intensity of environmental impacts varies depending on the specific technology used, the geographic location, and a number of other factors. By understanding the current and potential environmental issues associated with each renewable energy source, we can take steps to effectively avoid or minimize these impacts as they become a larger portion of our electric supply.

Environmental impacts of wind energy

Land use

The land use impact of wind power facilities varies substantially depending on the site: wind turbines placed in flat areas typically use more land than those located in hilly areas. However, wind turbines do not occupy all of this land; they must be spaced approximately 5 to 10 rotor diameters apart (a rotor diameter is the diameter of the wind turbine blades). Thus, the turbines themselves and the surrounding infrastructure (including roads and transmission lines) occupy a small portion of the total area of a wind facility. Offshore wind facilities, require larger amounts of space because the turbines and blades are bigger than their land-based counterparts.



Wildlife and habitat

The impact of wind turbines on wildlife, most notably on birds and bats, has been widely documented and studied. A recent survey found evidence of bird and bat deaths from collisions with wind turbines and due to changes in air pressure caused by the spinning turbines, as well as from habitat disruption. Offshore wind turbines can have similar impacts on marine birds, but as with onshore wind turbines, the bird deaths associated with offshore wind are minimal. Wind farms located offshore will also impact fish and other marine wildlife.

Public health and community

Sound and visual impact are the two main public health and community concerns associated with operating wind turbines. Most of the sound generated by wind turbines is aerodynamic, caused by the movement of turbine blades through the air. There is also mechanical sound generated by the turbine itself. Overall sound levels depend on turbine design and wind speed. Some people living close to wind facilities have complained about sound and vibration issues. Under certain lighting conditions, wind turbines can create an effect known as shadow flicker. This annoyance can be minimized with careful siting, planting trees or installing window sunshades, or curtailing wind turbine operations when certain lighting conditions exist.

Water use

There is no water impact associated with the operation of wind turbines. As in all manufacturing processes, some water is used to manufacture steel and cement for wind turbines.

Life-cycle global warming emissions

While there are no global warming emissions associated with operating wind turbines, there are emissions associated with other stages of a wind turbine's life-cycle, including materials production, materials transportation, on-site construction and assembly, operation and

maintenance, and decommissioning and dismantlement. Estimates of total global warming emissions depend on a number of factors, including wind speed, percent of time the wind is blowing, and the material composition of the wind turbine.

Environmental impacts of solar energy systems

Land use

Depending on their location, larger utility-scale solar facilities can raise concerns about land degradation and habitat loss. Total land area requirements vary depending on the technology, the topography of the site, and the intensity of the solar resource. Estimates for utility-scale PV systems range from 3.5 to 10 acres per megawatt, while estimates for



concentrated solar power (CSP) facilities are between 4 and 16.5 acres per megawatt. Smaller scale solar PV arrays, which can be built on homes or commercial buildings, also have minimal land use impact.

Water use

Solar PV cells do not use water for generating electricity. However, as in all manufacturing processes, some water is used to manufacture solar PV components. Concentrating solar thermal plants (CSP), like all thermal electric plants, require water for cooling. Water use depends on the plant design, plant location, and the type of cooling system. CSP plants that use wet-recirculation technology with cooling towers withdraw between 600 and 650 gallons of water per megawatt-hour of electricity produced. CSP plants with once-through cooling technology have higher levels of water withdrawal, but lower total water consumption (because water is not lost as steam). Dry-cooling technology can reduce water use at CSP plants by approximately 90 percent. However, the exchanges to these water savings are higher costs and lower efficiencies.

Hazardous materials

The PV cell manufacturing process includes a number of hazardous materials, most of which are used to clean and purify the semiconductor surface. These chemicals, similar to those used in the general semiconductor industry, include hydrochloric acid, sulfuric acid, nitric acid, hydrogen fluoride, tri-chloroethane and acetone. The amount and type of chemicals used depends on the type of cell, the amount of cleaning that is needed, and the size of silicon wafer. Workers also face risks associated with inhaling silicon dust. Thus, PV manufacturers must follow the rules to ensure that workers are not harmed by exposure to these chemicals and that manufacturing waste products are disposed of properly.

Life-cycle global warming emissions

While there are no global warming emissions associated with generating electricity from solar energy, there are emissions associated with other stages of the solar life-cycle, including manufacturing, materials transportation, installation,

maintenance, and decommissioning and dismantlement. Most estimates of life-cycle emissions for photovoltaic systems are between 0.07 and 0.18 pounds of carbon dioxide equivalent per kilowatt-hour.

Environmental impacts of geothermal energy systems

Water quality and use

Geothermal power plants can have impacts on both water quality and consumption. Hot water pumped from underground reservoirs often contains high levels of sulfur, salt, and other



minerals. Most geothermal facilities have closed-loop water systems, in which extracted water is pumped directly, back into the geothermal reservoir after it has been used for heat or electricity production. In such systems, the water is contained within steel well casings cemented to the surrounding rock. Water is also used by geothermal plants for cooling and re-injection. Depending on the cooling technology used, geothermal plants can require between 1,700 and 4,000 gallons of water per megawatt-hour. However, most geothermal plants can use either geothermal fluid or freshwater for cooling; the use of geothermal fluids rather than freshwater clearly reduces the plants overall water impact.

Air emissions

The distinction between open- and closed-loop systems is important with respect to air emissions. In closed-loop systems, gases removed from the well are not exposed to the atmosphere and are injected back into the ground after giving up their heat, so air emissions are minimal. In contrast, open-loop systems emit hydrogen sulfide, carbon dioxide, ammonia, methane, and boron. Hydrogen sulfide, which has a distinctive -rotten egg smell, is the most common emission. Once in the atmosphere, hydrogen sulfide changes into sulfur dioxide (SO₂). This contributes to the formation of small acidic particulates that can be absorbed by the bloodstream and cause heart and lung disease. Sulfur dioxide also causes acid rain, which damages crops, forests, and soils, and acidifies lakes and streams. However, SO₂ emissions from geothermal plants are approximately 30 times lower per megawatt-hour than from coal plants.

Some geothermal plants also produce small amounts of mercury emissions, which must be mitigated using mercury filter technology. Scrubbers can reduce air emissions, but they produce a watery sludge composed of the captured materials, including sulfur, vanadium, silica compounds, chlorides, arsenic, mercury, nickel, and other heavy metals. This toxic sludge often must be disposed of at hazardous waste sites.

Land use

The amount of land required by a geothermal plant varies depending on the

properties of the resource reservoir, the amount of power capacity, the type of energy conversion system, the type of cooling system, the arrangement of wells and piping systems, and the substation and auxiliary building needs. The Geysers, the largest geothermal plant in the world, has a capacity of approximately 1,517 megawatts and the area of the plant is approximately 78 square kilometers, which translates to approximately 13 acres per megawatt. Like the Geysers, many geothermal sites are located in remote and sensitive ecological areas, so project developers must take this into account in their planning processes.



Life-cycle global warming emissions

In open-loop geothermal systems, approximately 10 percent of the air emissions are carbon dioxide and a smaller amount of emissions are methane, a more potent global warming gas. Estimates of global warming emissions for open-loop systems are approximately 0.1 pounds of carbon dioxide equivalent per kilowatt-hour. In closed-loop systems, these gases are not released into the atmosphere, but there are still some emissions associated with plant construction and surrounding infrastructure. Enhanced geothermal systems, which require energy to drill and pump water into hot rock reservoirs, have life-cycle global warming emission of approximately 0.2 pounds of carbon dioxide equivalent per kilowatt-hour. To put this into context, estimates of life-cycle global warming emissions for natural gas generated electricity are between 0.6 and 2 pounds of carbon dioxide equivalent per kilowatt-hour and estimates for coal-generated electricity are 1.4 and 3.6 pounds of carbon dioxide equivalent per kilowatt-hour.

Environmental impacts of hydroelectric energy systems

Land use

The size of the reservoir created by a hydroelectric project can vary widely, depending largely on the size of the hydroelectric generators and the topography of the land. Hydroelectric plants in flat areas tend to require much more land than those in hilly areas or canyons where deeper reservoirs can hold more volume of water in a smaller space. Flooding land for a hydroelectric reservoir has an extreme environmental impact: it destroys forest, wildlife habitat, agricultural land, and scenic lands.

Wildlife impacts

Dammed reservoirs are used for multiple purposes, such as agricultural irrigation, flood control, and recreation, so not all wildlife impacts associated with dams can be directly attributed to hydroelectric power. However, hydroelectric facilities can still have a major impact on aquatic ecosystems. For example, though there are a variety of methods to minimize the impact including fish ladders and in-take screens), fish and

other organisms can be injured and killed by turbine blades. Apart from direct contact, there can also be wildlife impacts both within the dammed reservoirs and downstream from the facility. Reservoir water is usually more stagnant than normal river water. As a result, the reservoir will have higher than normal amounts of sediments and nutrients, which can cultivate an excess of algae and other aquatic weeds. These weeds can crowd out other river animal and plant-life, and they must be controlled through manual harvesting or by introducing fish that eat these plants. In addition, water is lost through evaporation in dammed reservoirs at a much higher rate than in flowing rivers.



Life-cycle global warming emissions

Global warming emissions are produced during the installation and dismantling of hydroelectric power plants, but recent research suggests that emissions during a facility's operation can also be significant. Such emissions vary greatly depending on the size of the reservoir and the nature of the land that was flooded by the reservoir. Small run-of-the-river plants emit between 0.01 and 0.03 pounds of carbon dioxide equivalent per kilowatt-hour. Life-cycle emissions from large-scale hydroelectric plants built in semi-arid regions are also modest: approximately 0.06 pounds of carbon dioxide equivalent per kilowatt-hour. However, estimates for life-cycle global warming emissions from hydroelectric plants built in tropical areas are much higher. After the area is flooded, the vegetation and soil in these areas decomposes and releases both carbon dioxide and methane. The exact amount of emissions depends greatly on site-specific characteristics. However, current estimates suggest that life-cycle emissions can be over 0.5 pounds of carbon dioxide equivalent per kilowatt-hour.

Environmental IMPACTS of Biomass energy systems

Deforestation and land degradation

Biomass comprising traditional fuels constitutes about 50% of energy consumption in developing countries. Deforestation leading to soil erosion, risks of floods, desertification on account of clearing of forests and woodlands for agriculture and livestock, and so on, are the common concerns of environmentalists at macro levels. At a micro level, the concerns range from non-suitability of forest soils for agricultural purposes, health problems due to smoke caused by burning of fuel-wood, loss in soil fertility due to use of agricultural residues and so on. Even a shift towards non-wood biomass fuels creates direct competition with animals that rely upon crop remains and the plants for food. Imbalance between the demand and production of fuel-wood is reported to be one of the primary factors responsible for forest depletion. The increasing use of fuel-wood for meeting the domestic and industrial needs of both rural and urban areas has contributed to forest decline. The environmental impacts of urban fuel-wood consumption have been severe

due to commercial exploitation of fuel-wood for charcoal production. The demand for charcoal in urban areas has spread deforestation, which begins at the surrounding areas of urban centres and moving outwards.

Loss of soil nutrients

Agricultural residues constitute an important source of energy in rural areas of developing countries when left on fields improves the fertility of the soil. The use of agricultural residues for energy would thus be an issue if it reduces the fertility of the soil. It is important to note that all residues do not have the same effect on the soil. Some residues such as corncobs, rice husk, jute sticks, cotton stock, coffee pruning, and coconut shells do not decompose easily



and have potential as energy sources. The choice of agricultural residues thus has an impact on the environment. Cattle dung, similarly, though it is a fertilizer, loses its value as fertilizer if burnt or left under the sun for a few days. The two categories of residues from agriculture sector are crop residue and cattle dung. Currently crop residue of cereals is largely used as food and woody residues are used as fuel. Burning of woody crop residue may not lead to any significant loss of nutrients to soil. Burning of cattle dung as fuel leads to loss of organic matter and other nutrients affecting crop production.

Environmental impacts of tidal energy systems

Understanding environmental impacts

In spite of the many benefits of exploiting tidal power, there are negative impacts, as well. For example, the risk to the marine environment and marine mammals is largely unknown. In order to operate tidal power stations appropriately and analyze the potential contribution tidal power can make in terms of renewable energy, we must better understand the environmental impacts of this technology. One important mention is the difference between environmental effects and environmental impacts. On one hand, environmental effects refer to the wide range of potential interactions between tidal energy equipment and the marine ecosystems. On the other hand, environmental impacts are those particular effects that we know for sure will cause deleterious ecological alterations.

Environmental impacts of Tidal energy

In many ways, the environmental impacts of harnessing tidal power are similar to those of offshore wind power generation. Several assessments over the past few years have identified the following potential environmental impacts. These indirect ecological impacts would result from lengthy installation of offshore renewable energy projects.

- ❖ Changing of substrates, sediment transit and deposition;
- ❖ Alteration of waves and sea currents;
- ❖ Noise pollution during installation and operation;
- ❖ Alteration of ecosystems for regional organisms;

- ❖ Emission of harmful electromagnetic fields;
- ❖ Intrusion upon animal migrations; and
- ❖ Potential strikes by any moving parts of the tidal system.

Environmental impacts of Hydrogen-based energy systems

There is increasing interest in the role that hydrogen-based energy systems may play in the future, especially in the transport sector. They appear to be an attractive alternative to current fossil fuel-based energy systems in the future, since these have been proven to affect climate due



to greenhouse gases emissions. However, any future hydrogen-based economy would need to assess the possible global environmental impacts of such alternative energy production. Emissions of hydrogen lead to increased burdens of methane and ozone and hence to an increase in global warming. Therefore, hydrogen can be considered as an indirect greenhouse gas with the potential to increase global warming. The scientists have estimated that the potential effects on climate from hydrogen-based energy systems would be much lower than those from fossil fuel-based energy systems. However, such impacts will depend on the rate of hydrogen leakage during its synthesis, storage and use. The researchers have calculated that a global hydrogen economy with a leakage rate of 1% of the produced hydrogen would produce a climate impact of 0.6% of the fossil fuel system it replaces. If the leakage rate was 10%, then the climate impact would be 6% of that of the fossil fuel system.

Environmental Impacts of Hydrokinetic Energy systems

Hydrokinetic energy, which includes wave and tidal power, encompasses an array of energy technologies, many of which are still in the experimental stages or in the early stages of deployment. While actual impacts of large-scale operations have not been observed, a range of potential impacts can be projected. For example, wave energy installations can require large expanses of ocean space, which could compete with other uses—such as fishing and shipping—and cause damage to marine life and habitats. Some tidal energy technologies are located at the mouths of ecologically-sensitive estuary systems, which could cause changes in hydrology and salinity that negatively impact animal and plant life.

Greenhouse gas emissions (GHG)

Compared to fossil-fuel-based electricity generation, renewable energy technologies offer a major advantage in lower emissions of CO₂ and other GHGs. In addition, all forms of renewable electricity production are expected to have significantly lower life cycle GHG emissions than electricity production from conventional coal and natural gas plants. Renewable energy would have less of an advantage if carbon capture

and sequestration were included with fossil-fuel power plants, or if energy storage systems, such as battery energy storage, compressed air energy storage, or pumped hydro storage, were included as part of renewable energy systems. GHG emissions for some renewable technologies are difficult to estimate. For example, emissions from bio-power vary, depending on which feedstock is used and the assumptions about their production. Most CO₂ emission (CO_{2e}) values for bio-power range from 15 to 52 g CO_{2e}/kWh for biomass derived from cultivated feed-stocks, excluding emissions associated with initial land conversion. If carbon capture and storage were added to bio-power systems, there would also be large reductions in CO_{2e} values.





EE3014-POWER ELECTRONICS FOR RENEWABLE ENERGY SYSTEMS**UNIT1-INTRODUCTION****1.3-QUALITATIVE STUDY OF DIFFERENT RENEWABLE ENERGYRESOURCES****Solar energy*****Concentrating solar power (CSP) technologies***

Concentrating Solar Power (CSP) technologies use mirrors to concentrate (focus) the sun's light energy and convert it into heat to create steam to drive a turbine that generates electrical power. CSP technology utilizes focused sunlight. CSP plants generate electric power by using mirrors to concentrate (focus) the sun's energy and convert it into high-temperature heat. That heat is then channeled through a conventional generator. The plants consist of two parts: one that collects solar energy and converts it to heat, and another that converts the heat energy to electricity.

Solar photovoltaic technology basics

Solar cells, also called photovoltaic (PV) cells by scientists, convert sunlight directly into electricity. PV gets its name from the process of converting light (photons) to electricity (voltage), which is called the PV effect. Traditional solar cells are made from silicon, are usually flat-plate, and generally are the most efficient. Second-generation solar cells are called thin-film solar cells because they are made from amorphous silicon or non-silicon materials such as cadmium telluride. Thin film solar cells use layers of semiconductor materials only a few micrometers thick. Because of their flexibility, thin film solar cells can double as rooftop shingles and tiles, building facades, or the glazing for skylights. Third-generation solar cells are being made from a variety of new materials besides silicon, including solar inks using conventional printing press technologies, solar dyes, and conductive plastics. Some new solar cells use plastic lenses or mirrors to concentrate sunlight onto a very small piece of high efficiency PV material. The PV material is more expensive, but because so little is needed, these systems are becoming cost effective for use by utilities and industry.

Solar PV array module

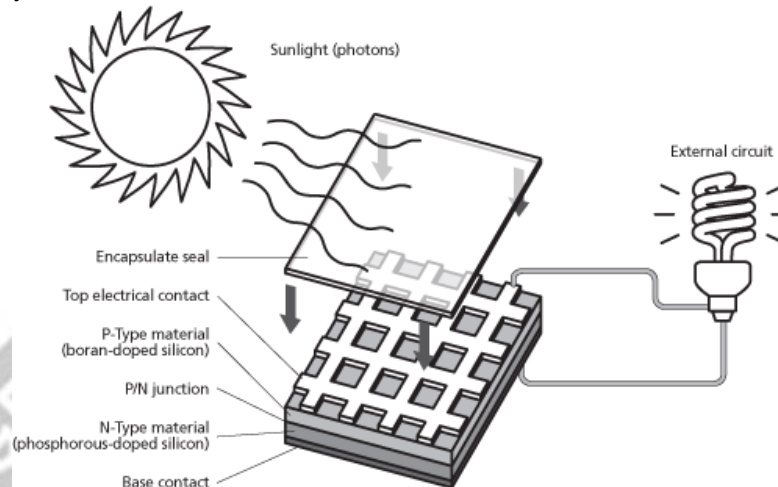

Construction and Working of PV / Solar Cell

The basic element of a PV System is the photovoltaic (PV) cell, also called a Solar Cell. An example of a PV / Solar Cell made of Mono-crystalline Silicon. This single PV / Solar Cell are like a square but with its four corners missing (it is made this way). A PV / Solar Cell is a semiconductor device that can convert solar energy into DC electricity through the Photovoltaic effect (Conversion of solar light energy into electrical energy). When light shines on a PV / Solar Cell, it may be reflected, absorbed, or passes right through. But only the absorbed light generates electricity.

PV module / panel and PV array

To increase their utility, a number of individual PV cells are interconnected together in a sealed, weatherproof package called a Panel (Module). For example, a 12 V Panel (Module) will have 36 cells connected in series and a 24 V Panel (Module) will have 72 PV Cells connected in series To achieve the desired voltage and current, Modules are wired in series and parallel into what is called a PV Array. The flexibility of the modular PV system allows designers to create solar power systems that can meet a wide variety of electrical needs.

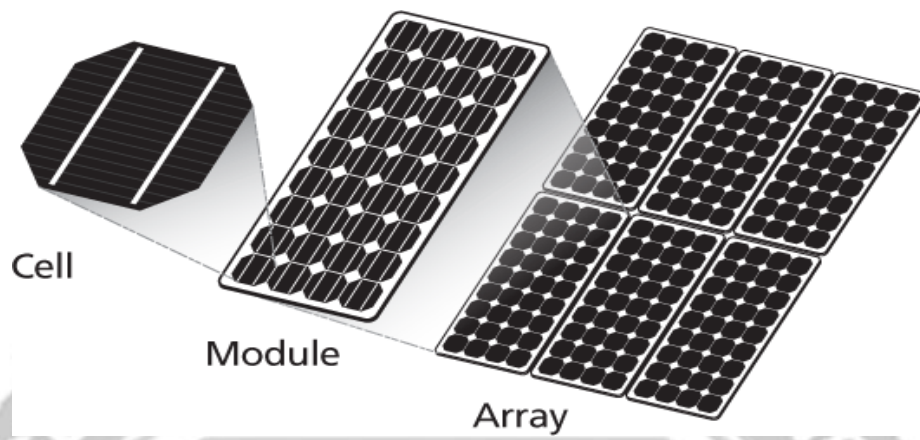

PV Cell, Module and Array

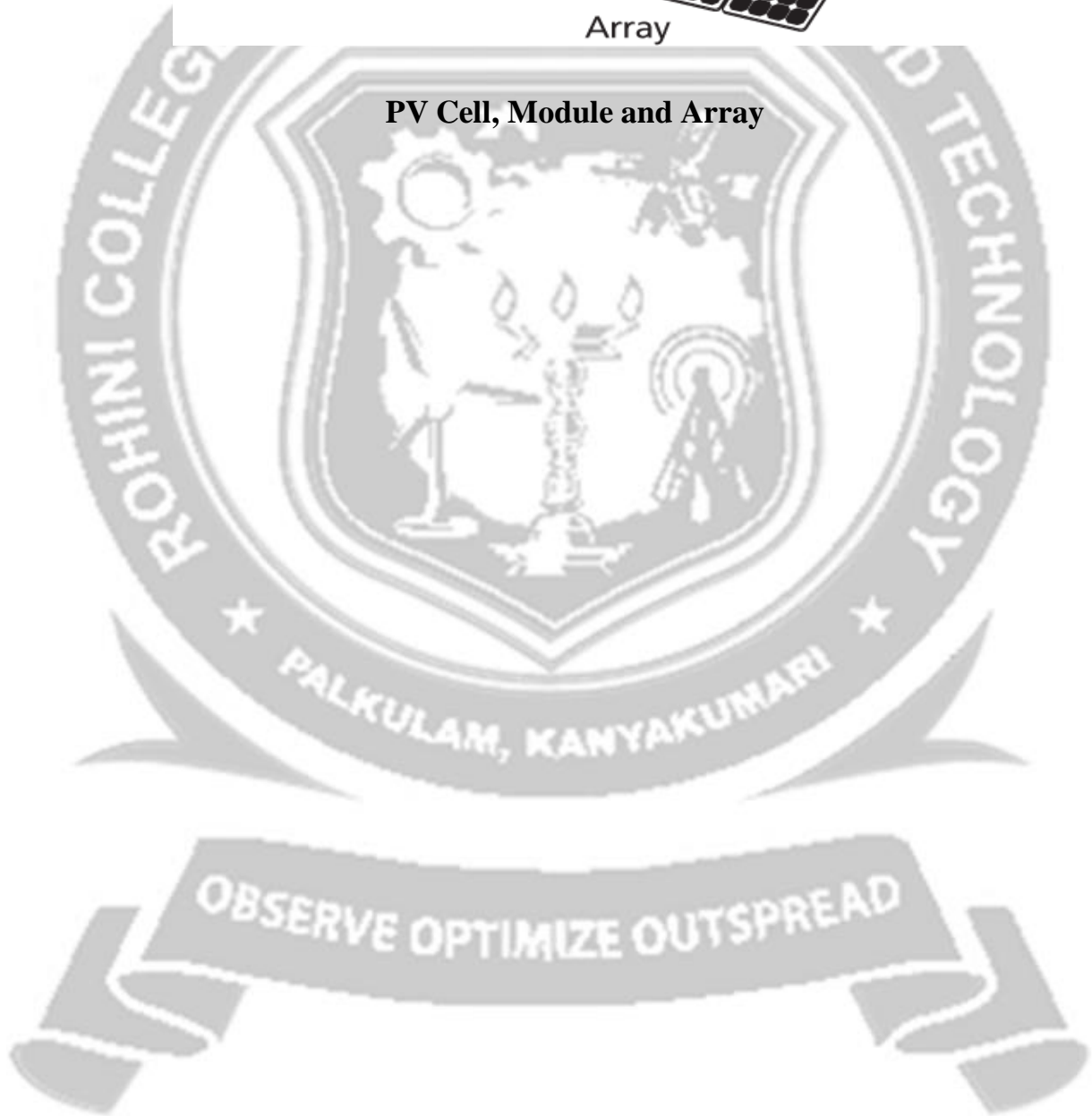

The cells are very thin and fragile so they are sandwiched between a transparent front sheet, usually glass, and a backing sheet, usually glass or a type of tough plastic. This protects them from breakage and from the weather. An aluminum frame is fitted around the module to enable easy fixing to a support structure.

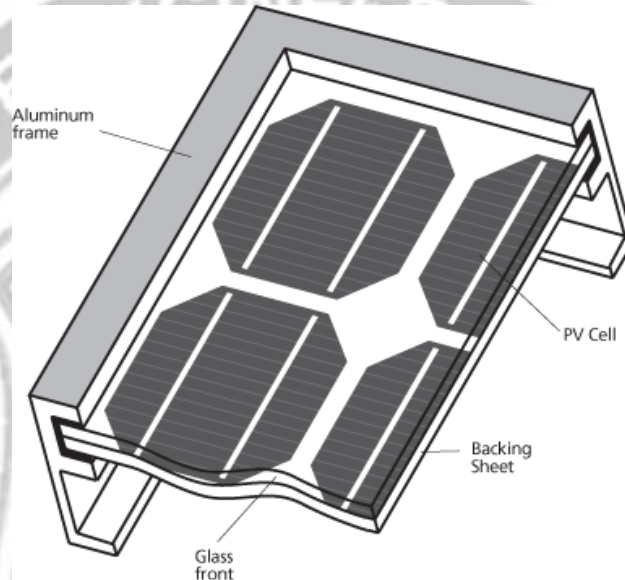

Construction of a typical Mono-crystalline PV / Solar Panel

Bypass diodes

As mentioned, PV / Solar cells are wired in series and in parallel to form a PV / Solar Panel (Module). The number of series cells indicates the voltage of the Panel (Module), whereas the number of parallel cells indicates the current. If many cells are connected in series, shading of individual cells can lead to the destruction of the shaded cell or of the lamination material, so the Panel (Module) may blister and burst. To avoid such an operational condition, Bypass Diodes are connected anti-parallel to the solar cells as in Figure. As a result, larger voltage differences cannot arise in the reverse-current direction of the solar cells. In practice, it is sufficient to connect one bypass diode for every 15-20 cells. Bypass diodes also allow current to flow through the PV module when it is partially shaded, even if at a reduced voltage and power. Bypass diodes do not cause any losses, because under normal operation, current does not flow

through them.

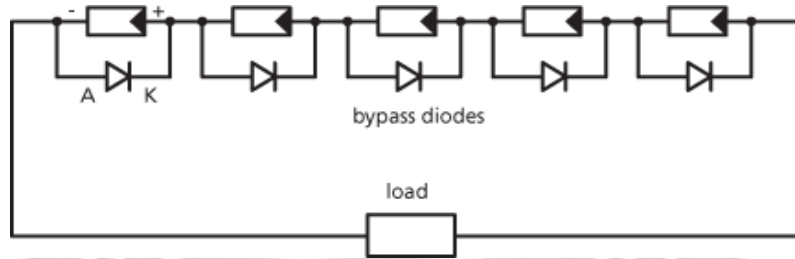

Parallel PV cell with bypass diodes

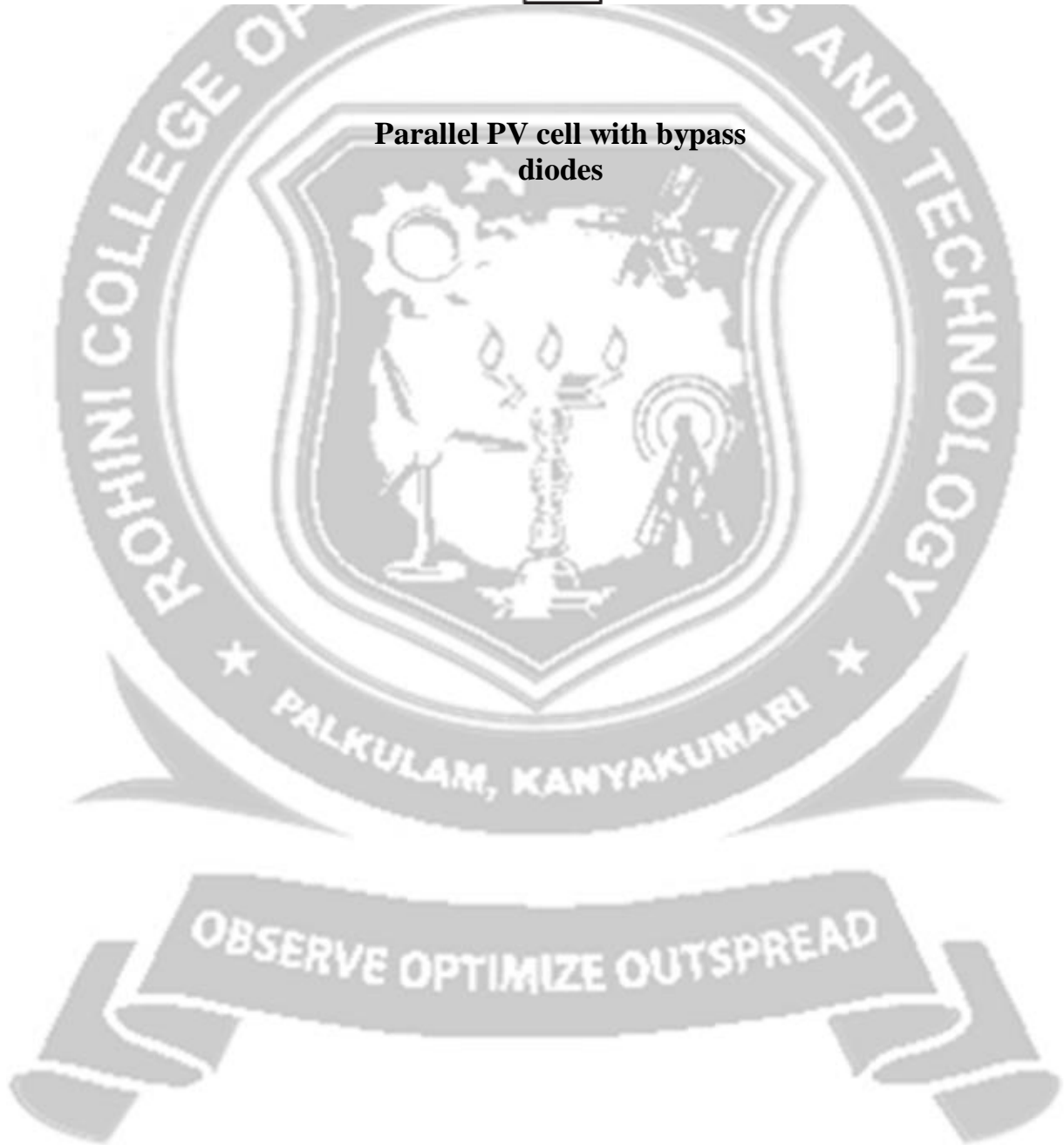

Photovoltaic Power Systems

Photovoltaic (PV) technology converts one form of energy (sunlight) into another form of energy (electricity) using no moving parts, consuming no conventional fossil fuels, creating no pollution, and lasting for decades with very little maintenance. The use of a widely available and reasonably reliable fuel source—the sun—with no associated storage or transportation difficulties and no emissions makes this technology eminently practicable for powering remote scientific research platforms. The completely profitable nature of the technology also lends itself well to varying power requirements—from the smallest autonomous research platforms to infrastructure-based systems. Based on semiconductor technology, solar cells operate on the principle that electricity will flow between two semiconductors when they are put into contact with each other and exposed to light (photons). This phenomenon is known as the photovoltaic effect.

Wind energy

Wind energy is energy from moving air, caused by temperature (and therefore pressure) differences in the atmosphere. Irradiance from the sun heats up the air, forcing the air to rise. Conversely, where temperatures fall, a low pressure zone develops. Winds (i.e. air flows) balance out the differences. Hence, wind energy is solar energy converted into kinetic energy of moving air.

Characteristics

As the wind power is proportional to the cubic wind speed, it is crucial to have detailed knowledge of the site-specific wind characteristics. Even small errors in estimation of wind speed can have large effects on the energy yield, but also lead to poor choices for turbine and site. An average wind speed is not sufficient. Site-specific wind characteristics related to wind turbines include:

- Mean wind speed: Only interesting as a headline figure, but does not tell how often high wind speeds occur.

- Wind speed distribution : diurnal, seasonal, annual patterns
- Turbulence: short-term fluctuations
- Long-Term Fluctuations
- Distribution Of Wind Direction
- Wind Shear (Profile)



Wind turbine types

Horizontal Axis Wind Turbines (HAWT)

Horizontal axis wind turbines, also shortened to HAWT, are the common style that most of us think of when we think of a wind turbine. A HAWT has a similar design to a windmill; it has blades that look like a propeller that spin on the horizontal axis. Horizontal axis wind turbines have the main rotor shaft and electrical generator at the top of a tower, and they must be pointed into the wind. Small turbines are pointed by a simple wind vane placed square with the rotor (blades), while large turbines generally use a wind sensor coupled with a servo motor to turn the turbine into the wind. Most large wind turbines have a gearbox, which turns the slow rotation of the rotor into a faster rotation that is more suitable to drive an electrical generator.

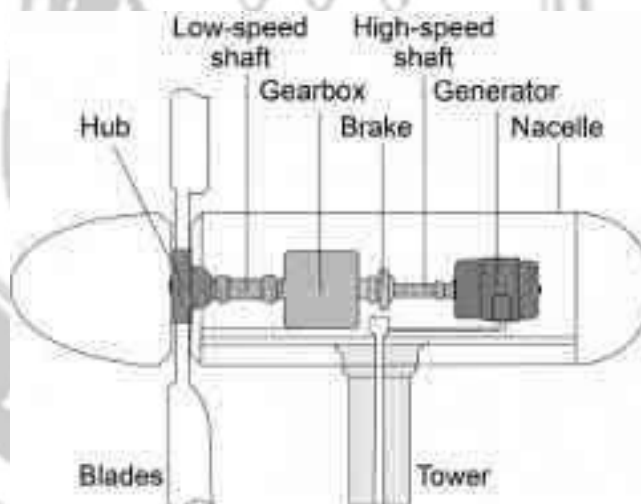

Horizontal Axis Wind Turbine

Since a tower produces turbulence behind it, the turbine is usually pointed upwind of the tower. Wind turbine blades are made stiff to prevent the blades from being pushed into the tower by high winds. Additionally, the blades are placed a considerable distance in front of the tower and are sometimes tilted up a small amount.

Advantages

- The tall tower base allows access to stronger wind in sites with wind shear.

- High efficiency since the blades always moves perpendicularly to the wind, receiving power through the whole rotation.
- In contrast, all vertical axis wind turbines, and most proposed airborne wind turbine designs, involve various types of reciprocating actions, requiring airfoil surfaces to backtrack against the wind for part of the cycle.
- Backtracking against the wind leads to inherently lower efficiency.



Disadvantages

- ❑ Massive tower construction is required to support the heavy blades, gearbox, and generator.
- ❑ Components of a horizontal axis wind turbine (gearbox, rotor shaft and brake assembly) being lifted into position.
- ❑ Their height makes them obtrusively visible across large areas, disrupting the appearance of the landscape and sometimes creating local opposition.
- ❑ HAWTs require an additional yaw control mechanism to turn the blades toward the wind.

Vertical Axis Wind Turbines (VAWT)

Vertical axis wind turbines, as shortened to VAWTs, have the main rotor shaft arranged vertically. The main advantage of this arrangement is that the wind turbine does not need to be pointed into the wind. This is an advantage on sites where the wind direction is highly variable or has turbulent winds. With a vertical axis, the generator and other primary components can be placed near the ground, so the tower does not need to support it, also makes maintenance easier. The main drawback of a VAWT generally creates drag when rotating into the wind.

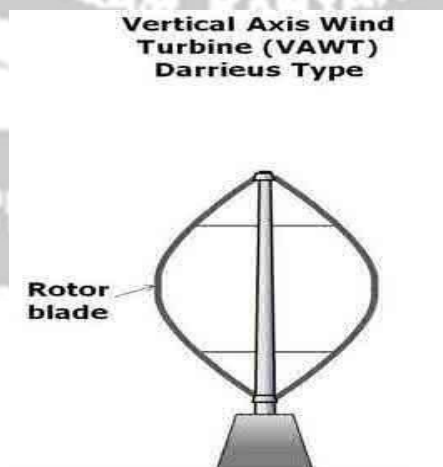

Vertical Axis Wind Turbine

It is difficult to mount vertical-axis turbines on towers, meaning they are often installed nearer to the base on which they rest, such as the ground or a building rooftop. The wind speed is slower at a lower altitude, so less wind energy is available for a given size turbine. Air flow near the ground and other objects can create turbulent flow, which can introduce issues of vibration, including noise and bearing wear which may increase the maintenance or shorten its service life. However, when a turbine is mounted on a rooftop, the building generally redirects wind over the roof and these can double the wind speed at the turbine. If the height of the rooftop mounted turbine tower is approximately 50% of the building height, this is near the optimum for maximum wind energy and minimum wind turbulence.



Advantages

- No yaw mechanisms are needed.
- A VAWT can be located nearer the ground, making it easier to maintain the moving parts.
- VAWTs have lower wind startup speeds than the typical the HAWTs.
- VAWTs may be built at locations where taller structures are prohibited.
- VAWTs situated close to the ground can take advantage of locations where rooftops, mesas, hilltops, ridgelines, and passes funnel the wind and increase wind velocity.

Disadvantages

- Most VAWTs have an average decreased efficiency from a common HAWT, mainly because of the additional drag that they have as their blades rotate into the wind.
- Versions that reduce drag produce more energy, especially those that funnel wind into the collector area.
- Having rotors located close to the ground where wind speeds are lower and do not take advantage of higher wind speeds above.

Component of a wind turbine

Rotor

The part of the wind turbine that collects energy from the wind is called the rotor. The rotor usually consists of two or more wooden, fiberglass or metal blades which rotate about an axis (horizontal or vertical) at a rate determined by the wind speed and the shape of the blades. The blades are attached to the hub, which in turn is attached to the main shaft.

Drag Design

Blade designs operate on either the principle of drag or lift. For the drag design,

the wind literally pushes the blades out of the way. Drag powered wind turbines are characterized by slower rotational speeds and high torque capabilities. They are useful for the pumping, sawing or grinding work. For example, a farm-type windmill must develop high torque at start-up in order to pump, or lift, water from a deep well.



Lift Design

The lift blade design employs the same principle that enables airplanes, kites and birds to fly. The blade is essentially an airfoil, or wing. When air flows past the blade, a wind speed and pressure differential is created between the upper and lower blade surfaces. The pressure at the lower surface is greater and thus acts to "lift" the blade. When blades are attached to a central axis, like a wind turbine rotor, the lift is translated into rotational motion. Lift-powered wind turbines have much higher rotational speeds than drag types and therefore well suited for electricity generation.

Tip Speed Ratio

The tip-speed is the ratio of the rotational speed of the blade to the wind speed. The larger this ratio, the faster the rotation of the wind turbine rotor at a given wind speed. Electricity generation requires high rotational speeds. Lift-type wind turbines have maximum tip-speed ratios of around 10, while drag-type ratios are approximately 1. Given the high rotational speed requirements of electrical generators, it is clear that the lift-type wind turbine is most practical for this application.

Generator

The generator is what converts the turning motion of a wind turbine's blades into electricity. Inside this component, coils of wire are rotated in a magnetic field to produce electricity. Different generator designs produce either alternating current (AC) or direct current (DC), and they are available in a large range of output power ratings. The generator's rating, or size, is dependent on the length of the wind turbine's blades because more energy is captured by longer blades. It is important to select the right type of generator to match your intended use. Most home and office appliances operate on 120 volt (or 240 volt), 60 cycle AC. Some appliances can operate on either AC or DC, such as light bulbs and resistance heaters, and many others can be adapted to run on DC. Storage systems using batteries store DC and usually are configured at voltages of between 12 volts and 120 volts. Generators that produce AC are generally equipped with features to produce the correct voltage (120 or 240 V) and constant frequency (60

cycles) of electricity, even when the wind speed is fluctuating.



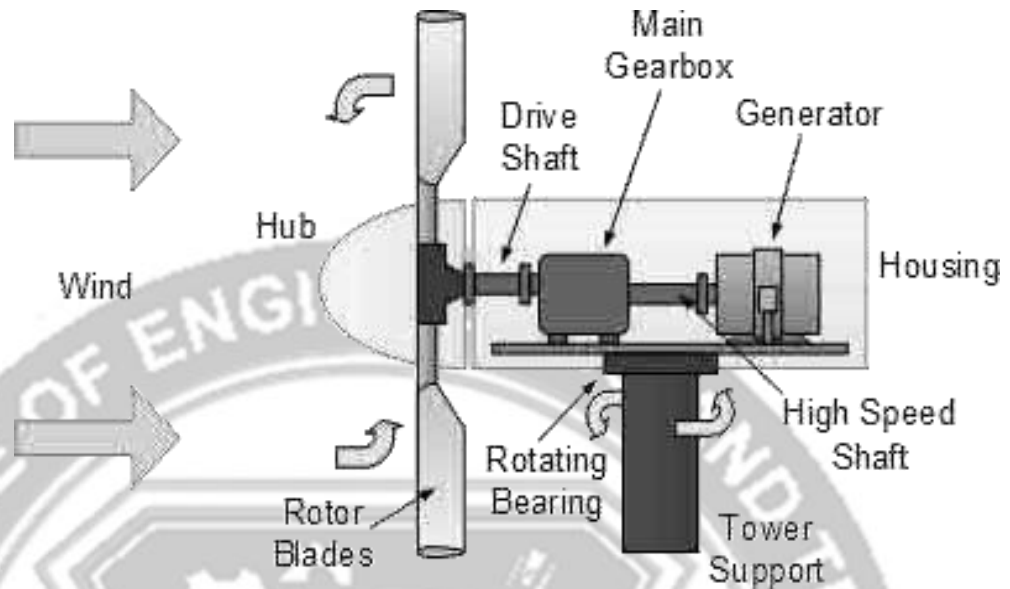

Components of a wind turbine

Transmission

The number of revolutions per minute (rpm) of a wind turbine rotor can range between 40 rpm and 400 rpm, depending on the model and the wind speed. Generators typically require rpm's of 1,200 to 1,800. As a result, most wind turbines require a gear-box transmission to increase the rotation of the generator to the speeds necessary for efficient electricity production. Some DC-type wind turbines do not use transmissions. Instead, they have a direct link between the rotor and generator. These are known as direct drive systems. Without a transmission, wind turbine complexity and maintenance requirements are reduced, but a much larger generator is required to deliver the same power output as the AC-type wind turbines.

Towers

The tower on which a wind turbine is mounted is not just a support structure. It also raises the wind turbine so that its blades safely clear the ground and so it can reach the stronger winds at higher elevations. Maximum tower height is optional in most cases, except where zoning restrictions apply. The decision of what height tower to use will be based on the cost of taller towers versus the value of the increase in energy

production resulting from their use.

ADVANTAGES AND DISADVANTAGES OF WIND POWER

ADVANTAGES

- The wind is free and with modern technology it can be captured efficiently.
- Once the wind turbine is built the energy it produces does not cause green housegases or other pollutants.



- Although wind turbines can be very tall each takes up only a small plot of land.
- Many people find wind farms an interesting feature of the landscape.
- Remote areas that are not connected to the electricity power grid can use windturbines to produce their own supply.

DISADVANTAGES

- More noise
- Threatening to Wildlife.
- Wind is Unpredictable.
- Limited Resource.
- Inefficient.
- Poor Television Reception.
- Installation Cost is high.

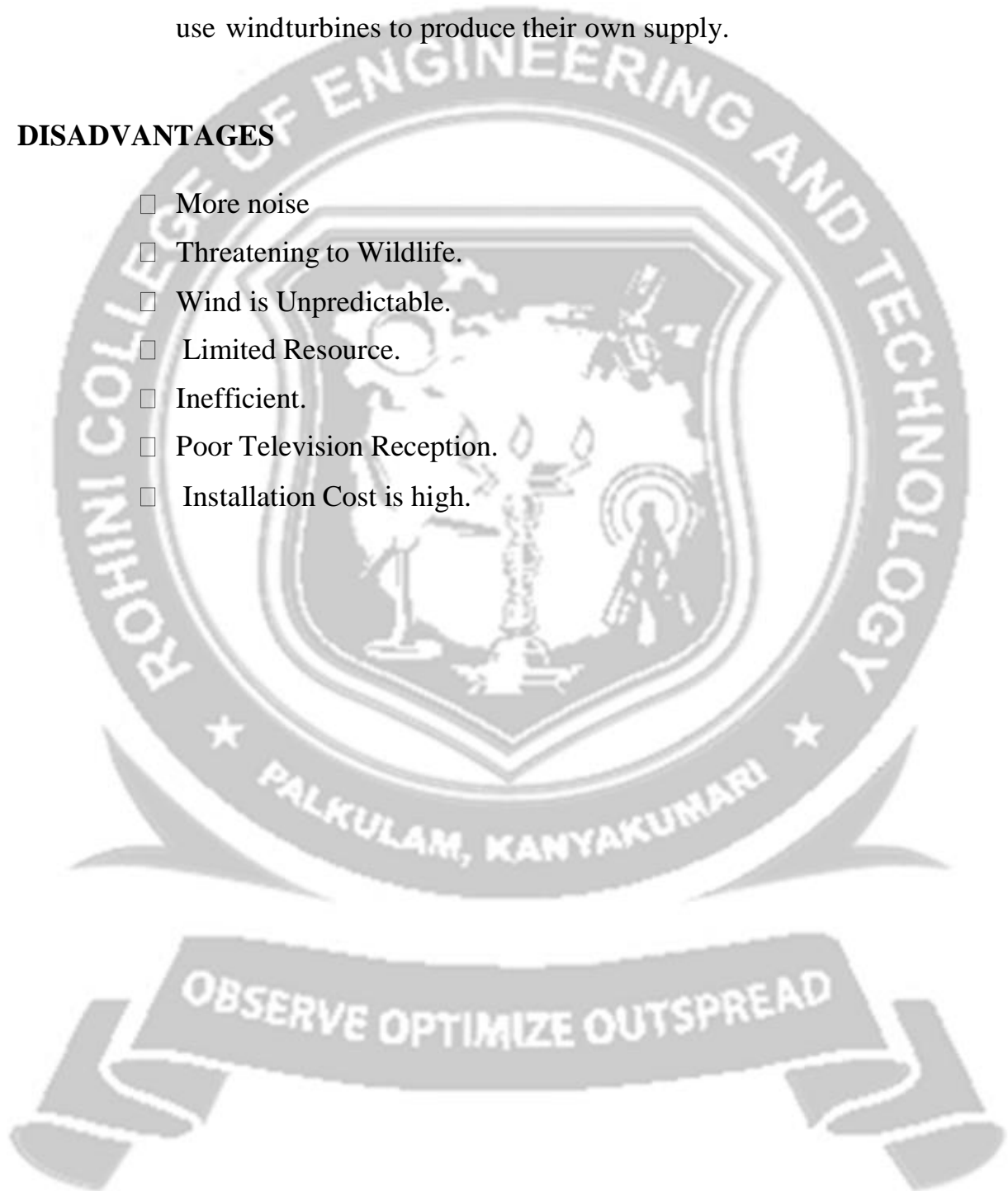

EE3014-POWER ELECTRONICS FOR RENEWABLE ENERGY SYSTEMS**UNIT1-INTRODUCTION****1.4 QUALITATIVE STUDY OF DIFFERENT RENEWABLE ENERGY RESOURCES: OCEAN, BIOMASS, FUEL CELL.****Ocean Power****Tidal Energy Generation**

Tidal energy, just like hydro energy transforms water in motion into a clean energy. The motion of the tidal water, driven by the pull of gravity, contains large amounts of kinetic energy in the form of strong tidal currents called tidal streams. The daily ebbing and flowing, back and forth of the oceans tides along a coastline and into and out of small inlets, bays or coastal basins, is little different to the water flowing down a river or stream. The movement of the sea water is harnessed in a similar way using waterwheels and turbines to that used to generate hydro electricity. But because the sea water can flow in both directions in a tidal energy system, it can generate power when the water is flowing in and also when it is ebbing out. Therefore, tidal generators are designed to produce power when the rotor blades are turning in either direction. However, the costs of reversible electrical generators are more expensive than single direction generators.

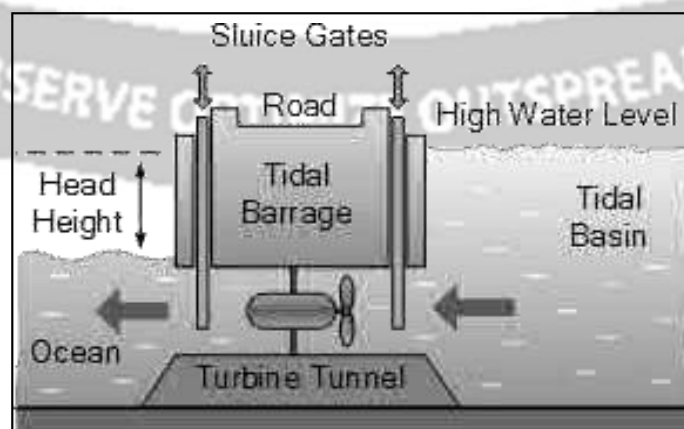
Different Types of Tidal Energy Systems**Tidal Barrage**

Tidal Barrage:

A Tidal Barrage is a type of tidal power generation that involves the construction of a fairly low dam wall, known as a -barragell and hence its name, across the entrance of a tidal inlet or basin creating a tidal reservoir. This dam has a number of underwater tunnels cut into its width allowing sea water to flow through them in a controllable way using -sluice gatesll. Fixed within the tunnels are huge water turbine generators that spin as the water rushes past them generating tidal electricity. Tidal barrages generate electricity using the difference in the vertical height between the incoming high tides and the outgoing low tides. As the tide ebbs and flows, sea water is allowed to flow in or out of the reservoir through a one way underwater tunnel system. This flow of tidal water back and forth causes the water turbine generators located within the tunnels to rotate producing tidal energy with special generators used to produce electricity on both the incoming and the outgoing tides.

Tidal Stream



TIDAL STREAM

A Tidal Stream Generation system reduces some of the environmental effects of tidal barrages by using turbine generators under the surface of the water. Major tidal flows and ocean currents, like the Gulf Stream, can be exploited to extract its tidal energy using underwater rotors and turbines. Tidal stream generation is very similar in principal to wind power generation, except this time water currents flow across turbines

rotor blades which rotates the turbine, much like how wind currents turn the blades for wind power turbines. In fact, tidal stream generation areas on the sea bed can look just like underwater wind farms. Tidal streams are formed by the horizontal fast flowing volumes of water caused by the ebb and flow of the tide as the profile of the sea bed causes the water to speed up as it approaches the shoreline.

Advantages and disadvantages of Tidal Energy

Advantages

- Tidal energy is a renewable energy resource because the energy it produces is free and clean as no fuel is needed and no waste by-products are produced.
- Tidal energy has the potential to produce a great deal of free and green energy.
- Tidal energy is not expensive to operate and maintain compared to other forms of renewable energies.
- Low visual impact as the tidal turbines are mainly if not totally submerged beneath the water.
- Low noise pollution as any sound generated is transmitted through the water.
- Tidal barrages provide protection against flooding and land damage.
- Large tidal reservoirs have multiple uses and can create recreational lakes and areas where before there were none.

Disadvantages of Tidal Energy

- Tidal energy is not always a constant energy source as it depends on the strength and flow of the tides which themselves are affected by the gravitational effects of the moon and the sun.
- Tidal Energy requires a suitable site, where the tides and tidal streams are consistently strong.
- Must be able to withstand forces of nature resulting in high capital, construction and maintenance costs.
- High power distribution costs to send the generated power from the

submerged devices to the land using long underwater cables.

- Danger to fish and other sea-life as they get stuck in the barrage or sucked through the tidal turbine blades.



Wave energy

Waves are caused by the wind blowing over the surface of the ocean. In many areas of the world, the wind blows with enough consistency and force to provide continuous waves along the shoreline. Ocean waves contain tremendous energy potential. Wave power devices extract energy from the surface motion of ocean waves or from pressure fluctuations below the surface. Wave power varies considerably in different parts of the world. While an abundance of wave energy is available, it cannot be fully harnessed everywhere for a variety of reasons, such as other competing uses of the ocean (i.e. shipping, commercial fishing, naval operations) or environmental concerns in sensitive areas. Therefore, it is important to consider how much resource is recoverable in a given region.

Ocean thermal energy conversion (OTLC)

Closed-Cycle of OTLC

Closed-cycle systems use fluids with a low boiling point, such as ammonia, to rotate a turbine to generate electricity. Warm surface seawater is pumped through a heat exchanger, where the low-boiling-point fluid is vaporized. The expanding vapor turns the turbo-generator. Cold deep seawater—which is pumped through a second heat exchanger—then condenses the vapor back into a liquid that is then recycled through the system.

Open-Cycle of OTLC

Open-cycle systems use the tropical oceans' warm surface water to make electricity. When warm seawater is placed in a low-pressure container, it boils. The expanding steam drives a low-pressure turbine attached to an electrical generator. The steam, which has left its salt behind in the low-pressure container, is almost pure, fresh water. It is condensed back into a liquid by exposure to cold temperatures from deep-ocean water.

Hybrid OTLC

Hybrid systems combine the features of closed- and open-cycle systems. In a hybrid system, warm seawater enters a vacuum chamber, where it is flash-evaporated into steam, similar to the open-cycle evaporation process. The steam vaporizes a low-boiling-point fluid (in a closed-cycle loop) that drives a turbine to produce electricity.

Complementary Technologies

OTEC has potential benefits beyond power production. For example, spent cold seawater from an OTEC plant can chill fresh water in a heat exchanger or flow directly into a cooling system. OTEC technology also supports chilled-soil agriculture. When cold seawater flows through underground pipes, it chills the surrounding soil. The temperature difference between



plant roots in the cool soil and plant leaves in the warm air allows many plants that evolved in temperate climates to be grown in the subtropics.

Biomass power plants

The most common types of boilers are hot water boilers and steam boilers. Wood chips, residues and other types of biomass are used in the boilers, in the same way as coal, natural gas and oil. Fuel is stored in a bunker for further transport to the boiler. In the boiler, water is heated to high temperature under pressure. Steam from the boiler powers the turbine, which is connected to the generator. Steam has passed through the turbine, heats area heating water, which is distributed through the area heating network's piping. Co-firing biomass with coal (replacing a portion of coal with biomass) is an effective method of using biomass for energy purposes and to reduce CO₂ emissions. Coal plants can be made suitable to replace part of the coal by biomass or even to convert fully to biomass – turning a coal plant into a 100% renewable energy plant.

Biomass used for electricity generation

Forest products: Woody biomass from multi-functional forests constitutes the majority of today's biomass. Pellets and briquettes are manufactured by compressing by-products from the forestry industry, such as sawdust, bark or small diameter wood. They are easy to transport and therefore suitable for export.

Waste, by-products and residues: Residues include manure, sewage, sludge and other degradable waste. Liquid biomass waste, such as manure, household waste and sewage plant residues, can be digested to biogas.

Energy crops: Energy crops are not used on a large scale for electricity or heat production today. As demand for sustainable biomass increases over time, such energy crops may play a more important role in the future. Examples include woody short rotation forestry/crops such as eucalyptus, poplar and willow. But also herbaceous (grassy) energy crops such as miscanthus can be used. Especially with the use of energy crops, it is important to ensure these plantations are established and managed in a

sustainable manner.

Fuel cell

Fuel cell is a device that uses hydrogen (or hydrogen-rich fuel) and oxygen to create electricity by an electrochemical process. A single fuel cell consists of an electrolyte sandwiched between two thin electrodes (a porous anode and cathode). Hydrogen, or a hydrogen-rich fuel, is fed to the anode where a catalyst separates hydrogen's negatively charged electrons from positively charged ions (protons). At the cathode, oxygen combines with electrons and, in some cases, with species such as protons or water, resulting in water or hydroxide ions, respectively.



The electrons from the anode side of the cell cannot pass through the membrane to the positively charged cathode; they must travel around it via an electrical circuit to reach the other side of the cell. This movement of electrons is an electrical current. The amount of power produced by a fuel cell depends upon several factors, such as fuel cell type, cell size, the temperature at which it operates, and the pressure at which the gases are supplied to the cell.



EE3014-POWER ELECTRONICS FOR RENEWABLE ENERGY SYSTEMS**UNIT I- INTRODUCTION****1.5: QUALITATIVE STUDY OF DIFFERENT RENEWABLE ENERGY RESOURCES:
HYDROGEN ENERGY SYSTEMS AND HYBRID RENEWABLE ENERGY SYSTEMS.****Hydrogen energy**

Hydrogen can be considered as a clean energy carrier similar to electricity. Hydrogen can be produced from various domestic resources such as renewable energy and nuclear energy. In the long-term, hydrogen will simultaneously reduce the dependence on foreign oil and the emission of greenhouse gases and other pollutants.

Hydrogen as an Energy Carrier

Hydrogen is considered as a secondary source of energy, commonly referred to as an energy carrier. Energy carriers are used to move, store and deliver energy in a form that can be easily used. Electricity is the most well-known example of an energy carrier. Hydrogen as an important energy carrier in the future has a number of advantages. For example, a large volume of hydrogen can be easily stored in a number of different ways. Hydrogen is also considered as a high efficiency, low polluting fuel that can be used for transportation, heating, and power generation in places where it is difficult to use electricity. In some instances, it is cheaper to ship hydrogen by pipeline than sending electricity over long distances by wire.

Hydrogen Fuel Cell

Fuel cells directly convert the chemical energy in hydrogen to electricity, with pure water and heat as the only byproducts. Hydrogen-powered fuel cells are not only pollution-free, but a two to three fold increase in the efficiency can be experienced when compared to traditional combustion technologies.

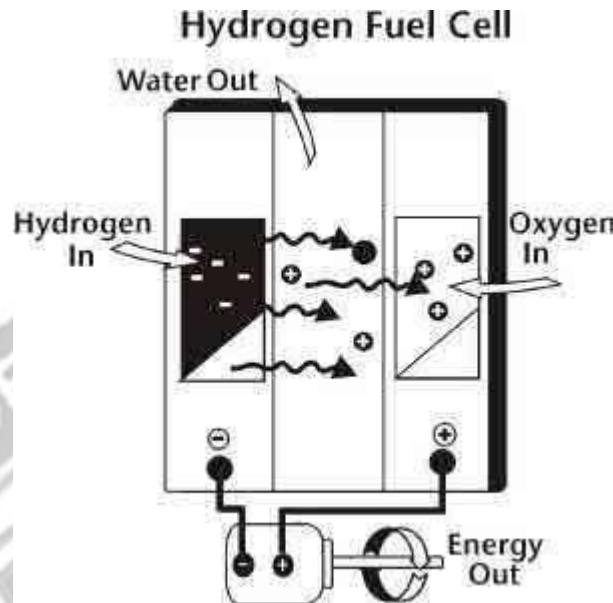

Hydrogen Fuel Cell

Fuel cells can power almost any portable devices that normally use batteries. Fuel cells can also power transportation such as vehicles, trucks, buses, and marine vessels, as well as provide auxiliary power to traditional transportation technologies. Hydrogen can play a particularly important role in the future by replacing the imported petroleum we currently use in our cars and trucks.

HYBRID RENEWABLE ENERGY SYSTEMS

Environmentally friendly power generation technologies will play an important role in future power supply. The renewable energy technologies include power generation from renewable energy sources, such as wind, PV(photovoltaic), MH(micro hydro), biomass, ocean wave, geothermal and tides. In general, the key reason for the deployment of the above energy systems are their benefits, such as supply security, reduced carbon emission, improved power quality, reliability and employment opportunity to the local people. Since the renewable energy resources are intermittent in nature therefore, hybrid combinations of two or more power generation technologies, along with storage can improve system performance. Hybrid Renewable Energy System (HRES) combines two or more renewable energy resources with some conventional source (diesel or petrol generator) along with storage, in order to fulfill the

demand of an area. The intensity of the different energy sources into time is not the same. In general, when one of the sources is intensive, the other tends to be extensive, i.e. the sources complement one another. The distribution into time and the intensity of the energy sources depend on the meteorological conditions of the chosen area, on the season, on the relief, etc. The following definition of a hybrid system with renewable energy sources can be suggested. This is a power system, using one renewable and one conventional energy source or more than one renewable with or without conventional energy sources, that works in -stand alone or -grid connected mode.

Hybrid Wind and Solar Electric Systems

A hybrid renewable energy system utilizes two or more energy production methods, usually solar and wind power. The major advantage of solar / wind hybrid system is that when solar and wind power production is used together, the reliability of the system is enhanced. Additionally, the size of battery storage can be reduced slightly as there is less reliance on one method of power production. Often, when there is no sun, there is plenty of wind. It is ideally suited to remote homes, schools and other off-grid applications. They can also be retrofitted to existing diesel-generator systems to save on high fuel costs and minimize noise.

Because the peak operating times for wind and solar systems occur at different times of the day and year, hybrid systems are more likely to produce power when need it. Many hybrid systems are stand-alone systems, which operate "off-grid" -- not connected to an electricity distribution system. For the times when neither the wind nor the solar system are producing, most hybrid systems provide power through batteries and/or an engine generator powered by conventional fuels, such as diesel. If the batteries run low, the engine generator can provide power and recharge the batteries. Adding an engine generator makes the system more complex, but modern electronic controllers can operate these systems automatically. An engine generator can also reduce the size of the other components needed for the system. Keep in mind that the storage capacity must be large enough to supply electrical needs during non-charging periods. Battery banks

are typically sized to supply the electric load for one to three days. Since hybrid systems include both solar and wind power, they allow the power user to benefit from the advantages provided of both forms of energy.



Advantages of Hybrid Energy System

- Reductions in size of diesel engine and battery storage system, which can save the fuel and reduce pollution.
- Improves the load factors and help saving on maintenance and replacement costs.
- The cost of electricity can be reduced by integrating diesel systems with renewable power generation.
- Renewable hybrid energy systems can reduce the cost of high-availability renewable energy systems.

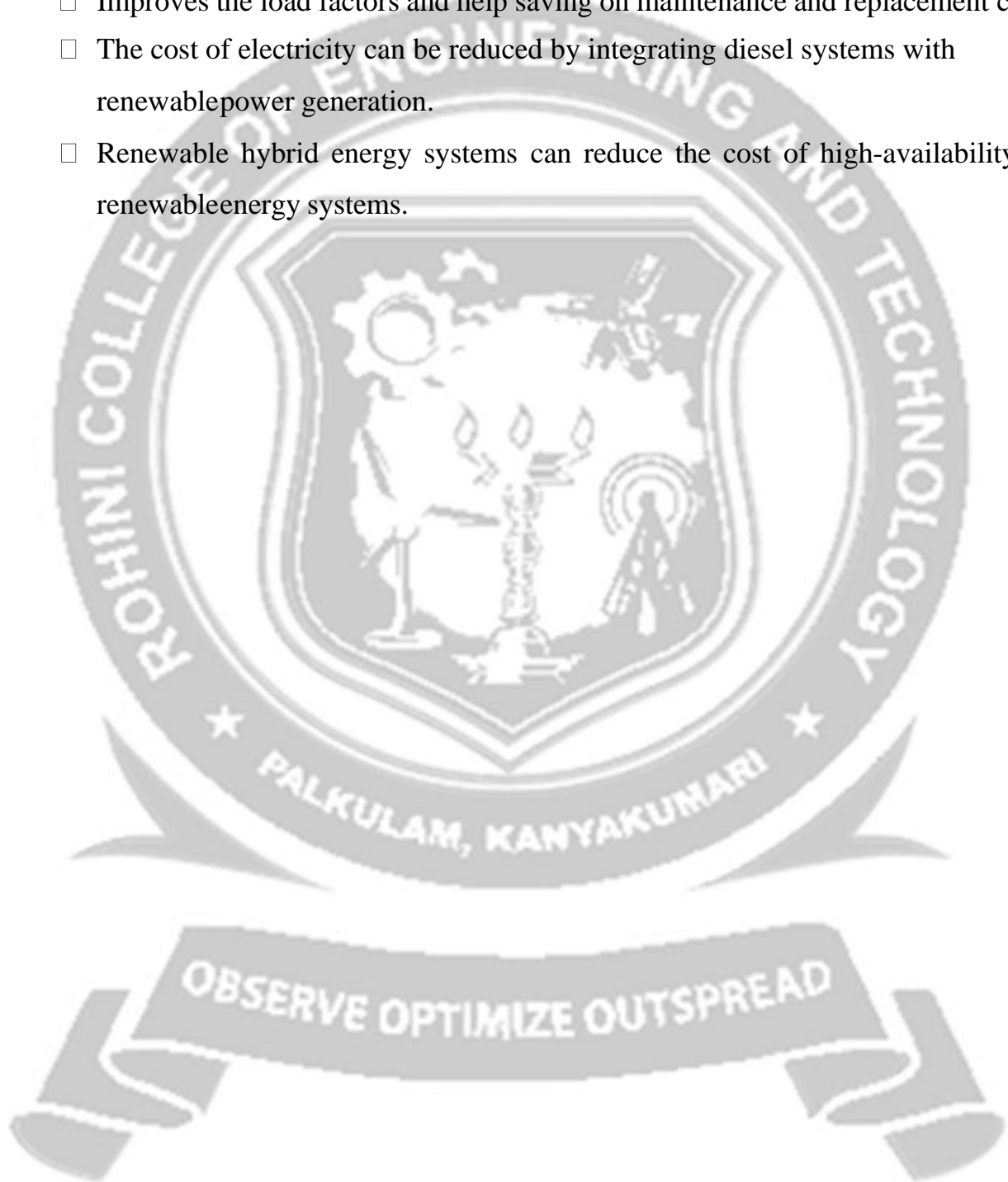

EE3014 POWER ELECTRONICS FOR RENEWABLE ENERGY SYSTEMS**UNIT II****ELECTRICAL MACHINES FOR WIND ENERGY
CONVERSION****2.1 REFERENCE THEORY FUNDAMENTALS-PRINCIPLE OF
OPERATION AND ANALYSIS****INTRODUCTION TO ELECTRO-MECHANICAL ENERGY CONVERSION**

Energy exists in many forms, and we use numerous devices on a daily basis that convert one form of energy into another. When we speak of electromechanical energy conversion, however, we mean either the conversion of electric energy into mechanical energy or vice versa. For example, an electric motor converts electric energy into mechanical energy. On the other hand, an electric generator transforms mechanical energy to electric energy. Electromechanical energy conversion is a reversible process except for the losses in the system. The term "reversible" implies that the energy can be transferred back and forth between the electrical and the mechanical systems. However, each time we go through an energy conversion process, some of the energy is converted into heat and is lost from the system forever.

When a current-carrying conductor is placed in a magnetic field, it experiences a force that tends to move it. If the conductor is free to move in the direction of the magnetic force, the magnetic field aids in the conversion of electric energy into mechanical energy. This is essentially the principle of operation of all electric motors. On the other hand, if an externally applied force makes the conductor move in a direction opposite to the magnetic force, the mechanical energy is converted into electric energy. Generator action is based upon this principle.

Introduction For energy conversion between electrical and mechanical forms, electromechanical devices are developed. In general, electromechanical energy conversion devices can be divided into three categories:

Transducers (for measurement and control): These devices transform the signals of different forms. Examples are microphones, pickups, and speakers.

Force producing devices (linear motion devices): These type of devices produce forces mostly for linear motion drives, such as relays, solenoids (linear actuators), and electromagnets.

Continuous energy conversion equipment: These devices operate in rotating mode. A device would be known as a generator if it converts mechanical energy into electrical energy, or as a motor if it does the other way around (from electrical to mechanical). Since the permeability of ferromagnetic materials is much larger than the permittivity of dielectric materials, it is more advantageous to use electromagnetic field as the medium for electromechanical energy conversion.

REFERENCE THEORY FUNDAMENTALS

Transformation of three phase electrical quantities to two phase quantities is a usual practice to simplify analysis of three phase electrical circuits. Polyphase A.C machines can be represented by an equivalent two phase model provided the rotating polyphases winding in rotor and the stationary polyphase windings in stator can be expressed in a fictitious two axes coils. The process of replacing one set of variables to another related set of variable is called winding transformation or simply transformation or linear transformation. The term linear transformation means that the transformation from old to new set of variable and vice versa is governed by linear equations. The equations relating old variables and new variables are called transformation equation and the following general form:

$$[\text{New Variable}] = [\text{Transformation matrix}] [\text{Old variable}]$$

$$[\text{Old Variable}] = [\text{Transformation matrix}]^{-1} [\text{New variable}]$$

Transformation matrix is a matrix containing the coefficients that relates new and old variables. Note that the second transformation matrix in the above-mentioned general form is inverse of first transformation matrix. The transformation matrix should account for power invariance in the two frames of reference. In case power invariance is not maintained, then torque calculation should be from original machine variables

only.

INTRODUCTION TO REFERENCE FRAME THEORY

Overview

As the application of ac machines has continued to increase over this century, new techniques have been developed to aid in their analysis. Much of the analysis has been carried out for the treatment of the well-known induction machine. The significant breakthrough in the analysis of three-phase ac machines was the development of reference frame theory. Using these techniques, it is possible to transform the phase variable machine description to another reference frame. By judicious choice of the reference frame, it proves possible to simplify considerably the complexity of the mathematical machine model. While these techniques were initially developed for the analysis and simulation of ac machines, they are now invaluable tools in the digital control of such machines. As digital control techniques are extended to the control of the currents, torque and flux of such machines, the need for compact, accurate machine models is obvious.

Fortunately, the developed theory of reference frames is equally applicable to the synchronous machines, such as the Permanent Magnet Synchronous Machine (PMSM). This machine is sometimes known as the sinusoidal brushless machines or the brushless ac machine and is very popular as a high-performance servo drive due to its superior torque-to-weight ratio and its high dynamic capability. It is a three-phase synchronous ac machine with permanent-magnet rotor excitation and is designed to have a sinusoidal torque-position characteristic. The aim of this section is to introduce the essential concepts of reference frame theory and to introduce the space vector notation that is used to write compact mathematical descriptions of ac machines. Over the years, many different reference frames have been proposed for the analysis of ac machines. The most commonly used ones are the so-called stationary reference frame and the rotor reference frame.

Clarke's Transformation

The transformation of stationary circuits to a stationary reference frame was developed by E. Clarke. The stationary two-phase variables of Clarke's transformation are denoted as α and β . As shown in Figure 2.1, α -axis and β -axis are orthogonal.

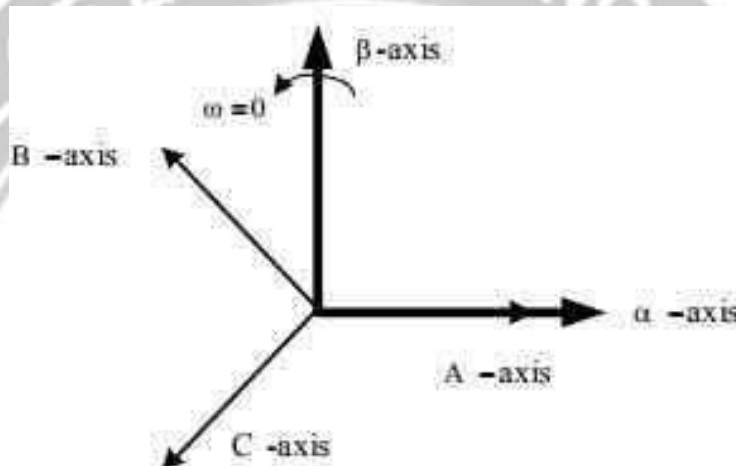

Figure 2.1: Clarke's transformation

In order for the transformation to be invertible, a third variable, known as the zero-sequence component, is added. The resulting transformation is

$$[f_{\alpha\beta 0}] = T_{\alpha\beta 0} [f_{abc}] \quad (1)$$

where

$$[f_{\alpha\beta 0}] = [f_{\alpha} \quad f_{\beta} \quad f_0]^T$$

and

$$[f_{abc}] = [f_a \quad f_b \quad f_c]^T$$

Where f represents voltage, current, flux linkages, or electric charge and the

transformation matrix, $T_{\alpha\beta 0}$, is given by

$$T_{\alpha\beta 0} = \frac{2}{3} \begin{bmatrix} 1 & -\frac{1}{2} & -\frac{1}{2} \\ 0 & \frac{\sqrt{3}}{2} & -\frac{\sqrt{3}}{2} \\ \frac{1}{2} & \frac{1}{2} & \frac{1}{2} \end{bmatrix} \quad (2)$$

The inverse transformation is given by

$$[f_{abc}] = T_{\alpha\beta 0}^{-1}[f_{\alpha\beta 0}] \quad (3)$$

where the inverse transformation matrix is presented by

$$T_{\alpha\beta 0}^{-1} = \frac{2}{3} \begin{bmatrix} 1 & 0 & 1 \\ -\frac{1}{2} & \frac{\sqrt{3}}{2} & 1 \\ \frac{1}{2} & -\frac{\sqrt{3}}{2} & 1 \end{bmatrix} \quad (4)$$

Park's Transformation

Park's transformation, a revolution in machine analysis, has the unique property of eliminating all time varying inductances from the voltage equations of three-phase ac machines due to the rotor spinning. Although changes of variables are used in the analysis of ac machines to eliminate time-varying inductances, changes of variables are also employed in the analysis of various static and constant parameters in power system components. Fortunately, all known real transformations for these components are also contained in the transformation to the arbitrary reference frame. The same general transformation used for the stator variables of ac machines serves the rotor variables of induction machines. Park's transformation is a well-known three- phase to two-phase transformation in synchronous machine analysis.

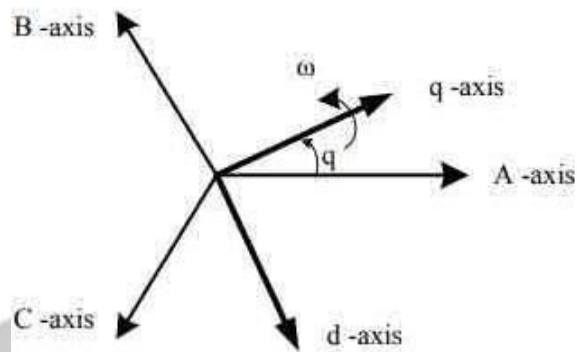

Park's transformation

The transformation equation is of the form

$$[f_{dq0s}] = T_{dq0}(\theta)[f_{abc s}] \quad (1)$$

where

$$[f_{dq0s}] = [f_{qs} \quad f_{ds} \quad f_{0s}]^T$$

and

$$[f_{abc s}] = [f_{as} \quad f_{bs} \quad f_{cs}]^T$$

and the dq0 transformation matrix is defined as

$$T_{dq0}(\theta) = \frac{2}{3} \begin{bmatrix} \cos(\theta) & \cos(\theta - \frac{2\pi}{3}) & \cos(\theta + \frac{2\pi}{3}) \\ \sin(\theta) & \sin(\theta - \frac{2\pi}{3}) & \sin(\theta + \frac{2\pi}{3}) \\ \frac{1}{2} & \frac{1}{2} & \frac{1}{2} \end{bmatrix} \quad (2)$$

θ is the angular displacement of Park's reference frame and can be calculated by

$$\theta = \int_0^t \omega(\zeta) d\zeta + \theta(0) \quad (3)$$

where ζ is the dummy variable of integration. It can be shown that for the inverse transformation we can write

$$[f_{abc s}] = T_{dq0}(\theta)^{-1} \cdot [f_{dq0s}] \quad (4)$$

$$T_{dq0}^{-1}(\theta) = \begin{bmatrix} \cos \theta & \sin \theta & 1 \\ \cos \left(\theta - \frac{2\pi}{3} \right) & \sin \left(\theta - \frac{2\pi}{3} \right) & 1 \\ \cos \left(\theta + \frac{2\pi}{3} \right) & \sin \left(\theta + \frac{2\pi}{3} \right) & 1 \end{bmatrix} \quad (5)$$

where the inverse of Park's transformation matrix is given by



In the previous equations, the angular displacement θ must be continuous, but the angular velocity associated with the change of variables is unspecified. The frame of reference may rotate at any constant, varying angular velocity, or it may remain stationary. The angular velocity of the transformation can be chosen arbitrarily to best fit the system equation solution or to satisfy the system constraints. The change of variables may be applied to variables of any waveform and time sequence; however, we will find that the transformation given above is particularly appropriate for an a-b-c sequence.

Transformations between Reference Frames

In order to reduce the complexity of some derivations, it is necessary to transform the variables from one reference frame to another one. To establish this transformation between any two reference frames, we can denote y as the new reference frame and x as the old reference frame. Both new and old reference frames are shown in Figure.

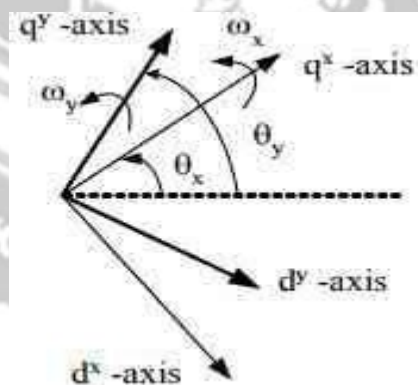

Transformation between two reference frames

It is assumed that the reference frame x is rotating with angular velocity ω_x and the reference frame y is spinning with the angular velocity ω_y . θ_x and θ_y are angular displacements of reference frames x and y , respectively. In this regard, we can rewrite the transformation equation as

$$[f_{dq0s}^y] = T_{dq0s}^{x \rightarrow y} \cdot [f_{dq0s}^x] \quad (1)$$

But we have

$$[f_{dq0s}^x] = T_{dq0s}^x \cdot [f_{abcs}] \quad (2)$$

If we substitute (2) in (1) we get

$$[f_{dq0s}^y] = T_{dq0s}^{x \rightarrow y} \cdot T_{dq0s}^x \cdot [f_{abcs}] \quad (3)$$



In another way, we can find out that

$$[f_{dq0s}^y] = T_{dq0s}^y \cdot [f_{abcs}] \quad (4)$$

From (3) we obtain

$$T_{dq0s}^{x \rightarrow y} = T_{dq0s}^y \cdot T_{dq0s}^x^{-1} \quad (5)$$

Then, the desired transformation can be expressed by the following matrix:

$$T_{dq0s}^{x \rightarrow y} = \begin{bmatrix} \cos(\theta_y - \theta_x) & -\sin(\theta_y - \theta_x) & 0 \\ \sin(\theta_y - \theta_x) & \cos(\theta_y - \theta_x) & 0 \\ 1 & 1 & 1 \end{bmatrix} \quad (6)$$

Field Oriented Control (FOC) Transformations

Machine side transformation in field oriented control

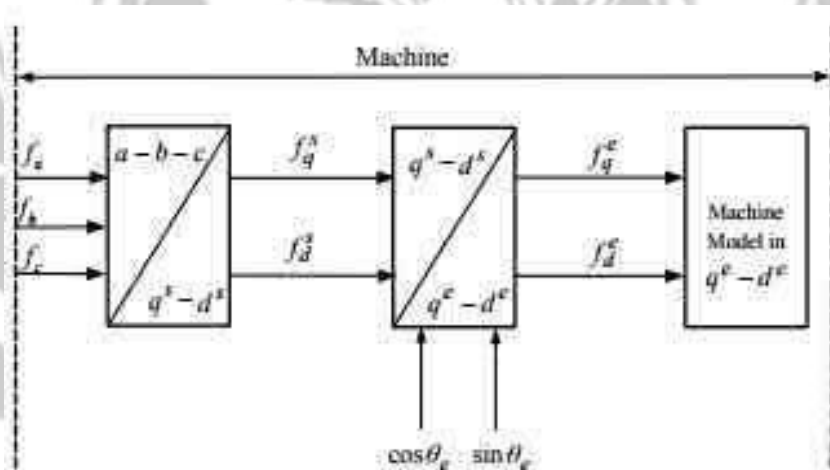

Machine side transformation in field oriented control

In the case of FOC of electric machines, control methods are performed in a two-phase reference frame fixed to the rotor (q^r-d^r) or fixed to the excitation reference frame (q^e-d^e). We want to transform all the variables from the three-phase a-b-c system to the two-phase stationary reference frame and then retransform these variables from the stationary reference frame to a rotary reference frame with arbitrary angular velocity of ω . These transformations are usually cascaded. The block diagram of this procedure is shown in Figure

Variable transformation in the field oriented control.

In this figure, f denotes the currents or voltages and q^e - d^e represents the arbitrary rotating reference frame with angular velocity θ_e and q^s - d^s represents the stationary reference frame. In the vector control method, after applying field oriented control it is necessary to



transform variables to stationary a-b-c system. This can be achieved by taking the inverse transformation of variables from the arbitrary rotating reference frame to the stationary reference frame and then to the a-b-c system. In this block diagram, * is a representation of commanded or desired values of variables.

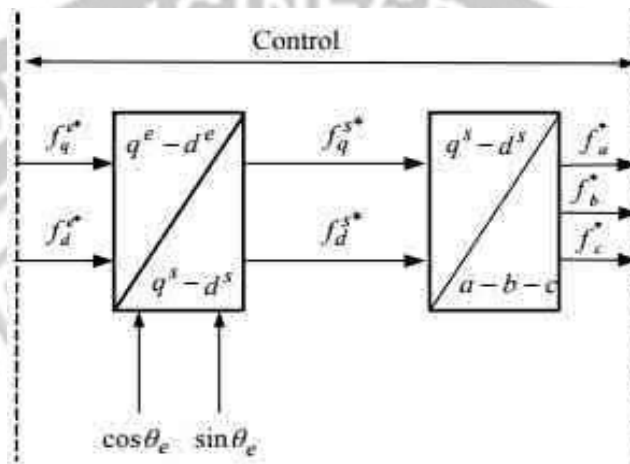

Variable transformation in the field oriented control

Commonly used reference frames

Based on speed of reference frame there are four major type of reference frames

- 1. Arbitrary reference frame:** Reference frame speed is unspecified (ω), variables denoted by f_{dqos} or f_{ds} , f_{qs} and f_{os} , transformation matrix denoted by K_s .
- 2. Stationary reference frame:** Reference frame speed is zero ($\omega=0$), variables denoted by f_{dqo}^s or f_{dq}^s , f_{qs}^s and f_{os}^s , transformation matrix denoted by K_s^s .
- 3. Rotor reference frame:** Reference frame speed is equal to rotor speed ($\omega= \omega_r$), variables denoted by f_{dqo}^r or f_{dq}^r , f_{qs}^r and f_{os}^r , transformation matrix denoted by K_s^r .
- 4. Synchronous reference frame:** Reference frame speed is equal to synchronous speed ($\omega= \omega_e$), variables denoted by f_{dqo}^e or f_{dq}^e , f_{qs}^e and f_{os}^e , transformation matrix denoted by K_s^e .

The choice of reference frame is not restricted but otherwise deeply influenced by the type of analysis that is to be performed so as to expedite the solution of the system equations or to satisfy system constraints. The best suited choice of reference frame for simulation of induction machine for various cases of analysis is listed here under:



- **Stationary reference frame** is best suited for studying stator variables only, for example variable speed stator fed IM drives, because stator d-axis variables are exactly identical to stator phase a-variable.
- **Rotor reference frame** is best suited when analysis is restricted to rotor variables as rotor d-axis variable is identical to phase-a rotor variable.
- **Synchronously rotating reference frame** is suitable when analog computer is employed because both stator and rotor d-q quantities becomes steady DC quantities. It is also best suited for studying multi-machine system.

It is worthwhile to note that all three types of reference frame can be obtained from arbitrary reference frame by simply changing ω . Modeling in arbitrary reference frame is therefore beneficial when a wide range of analysis is to be done.

Induction Machine Model in the Park Reference Frame

The induction machine was modeled using two separate frames. The first one is used to express stator quantities; the second one is used to express rotor quantities. Since these two frames are linked with angle θ , a model of the machine in a common frame named d, q can be obtained using the two rotation matrices. At a certain point, the position of the magnetic field

rotating in the air gap is pinpointed by angle θ_s ; in relation to stationary axis s_a : For the development of the machine model, a Park reference frame is assumed to be lined up with this

magnetic field and to rotate at the same speed (ω_s): Angle θ_s corresponds to the angle of axes s_x

and θ_r ; angle θ_r corresponds to the angle of axes r_x and d : Transforming angle θ_s is necessary to bring the stator quantities back to the Park rotating reference frame. Transforming angle θ_r is necessary to bring the rotor quantities back. The figure indicates that the angles are linked by a

relation in order to express the rotor and stator quantities in the same Park reference

frame (;

$\vec{\omega}_d; \vec{\omega}_q$). This relation is:

$$\theta_s = \theta + \theta_r \quad (1)$$

The same situation happens between the frame speeds in each frame and the mechanical speed, that is:

$$\omega_s = \omega + \omega_r \quad (2)$$

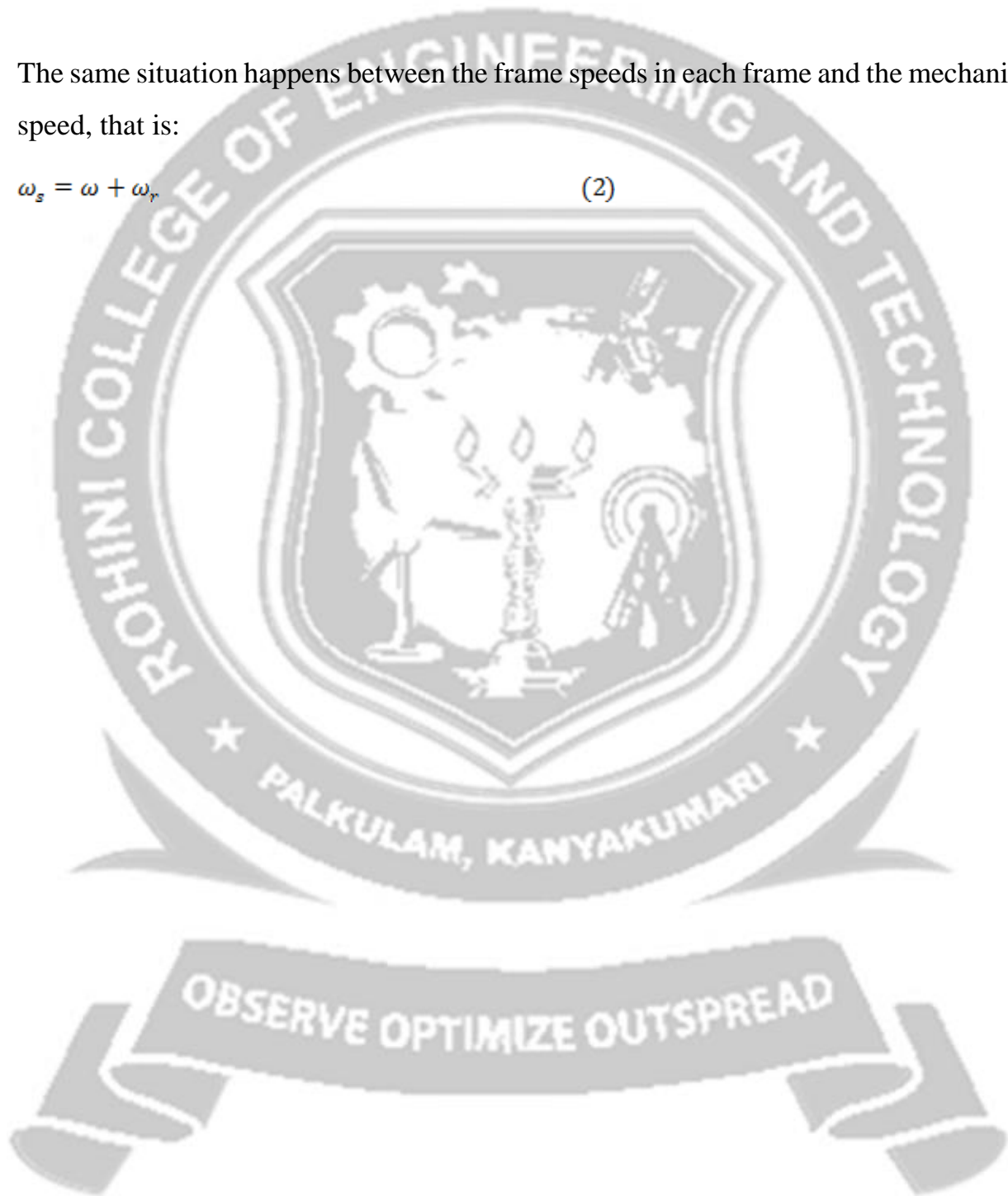

$$\omega_s = \frac{d\theta_s}{dt}, \omega_r = \frac{d\theta_r}{dt}, \omega = p\Omega = \frac{d\theta}{dt} \quad (3)$$

where Ω is mechanical speed and ω is very speed viewed in the electrical space.

The speed of the rotor quantities is ω_r in relation to rotor speed ω . In relation to the stator frame, the rotor quantities consequently rotate at the same speed ω_s as the stator quantities. Using the Park transform will allow the conception of an induction machine model independent

from the rotor position. Two transformations are used. One $[P(\theta_s)]$ is applied to the stator quantities; the other $[P(\theta_r)]$ is applied to the rotor quantities.

$$[X_{s,dqo}] = [P(\theta_s)][X_{s,abc}][X_{r,dqo}] = [P(\theta_r)][X_{r,abc}] \quad (4)$$

Direct and squared components x_d, x_q represent coordinates x_a, x_b, x_c in an orthogonal frame of reference rotating in the same plane. Term x_o represents the homopolar component, which is orthogonal to the plane constituted by the system x_a, x_b, x_c .



EE3014 POWER ELECTRONICS FOR RENEWABLE ENERGY SYSTEMS**UNIT II****ELECTRICAL MACHINES FOR WIND ENERGY****CONVERSION****2.2 - IG****INDUCTION GENERATORS (IG)****Introduction**

An induction generator or asynchronous generator is a type of alternating current (AC) electrical generator that uses the principles of induction motors to produce power. Induction generators operate by mechanically turning their rotors faster than synchronous speed. A regular AC asynchronous motor usually can be used as a generator, without any internal modifications. Induction generators are useful in applications such as mini hydro power plants, wind turbines, or in reducing high-pressure gas streams to lower pressure, because they can recover energy with relatively simple controls. An induction generator usually draws its excitation power from an electrical grid; sometimes, however, they are self-excited by using phase-correcting capacitors. Because of this, induction generators cannot usually "black start" a de-energized distribution system. Induction Generator construction is based on the very common squirrel-cage induction motor type machine as they are cheap, reliable, and readily available in a wide range of electrical sizes from fractional horse power machines to multi-megawatt capacities making them ideal for use in both domestic and commercial renewable energy wind power applications.

Induction generator is not a self excited machine therefore in order to develop the rotating magnetic field, it requires magnetizing current and reactive power. The induction generator obtains its magnetizing current and reactive power from the various sources like the

supply mains or it may be another synchronous generator. The induction generator can't work in isolation because it continuously requires reactive power from the supply system. However we can have a self excited or isolated induction generation in one case if we will use capacitor bank for reactive power supply instead of AC supply system.

Construction

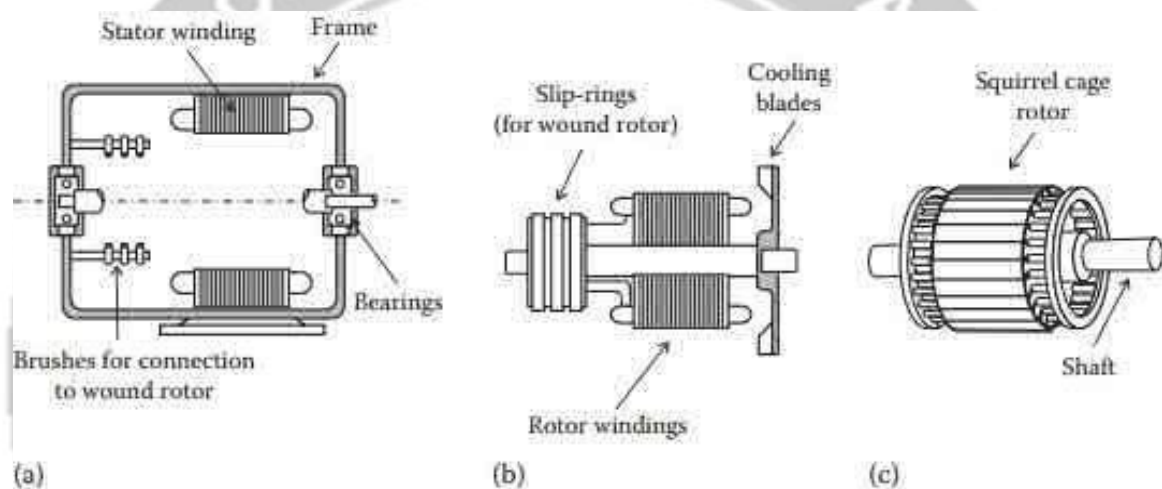

Induction machine longitudinal cut: (a) stator, (b) wound rotor, and (c) cage rotor

An induction generator is made up of two major components: the stator, which consists of steel laminations mounted on a frame so that slots are formed on the inside diameter of the assembly as in a synchronous machine, and the rotor, which consists of a structure of steel laminations mounted on a shaft with two possible configurations:

Wound rotor or cage rotor. Figure shows a schematic cut along the longitudinal axis of a typical wound-rotor induction machine. Figure (a) shows the external case with the stator yoke internally providing the magnetic path for the three-phase stator circuits. Bearings provide mechanical support for the shaft clearance (the air gap) between the rotor and stator cores. For a wound rotor, a group of brush holders and carbon brushes, indicated on the left side of Figure (a), allow for connection to the rotor windings. A schematic diagram of a wound rotor is shown in Figure (b). The winding of the wound rotor is of the three-phase type with the same number of poles as the stator, generally

connected in Y.



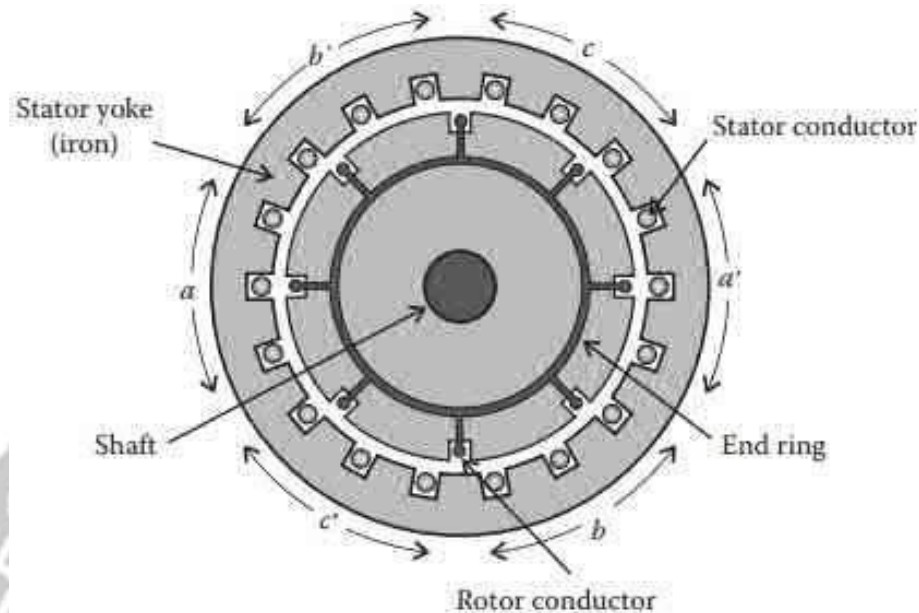

Cross-sectional cut for an induction machine

Three terminal leads are connected to the slip rings by means of carbon brushes. Wound rotors are usually available for very large power machines (>500 kW). External converters in the rotor circuit, rated with slip power, control the secondary currents providing the rated frequency at the stator. For most medium power applications, squirrel cage rotors, as in Figure (c), are used. Squirrel cage rotor windings consist of solid bars of conducting material embedded in the rotor slots and shorted at the two ends by conducting rings. In large machines, the rotor bars may be of copper alloy brazed to the end rings. Rotors sized up to about 20 inches in diameter are usually stacked in a mold made by aluminum casting, enabling a very economical structure combining the rotor bars, end rings, and cooling fan. Figure shows a cross-sectional cut indicating the distributed windings for three-phase stator excitation. Each winding (a, b, or c) occupies the contiguous slots within a 120° spatial distribution.

The stator: It is built up from silicon steel laminations punched and assembled so that it has a number of uniformly spaced identical slots, in integral multiples of six (such as 48 or 72 slots), roughly parallel to the machine shaft. Sometimes, the slots are slightly twisted or skewed in relation to the longitudinal axis, to reduce cogging torque, noise, and vibration, and to smooth up the generated voltage. Machines up to a few hundreds of KW rating and low voltage have semi closed slots, while larger machines

with medium voltage have open slots.

Off-grid Induction Generator

We have seen above that an induction generator requires the stator to be magnetized from the utility grid before it can generate electricity. But you can also run an induction generator in a stand alone, off-grid system by supplying the necessary out-of-phase exciting or



magnetizing current from excitation capacitors connected across the stator terminals of the machine. This also requires that there is some residual magnetism in the rotors iron laminations when you start the turbine. The excitation capacitors are shown in a star (wye) connection but can also be connected a delta (triangular) arrangement.

Capacitor Start Induction Generator

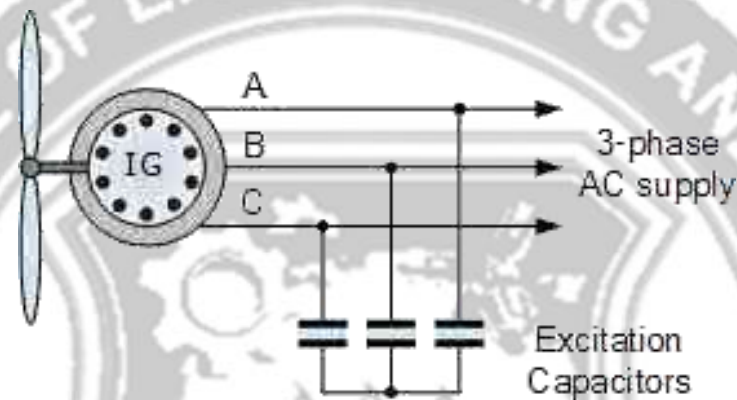

Capacitor Start Induction Generator

The excitation capacitors are standard motor-starting capacitors that are used to provide the required reactive power for excitation which would otherwise be supplied by the utility grid. The induction generator will self-excite using these external capacitors only if the rotor has sufficient residual magnetism. In the self-excited mode, the generator output frequency and voltage are affected by the rotational speed, the turbine load, and the capacitance value in farads of the capacitors. Then in order for self-excitation of the generator to occur, there needs to be a minimum rotational speed for the value of capacitance used across the stator windings. The Self-excited induction generator (SEIG) is a good candidate for wind powered electric generation applications especially in variable wind speed and remote areas, because they do not need external power supply to produce the magnetic field. A three-phase induction generator can be converted into a variable speed single-phase induction generator by connecting two excitation capacitors across the three-phase windings. One of value C amount of capacitance on one phase and the other of value $2C$ amount of capacitance across the other phase.

Principle of operation



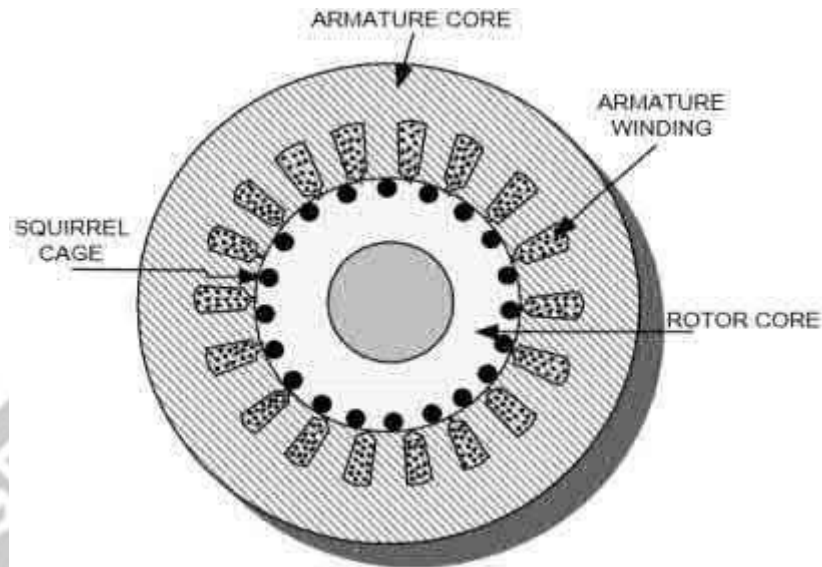

An induction generator produces electrical power when its rotor is turned faster than the synchronous speed. For a typical four-pole motor (two pairs of poles on stator) operating on a 60 Hz electrical grid, the synchronous speed is 1800 rotations per minute (rpm). The same four-pole motor operating on a 50 Hz grid will have a synchronous speed of 1500 RPM. The motor normally turns slightly slower than the synchronous speed; the difference between synchronous and operating speed is called "slip" and is usually expressed as per cent of the synchronous speed. For example, a motor operating at 1450 RPM that has a synchronous speed of 1500 RPM is running at a slip of +3.3%. In normal motor operation, the stator flux rotation is faster than the rotor rotation. This causes the stator flux to induce rotor currents, which create a rotor flux with magnetic polarity opposite to stator. In this way, the rotor is dragged along behind stator flux, with the currents in the rotor induced at the slip frequency. In generator operation, a [prime mover](#) (turbine or engine) drives the rotor above the synchronous speed (negative slip). The stator flux still induces currents in the rotor, but since the opposing rotor flux is now cutting the stator coils, an active current is produced in stator coils and the motor now operates as a generator, sending power back to the electrical grid.

Excitation

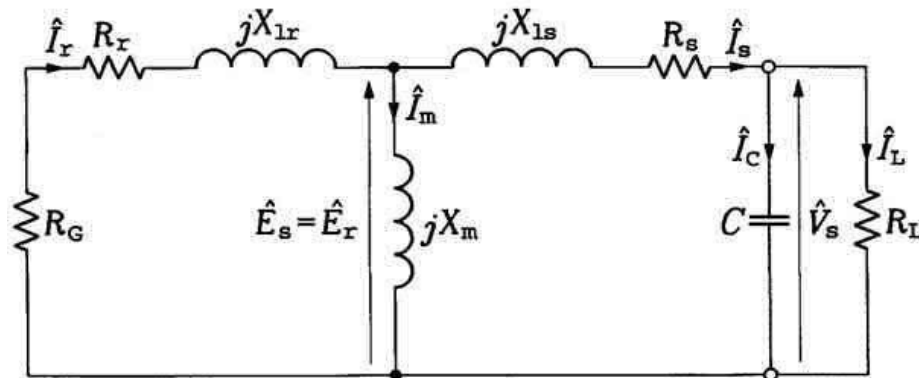

Per-phase equivalent circuit of the stand-alone induction generator

An induction machine requires externally supplied armature current. Because the rotor field always lags behind the stator field, the induction machine always "consumes" reactive power, regardless of whether it is operating as a generator or a motor. A source of excitation current for magnetizing flux (reactive power) for the stator is still required, to induce rotor current. This can be supplied from the electrical grid or, once it starts producing power, from the generator itself. An induction machine can be started by charging the capacitors, with a DC source, while the generator is turning typically at or above generating speeds. Once the DC source is removed the capacitors will provide the magnetization current required beginning producing voltage. An induction machine that has recently been operating may also spontaneously produce voltage and current due to residual magnetism left in the core.

Active power

Active power delivered to the line is proportional to slip above the synchronous speed. Full rated power of the generator is reached at very small slip values (motor dependent, typically 3%). At synchronous speed of 1800 rpm, generator will produce no power. When the driving speed is increased to 1860 rpm (typical example), full output power is produced. If the prime mover is unable to produce enough power to fully drive the generator, speed will remain somewhere between 1800 and 1860 rpm range.

Required capacitance

A capacitor bank must supply reactive power to the motor when used in stand-alone mode. The reactive power supplied should be equal or greater than the reactive power that the machine normally draws when operating as a motor. Consider, an AC supply is connected to the stator terminals of an induction machine. Rotating magnetic field produced in the stator pulls the rotor to run behind it (the machine is acting as a motor). Now, if the rotor is accelerated to the synchronous speed by means of a prime mover, the slip will be zero and hence the net torque will be zero. The rotor current will become zero when the rotor is running at synchronous speed.

If the rotor is made to rotate at a speed more than the synchronous speed, the slip becomes negative. A rotor current is generated in the opposite direction, due to the rotor conductors cutting stator magnetic field. This generated rotor current produces a rotating magnetic field in the rotor which pushes (forces in opposite way) onto the stator field. This causes a stator voltage which pushes current flowing out of the stator winding against the applied voltage. Thus, the machine is now working as an induction generator (asynchronous generator).

Torque-Slip characteristics

The basic fundamental of induction generators is the conversion between mechanical energy to electrical energy. This requires an external torque applied to the rotor to turn it faster than the synchronous speed. However, indefinitely increasing torque doesn't lead to an indefinite increase in power generation. The rotating magnetic

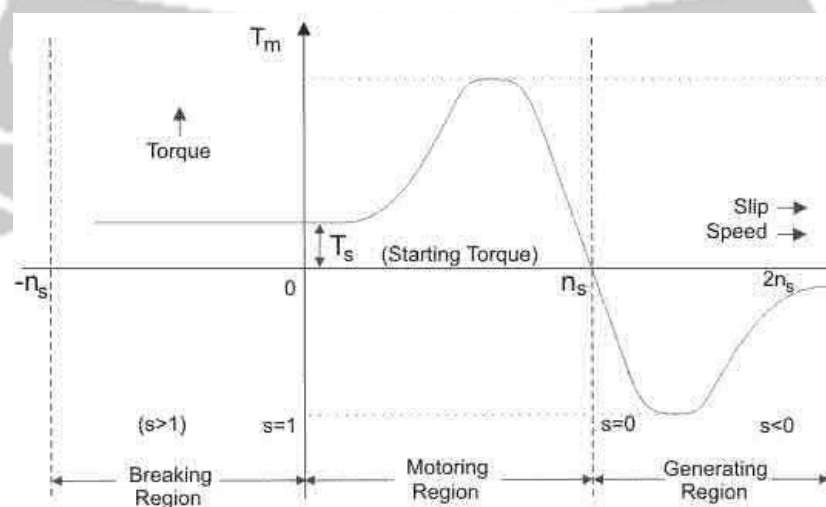

ROHINI COLLEGE OF ENGINEERING

field torque excited from the armature works to counter the motion of the rotor and prevent over speed because of induced motion in the opposite direction.

As the speed of the motor increases the counter torque reaches a max value of torque (breakdown torque) that it can operate until before the operating conditions become unstable. Ideally, induction generators work best in the stable region between the no-load condition and maximum torque region.



Torque–Speed characteristics

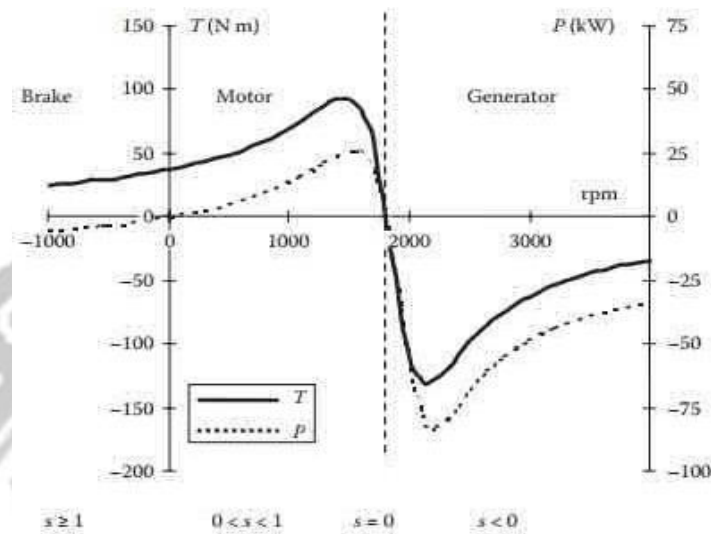

It can be observed that there is no torque at the synchronous speed. Both the torque– speed and the power–speed curves are almost linear since from no load to full load the machine’s rotor resistance is much larger than its reactance. The resistance is predominant in this range, current and the rotor field as well as the induced torque increase almost linearly with the increase of the slip factors. The rotor torque varies as the square of the voltage across the terminals of the generator if the speed slows down close to the synchronous speed, the generator motorizes that is, it works as a motor; as we will show, the generated power has a maximum value for a given current drained from the generator in the same way, there is a maximum possible induced generator torque called pullout or breakdown torque, and from this torque value on, there will be over speed. The peak power supplied by the IG happens at a speed slightly different from the maximum torque, and, naturally, no electric power is converted into mechanical power when the rotor is at rest (zero speed). In the same way, in spite of the same rotation, the frequency of the IG varies with the load variation.

HIGH-EFFICIENCY INDUCTION GENERATOR

A high-efficiency induction generator is commercially available as a high-efficiency induction motor, except for some peculiarities. Therefore, the same care must be taken in design, materials selection, and manufacturing processes for building a high-

efficiency generator. The main advantages of the high-efficiency induction generator compared with the conventional induction generator are better voltage regulation, less loss of efficiency. Steady-state model of Induction Generators with smaller loads, less over sizing when generators of lower power cannot be used, reduced internal losses, and, therefore, lower temperatures, less internal electric and mechanical stress, and, thus, increased useful life.

The constraints are the need for larger capacitors for self-excitation. High-efficiency induction generators should not be used for self-excited applications. The efficiency of the high- efficiency generator compared with the standard ones differs by more than about 10% for small power ratings (up to 50 kW) and about 2% for higher powers (above 100 kW). It is therefore highly recommended for micro power plants. Rated efficiencies are normalized, and they should have guaranteed minimum values stated by the manufacturer on the plate of the machine for each combination of power versus synchronous speed. High-efficiency generators are better suited to stand the harmful effects of the harmonic generated by nonlinear loads (power converters) because they have higher thermal margin and smaller losses.

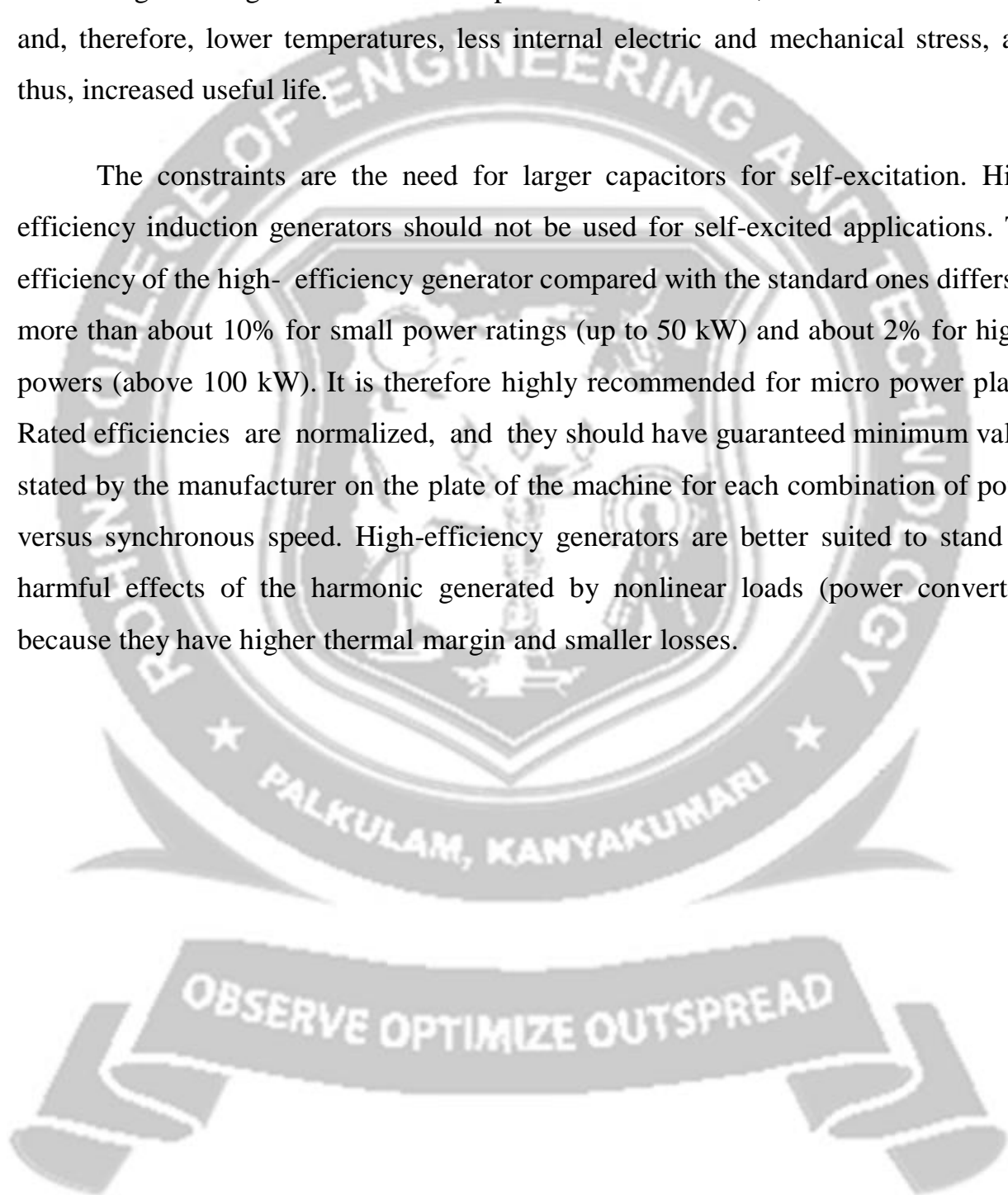

EE3014 POWER ELECTRONICS FOR RENEWABLE ENERGY SYSTEMS**UNIT II****ELECTRICAL MACHINES FOR WIND ENERGY****CONVERSION****2.3-PMSG****PERMANENT MAGNET SYNCHRONOUS GENERATORS (PMSG)****Introduction**

A permanent magnet synchronous generator is a generator where the excitation field is provided by a permanent magnet instead of a coil. The term synchronous refers here to the fact that the rotor and magnetic field rotate with the same speed, because the magnetic field is generated through a shaft mounted permanent magnet mechanism and current is induced into the stationary armature. Synchronous generators are the majority source of commercial electrical energy. They are commonly used to convert the mechanical power output of steam turbines, gas turbines, reciprocating engines and hydro turbines into electrical power for the grid. Some designs of Wind turbines also use this generator type.

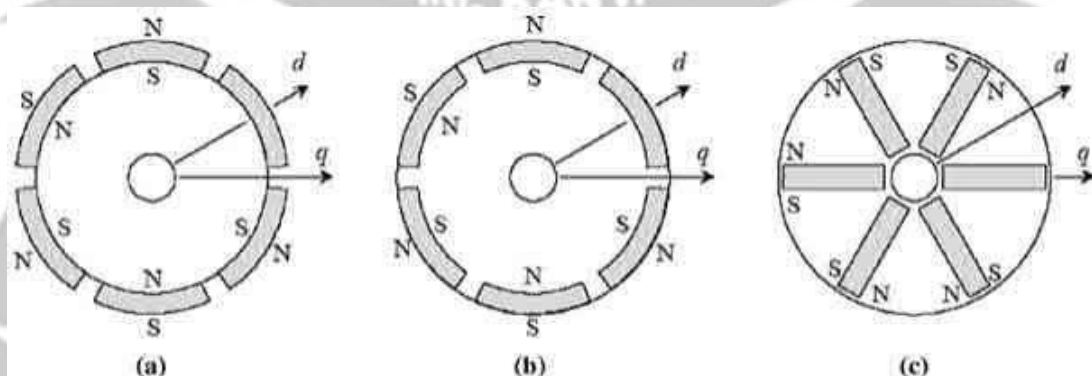
Construction**Types of PMSG rotor construction**

(a) Surface mounted; (b) inset; (c) Interior PM motor

A Permanent Magnet Synchronous Generator is a generator where the excitation

field is provided by a permanent magnet instead of a coil. The rotor contains the permanent magnet and the stator is the stationary armature that is electrically connected to a load. A set of 3 conductors make up the armature winding in standard utility equipment, placed 120° apart in space, this provides for a uniform force or torque on the generator rotor. The uniformity of the torque arises



because the magnetic field resulting from the currents in the three conductors of the armature winding combine spatially in such a way as to resemble the magnetic field of a single rotating magnet. The stator magnetic field appears as a steady rotating field and spins at the same frequency as the rotor when the rotor contains a single dipole magnetic field. The two fields move in 'synchronicity' and maintain a fixed position with respect to each other as they rotate. The armature MMF combines vectorically with the persistent flux of the permanent magnets, which leads to higher air-gap flux density and eventually core saturation. In PMSG, the output voltage is proportional to the speed.

Operation

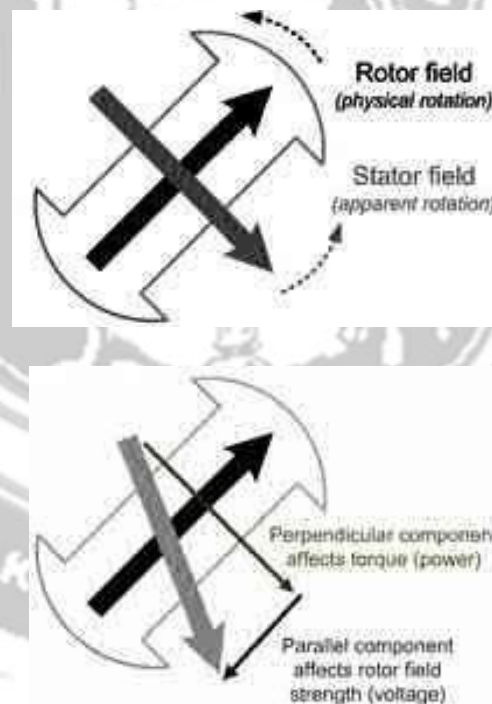

In the majority of designs the rotating assembly in the center of the generator called "rotor" contains the magnet, and the "stator" is the stationary armature that is electrically connected to a load. As shown in the diagram, the perpendicular component of the stator field affects the torque while the parallel component affects the voltage. The load supplied by the generator determines the voltage. If the load is inductive, then the angle between the rotor and stator fields will be greater than 90 degrees which corresponds to an increased generator voltage. This is known as an overexcited

generator.

The opposite is true for a generator supplying a capacitive load which is known as an under excited generator. A set of three conductors make up the armature winding in standard utility equipment, constituting three phases of a power circuit that correspond to the three wires we are accustomed to see on transmission lines. The phases are wound such that they are 120



degrees apart spatially on the stator, providing for a uniform force or torque on the generator rotor. The uniformity of the torque arises because the magnetic fields resulting from the induced currents in the three conductors of the armature winding combine spatially in such a way as to resemble the magnetic field of a single, rotating magnet. This stator magnetic field or "stator field" appears as a steady rotating field and spins at the same frequency as the rotor when the rotor contains a single dipole magnetic field. The two fields move in "synchronicity" and maintain a fixed position relative to each other as they spin.

Advantages and disadvantages of PMSG

Advantages

- ❖ Light weight and small size in construction.
- ❖ Low losses and high efficiency
- ❖ No need of external excitation current.
- ❖ No need of gearbox.

Disadvantages

- ❖ It is useful for small wind turbines, but for large wind turbines the size of the magnets has to be increased.
- ❖ Demagnetization of permanent magnet due to atmospheric conditions is a big problem

EE3014 POWER ELECTRONICS FOR RENEWABLE ENERGY SYSTEMS**UNIT II****ELECTRICAL MACHINES FOR WIND ENERGY
CONVERSION****2.4- SCIG****SQUIRREL CAGE INDUCTION GENERATORS (SCIG)****Constructional features**

Asynchronous Induction generators are widely used in wind mills due to the several advantages, such as robustness, mechanical simplicity and low price. Induction machines operate in the generating and motoring modes fundamentally in the same manner except for the reversal power flow. Therefore, the equivalent circuit and the associated performance are valid for different slip. If the rotor is driven by a prime mover above the synchronous speed, the mechanical power of the prime mover is converted into electrical power to the utility grid via stator winding. The SCIG is a self-excited induction generator where a three-phase capacitor bank is connected across the stator terminals to supply the reactive power requirement of a load. When such an induction machine is driven by an external mechanical power source, the residual magnetism in the rotor produces an Electromotive Force (EMF) in the stator windings. This

EMF is applied to the capacitor bank causing current flow in the stator winding and establishing a magnetizing flux in the machine.

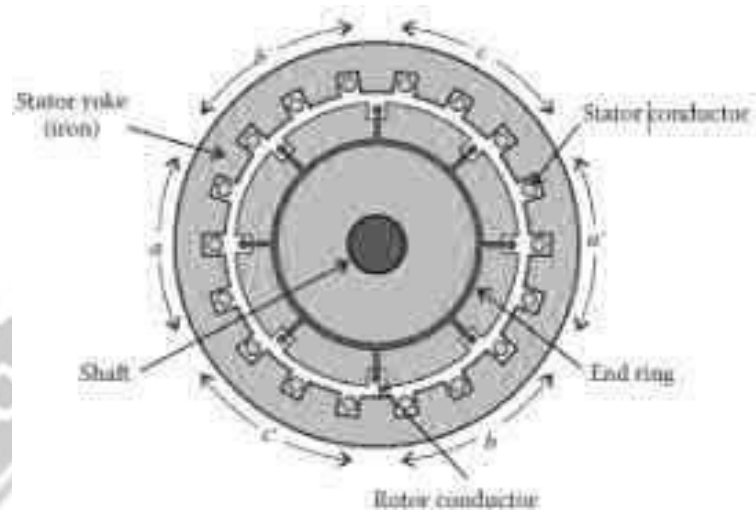

An induction generator connected and excited in this manner is capable of acting as a standalone generator supplying real and reactive power to a load. SCIG have a steep torque speed characteristic and therefore fluctuations in wind power are transmitted directly to the grid. SCIG feed only through the stator and generally operate at low negative slip, approximately 1 to 2

percent. The slip, and hence the rotor speed of a SCIG varies with the amount of power generated. The generator will always draw the reactive power from the grid. Reactive power consumption is partly or fully compensated by capacitors in order to achieve a power factor close to unity and make the induction machine to self-excite. The speed varies over a very small range above synchronous speed as it is coupled with the grid, hence commonly known as a fixed-speed generator. SCIG drives have bulky construction, low efficiency, low reliability and need of maintenance, also the existing of slip ring, brush and three-stage gearbox increases the system mass and cost, also electrical and mechanical loss. Recently, squirrel-cage induction generators are dropping in this application.

Principle of operation

Initially, the induction machine is connected in motoring command such that it generates electromagnetic torque in the same direction as the wind torque. In steady-state, the rotational speed exceeds the synchronous speed and the electromagnetic

torque is negative. This corresponds to the squirrel-cage induction machine operation in generation mode. As it is directly connected to the grid, the SCIG works on its natural mechanical characteristic having an accentuated slope (corresponding to a small slip) given by the rotor resistance. Therefore, the SCIG rotational speed is very close to the synchronous speed imposed by the grid frequency.



Furthermore, the wind velocity variations will induce only small variations in the generator speed.

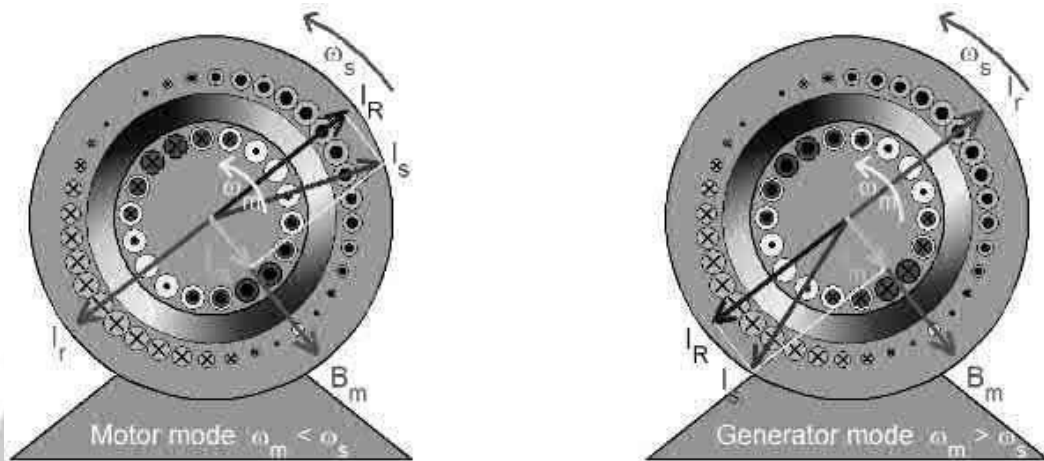

As the power varies proportionally with the wind speed cubed, the associated electromagnetic variations are important. SCIG are preferred because they are mechanically simple, have high efficiency and low maintenance cost. Furthermore, they are very robust and stable. The rotating magnetizing field represented by the space vector \mathbf{B}_m (or, equivalently by the magnetizing current \mathbf{I}_m) moves at the synchronous speed ω_s with respect to a stator (or stationary) observer and at the slip speed $\omega_{sl} = \omega_s - \omega_m$ with respect to a rotor observer. In the motor mode of operation where $\omega_m < \omega_s$, the rotor effectively moves backwards (clockwise) with respect to the field, inducing in each bar a voltage having the polarity indicated and a magnitude proportional to slip velocity u and to the field strength acting on the bar (in accordance with the flux-cutting rule $\mathbf{v} = \mathbf{B}u$). Since the magnetic field is sinusoidally distributed in space, so will the induced voltages in the rotor bars. Ignoring the effects of rotor leakage, the resulting rotor currents are in phase with the induced voltages and are thus sinusoidally distributed in space varying sinusoidally in time at slip frequency; they may then be represented by the space vector \mathbf{I}_r which rotate at the slip speed ω_{sl} with respect to the rotor and at synchronous speed ω_s with respect to the stator. Because \mathbf{B}_m cannot change with a fixed stator input voltage (in accordance with Faraday's law), a stator space vector \mathbf{I}_R is created in order to compensate for the rotor effects so that the resultant stator current becomes $\mathbf{I}_s = \mathbf{I}_R + \mathbf{I}_m$.

The electromagnetic force exerted on rotor bar acting in the positive or anticlockwise direction (same as rotor speed) in the present case of a motor. The resultant torque developed on the rotor also acts in the same direction. Follow the path taken by one rotor bar as it travels around, observing the polarity and magnitude (described by the size) of the bar current. In the case of a generator where $\omega_m > \omega_s$, all polarities and directions are reversed as can be observed in the right figure (except for the magnetizing component).



Modelling of Squirrel Cage Induction Generator (SCIG)

A three-phase voltage system may be expressed, with obvious meaning of the notation, as follows

$$\begin{aligned} V_a(t) &= V \cos(\omega t + \varphi) \\ V_b(t) &= V \cos\left(\omega t + \varphi - \left(\frac{2}{3}\right)\pi\right) \\ V_c(t) &= V \cos\left(\omega t + \varphi - \left(\frac{4}{3}\right)\pi\right) \end{aligned} \quad (1)$$

The corresponding space-vector is calculated in (2). Notice that the amplitude of the defined voltage space-vector is equal to the peak amplitude of the instantaneous voltage:

$$V_s(t) = \frac{2}{3}(v_a(t) + \alpha v_b(t) + \alpha^2 v_c(t)) = v e^{j\varphi} e^{j\omega t} \quad (2)$$

where

$$\alpha = e^{j(2/3)\pi}$$

$$\alpha^2 = e^{-j(2/3)\pi}$$

$$V = V e^{j\varphi}$$

The phasor V is defined in such a way that its magnitude is equal to the peak-value of the voltage. The first part of (2) is valid also if the three-phase quantities do not form a balanced system. In this case, the space vector becomes:

$$V_s(t) = V_1 e^{j\varphi_1} e^{j\omega t} + V_2 v e^{-j\varphi_2} e^{-j\omega t} = V_1 e^{j\omega t} + V_2 e^{-j\omega t} \quad (3)$$

Similar expressions can be obtained for currents and fluxes. The zero-sequence is not considered here, since commonly an induction generator is not grounded and therefore no zero-sequence current can flow. If no zero-sequence component is present, the instantaneous values of the currents in the three phases can be obtained from

the corresponding space-vector as:

$$i_a(t) = \text{Re}(i_s)$$

$$i_b(t) = \text{Re}(a^2 i_s)$$

$$i_c(t) = \text{Re}(a i_s) \quad (4)$$

Using the introduced space-vector notation and using a stationary reference frame, the equations describing the electrical dynamics of a squirrel-cage induction machine are given by :



$$v_s = R_s i_s + \frac{d\psi_s}{dt}$$

$$0 = R_r i_r + \frac{d\psi_r}{dt} - j\psi_r \psi_r \quad (5)$$

$$\psi_s = L_s I_s + L_m I_r$$

$$\psi_r = L_m I_s + L_r I_r \quad (6)$$

where

$$L_s = L_{sl} + L_m \text{ and } L_r = L_{rl} + L_m$$



EE3014 POWER ELECTRONICS FOR RENEWABLE ENERGY SYSTEMS**UNIT II****ELECTRICAL MACHINES FOR WIND ENERGY****CONVERSION****2.5- DFIG****DOUBLY FED INDUCTION GENERATORS (DFIG)****Constructional features**

Doubly fed electrical generators are similar to AC electrical generators, but have additional features which allow them to run at speeds slightly above or below their natural synchronous speed. This is useful for large variable speed wind turbines, because wind speed can change suddenly. When a gust of wind hits a wind turbine, the blades try to speed up, but a synchronous generator is locked to the speed of the power grid and cannot speed up. Therefore large forces are developed in the hub, gearbox, and generator as the power grid pushes back. This causes wear and damage to the mechanism.

If the turbine is allowed to speed up immediately when hit by a wind gust, the stresses are lower and the power from the wind gust is converted to useful electricity. One approach to allowing wind turbine speed to vary is to accept whatever frequency the generator produces, convert it to DC, and then convert it to AC at the desired output frequency using an inverter. This is common for small house and farm wind turbines. But the inverters required for megawatt-scale wind turbines are large and expensive. Doubly fed generators are one solution to this problem. Instead of the usual field winding fed with DC, and an armature winding where the generated electricity comes out, there are two three-phase windings, one stationary and one rotating, both separately connected to equipment outside the generator. Thus the term "doubly fed". One winding is directly connected to the output, and produces 3-phase AC power at the desired grid frequency. The other winding (traditionally called the field, but here both windings can be outputs) is connected to 3-phase AC power at variable frequency. This input power is adjusted in frequency and phase to compensate for changes in speed of the turbine.

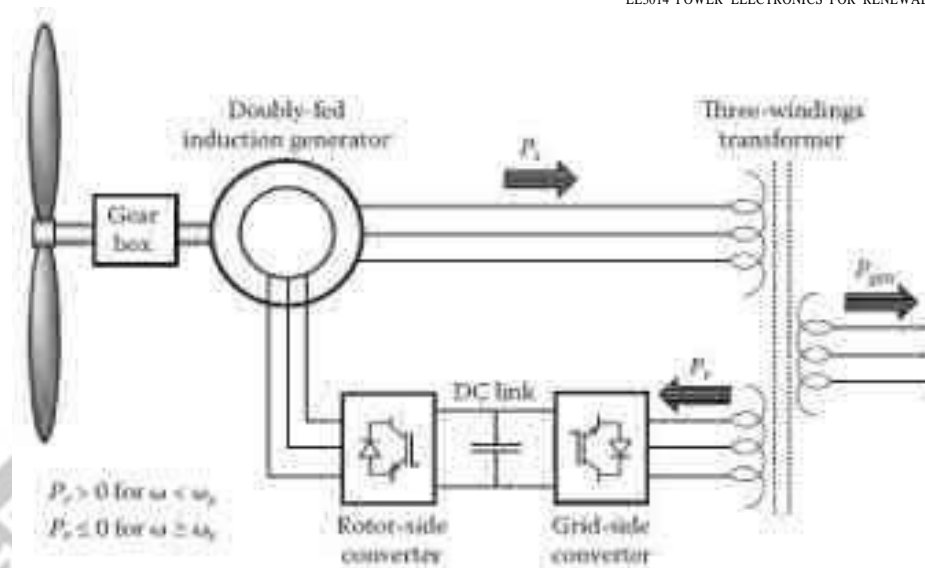

Wind turbine–powered DFIG with transformer-based utility connection

The doubly-fed generator rotors are typically wound with 2 to 3 times the number of turns of the stator. This means that the rotor voltages will be higher and currents respectively lower. Thus in the typical $\pm 30\%$ operational speed range around the synchronous speed, the rated current of the converter is accordingly lower which leads to a lower cost of the converter. The drawback is that controlled operation outside the operational speed range is impossible because of the higher than rated rotor voltage. Further, the voltage transients due to the grid disturbances (three- and two-phase voltage dips, especially) will also be magnified. In order to prevent high rotor voltages - and high currents resulting from these voltages - from destroying the IGBTs and diodes of the converter, a protection circuit (called crowbar) is used.

The crowbar will short-circuit the rotor windings through a small resistance when excessive currents or voltages are detected. In order to be able to continue the operation as quickly as possible an active crowbar has to be used. The active crowbar can remove the rotor short in a controlled way and thus the rotor side converter can be started only after 20-60 ms from the start of the grid disturbance when the remaining voltage stays above 15% of the nominal voltage. Thus it is possible to generate reactive current to the grid during the rest of the voltage dip and in this way help the grid to recover from the fault. For zero voltage ride through it is common to wait until the dip ends because with zero voltage it is not possible to know the phase angle where the reactive current should be injected.

Principle of operation

The principle of the Doubly-Fed Induction Generator (referred to as DFIG) is that rotor windings are connected to the grid via slip rings and back-to-back voltage source converters that control both the rotor and the grid currents. Thus, rotor frequency can freely differ from the grid



frequency (50 or 60 Hz). Double Fed Induction Generator, a generating principle widely used in wind turbines. It is based on an induction generator with a multiphase wound rotor and a multiphase slip ring assembly with brushes for access to the rotor windings. It is possible to avoid the multiphase slip ring assembly but there are problems with efficiency, cost and size.

A doubly-fed induction machine is a wound-rotor doubly-fed electric machine and has several advantages over a conventional induction machine in wind power applications. First, as the rotor circuit is controlled by a power electronics converter, the induction generator is able to both import and export reactive power. This has important consequences for power system stability and allows the machine to support the grid during severe voltage disturbances. Second, the control of the rotor voltages and currents enables the induction machine to remain synchronized with the grid while the wind turbine speed varies. A variable speed wind turbine utilizes the available wind resource more efficiently than a fixed speed wind turbine, especially during light wind conditions. Third, the cost of the converter is low when compared with other variable speed solutions because only a fraction of the mechanical power, typically 25-30%, is fed to the grid through the converter, the rest being fed to grid directly from the stator. The efficiency of the DFIG is very good for the same reason. Doubly-fed electric machine is connected to a selection of resistors via multiphase slip rings for starting. However, the slip power was lost in the resistors. Thus means to increase the efficiency in variable speed operation by recovering the slip power were developed.

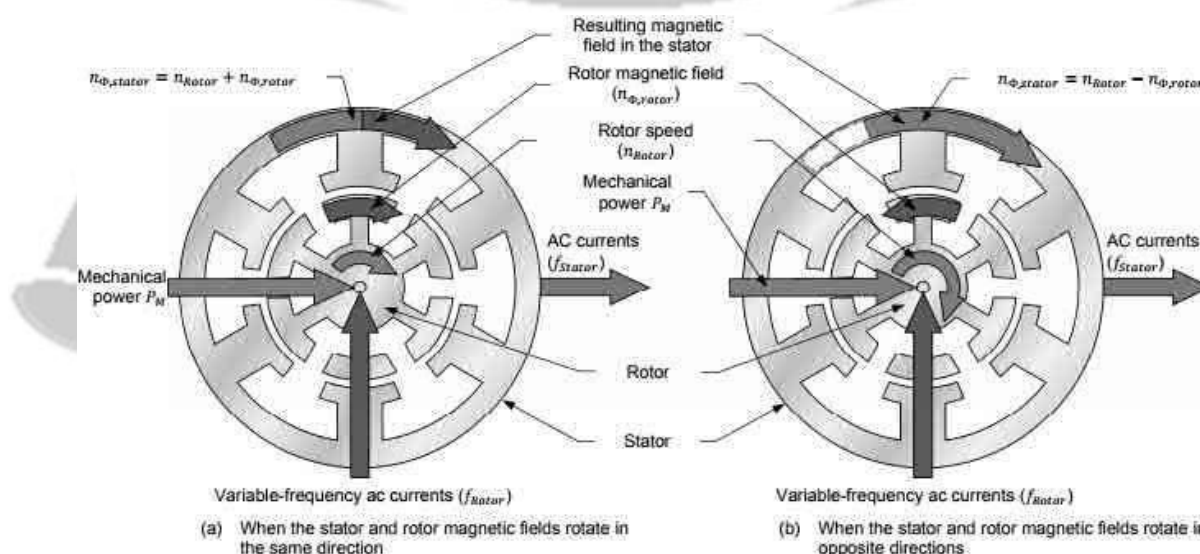

Interaction between the rotor speed and the frequency of the rotating magnetic field created in the rotor windings of a doubly-fed induction generator.

By using the converter to control the rotor currents, it is possible to adjust the active and reactive power fed to the grid from the stator independently of the generator's turning speed. The control principle used is either the two-axis current vector control or direct torque control. Direct



torque control has turned out to have better stability than current vector control especially when high reactive currents are required from the generator.

Equivalent Circuit of DFIG

A doubly fed induction generator is basically a wound rotor induction generator fed by both stator and rotor, in which the stator winding is directly connected to the grid and the rotor winding is connected to the grid through AC/DC/AC converters. These converters are divided into two components: the rotor side converter and the grid side converter. A capacitor between the converters plays a role of a DC voltage source. A coupling inductor is used to link the grid side converter to the grid.

The operation principle of DFIG is fundamentally the same as that of a transformer. Thus, DFIG can be represented as a transformer's per phase equivalent circuit, where R_r and X_r represent rotor resistance and reactance referred to the stator side. But the equivalent circuit of induction machine differs from a transformer's primarily with respect to varying rotor frequency on the rotor voltage. In case of DFIG, there is a voltage injected to the rotor winding, so an equivalent circuit of classic induction machine needs to be modified by adding a rotor injected voltage as shown in Figure. In this figure, s is the rotor slip, V the voltage, I the current, R and X represent resistance and reactance, respectively. The subscripts r , s and m stand for rotor, stator and mutual, respectively.

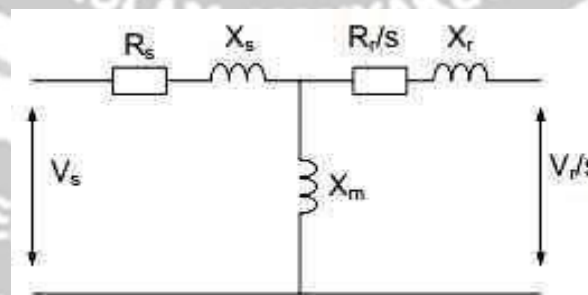

The Equivalent Circuit of DFIG

Real and reactive power in the stator side like P_s and Q_s delivered to the connected grid can be derived from I_s and V_s as in (1):

$$\begin{aligned} P_s &= 3\text{Re}(V_s I_s^*) \\ Q_s &= 3\text{Im}(V_s I_s^*) \end{aligned} \quad (1)$$

Real and reactive power in the rotor side, P_r , Q_r , referred to stator side is derived from I_r and V_r/s , as in (2):

$$P_r = 3\text{Re}\left(\frac{V_r}{s} I_r^*\right)$$



$$Q_r = 3Im\left(\frac{V_r}{s} I_r^*\right) \quad (2)$$

It is possible to express the electromechanical torque, T_e , as in (3):

$$T_e = \frac{3p}{22} Re(j\Psi_s I_s^*) = \frac{3p}{22} Re(j\Psi_r I_r^*) \quad (3)$$

where

$$\Psi_s = \frac{X_s I_s + X_m I_r}{\omega_s}; \quad \Psi_r = \frac{X_r I_r + X_m I_s}{\omega_s}$$

Ψ_s and Ψ_r : the stator and the rotor flux,

respectively. p : the number of poles per phase.

I_s^* , I_r^* : the complex conjugates of the stator and the rotor current, respectively.

Sub- and Super-synchronous modes

Figure (a) shows the power balance in a DFIG at sub-synchronous generation where $s > 0$ and the power flow into the rotor by a current-controlled inverter. A step-up transformer is usually connected between the low-frequency low-voltage requirements and the grid in order to alleviate the rotor converter ratings.

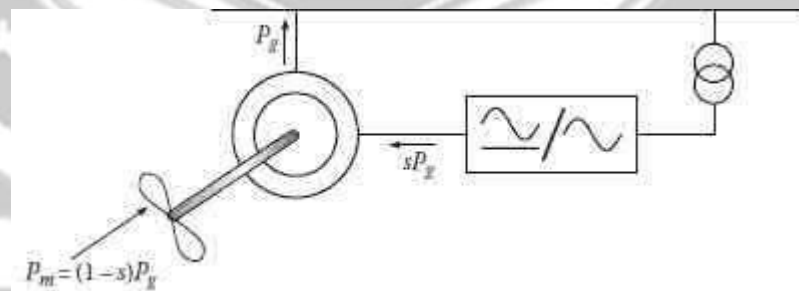

(a) Sub-synchronous generating mode ($s > 0$).

Figure (b) shows the super-synchronous generating mode where the mechanical speed is greater than the electrical synchronous speed, so the slip is negative ($s < 0$). The rotor voltages will have their phase sequence reversed; since $P_g < 0$ and $P_r < 0$, the rotor circuit contributes in generating power to the line with improved efficiency.

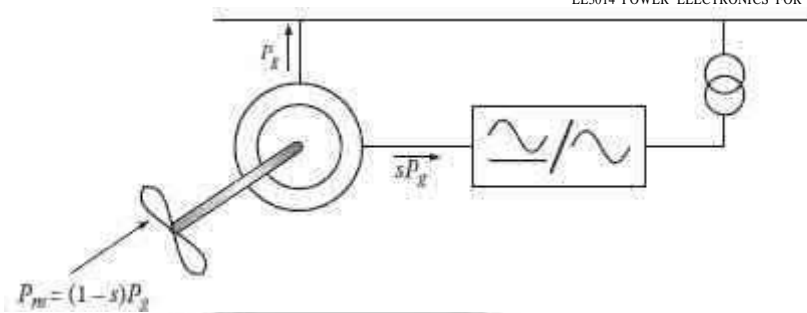

(b) Super-synchronous generating mode ($s < 0$).

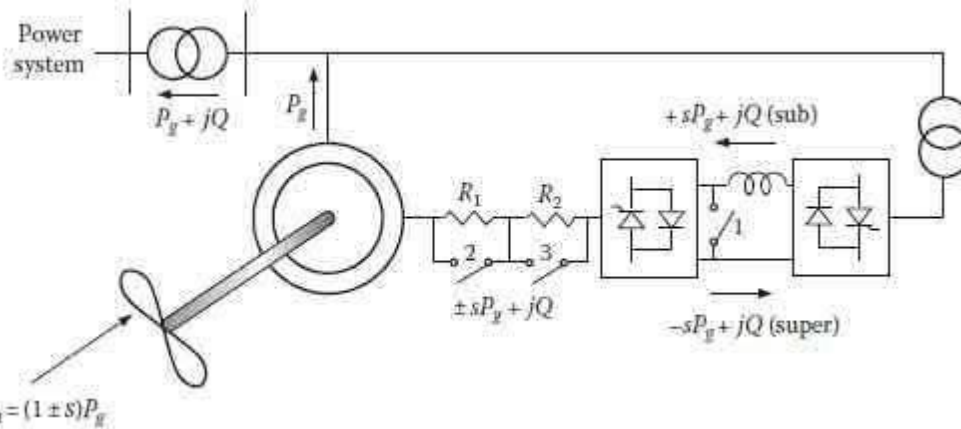

(c) Sub-synchronous mode back-to-back double converter.

It is important to note that the shaft incoming power indicates $P_m = (1 + s)P_g$ to show the extra capability of the power conversion, but the slip is actually negative. Thus, very efficient generating systems can be achieved using the super-synchronous region. Because the operating region is limited, the main drawback is the starting-up sequence of the system. One possible way around this is to use auxiliary resistors in the rotor circuit as indicated in Figure (c), then drive the machine in motoring mode, and, just after the cut-in speed, plug in the controller, which imposes regenerative operation.

Torque-slip curve for DFIG in sub- and super-synchronous modes.

For high-power machines, the stator resistance is neglected, and the stator terminal power is P_g . Considering that the power flowing out of the machine is negative (generating mode), the induction generator has a power balance in accordance with the torque-slip curve indicated in Figure. The power distribution for the generator operating at sub-synchronous and super-synchronous regions is indicated in the operating region from $0.7\omega_s$ to $1.3\omega_s$. For operation at the sub-

synchronous region, the slip is positive, and therefore, the rotor circuit receives power from the line, whereas for the super-synchronous region, the slip is negative, and the rotor power supplements extra generating power to the grid.



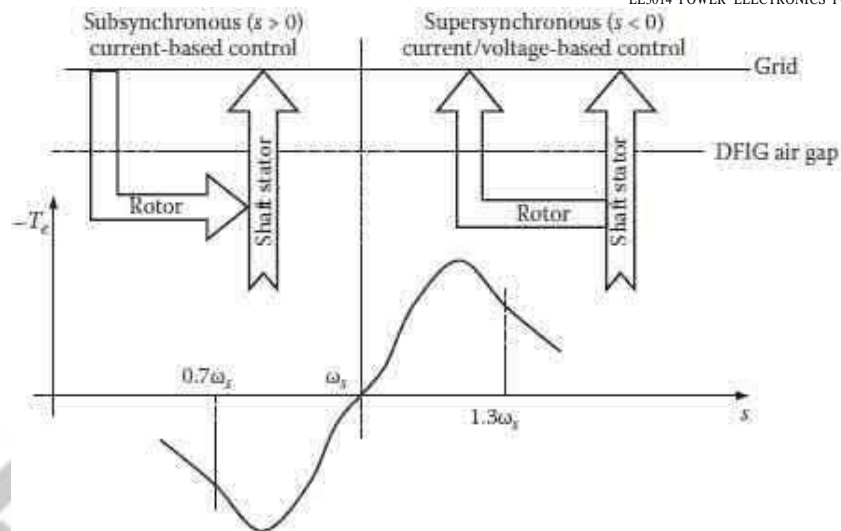

Advantages and disadvantages of DFIG

Advantages

- DFIG is a variable speed generator and therefore has the variable speed advantages compared to fixed speed generators.
- It more fully converts the available wind power over a wider range of wind speeds with less mechanical complexity but more electrical and electronic complexity.
- DFIG provides variable speed with a smaller power converter compared to other variable-speed generators.
- Only the rotor power needs to be converted. That is typically about 30% of the total power.
- Reduced power conversion means reduced losses and increased efficiency. However the converter must be designed to transfer power in either direction, making it more complex than power converters for other types of variable-speed generators.
- The overall equipment, installation and maintenance cost is apparently lower for DFIG systems for some range of power levels.

Disadvantages

- A disadvantage of the DFIG compared to the permanent magnet synchronous generator is that the DFIG requires a speed increasing gearbox between the wind turbine and the generator whereas the PMSG can be constructed with a sufficient number of poles to allow direct drive.

EE6009 POWER ELECTRONICS FOR RENEWABLE ENERGY SYSTEMS
UNIT III-POWER CONVERTERS AND ANALYSIS OF SOLAR PV SYSTEMS

3.1-POWER CONVERTERS: LINE COMMUTATED CONVERTERS (INVERSION-MODE) -
BOOST AND BUCK-BOOST CONVERTERS- SELECTION OF INVERTER, BATTERY SIZING,
ARRAY SIZING.

INTRODUCTION TO POWER CONVERTERS

The task of a power converter is to process and control the flow of electric energy by supplying voltages and currents in a form that is optimally suited for the user loads. Energy was initially converted in electromechanical converters (mostly rotating machines). Today, with the development and the mass production of power semiconductors, static power converters find applications in numerous domains and especially in particle accelerators. They are smaller and lighter and their static and dynamic performances are better. A static converter is a meshed network of electrical components that acts as a linking, adapting or transforming stage between two sources, generally between a generator and a load.

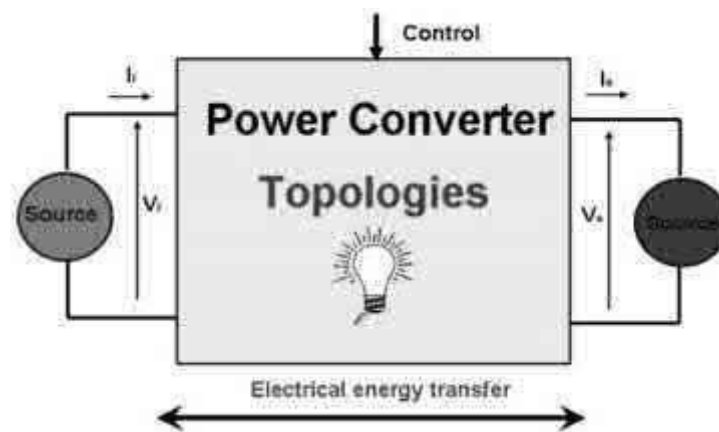

Power converter definition

An ideal static converter controls the flow of power between the two sources with 100% efficiency. Power converter design aims at improving the efficiency. But in a first approach and to define basic topologies, it is interesting to assume that no loss occurs in the converter process of a power converter.

SOLAR PHOTO-VOLTAIC SYSTEM

Introduction

A photovoltaic system, also PV system or solar power system is a power system designed to supply usable solar power by means of photo-voltaic. It consists of an arrangement of several components, including solar panels to absorb and convert sunlight into electricity, a solar inverter to change the electric current from DC to AC, as well as mounting, cabling and other electrical accessories to set up a working system. It may also use a solar tracking system to improve the system's overall performance and include an integrated battery solution, as prices for storage devices are expected to decline. Strictly speaking, a solar array only encompasses the ensemble of solar panels, the visible part of the PV system, and does not include all the other hardware, often summarized as balance of system. Moreover, PV systems convert light directly into electricity and shouldn't be confused with other technologies, such as concentrated solar power or solar thermal, used for heating and cooling.

PV systems range from small, rooftop-mounted or building-integrated systems with capacities from a few to several tens of kilowatts, to large utility-scale power stations of hundreds of megawatts. Nowadays, most PV systems are grid-connected, while off-grid or stand-alone systems only account for a small portion of the market. Operating silently and without any moving parts or environmental emissions, PV systems have developed from being niche market applications into a mature technology used for mainstream electricity generation.

Working and components of a PV system

The solar energy conversion into electricity takes place in a semiconductor device that is called a solar cell. A solar cell is a unit that delivers only a certain amount of electrical power. In order to use solar electricity for practical devices, which require a particular voltage or current for their operation, a number of solar cells have to be connected together to form a solar panel, also called a PV module. For large-scale generation of solar electricity the solar panels are connected together into a solar array. The solar panels are only a part of a complete PV solar system. Solar modules are the heart of the system and are usually called the power generators. One must have also mounting structures to which PV modules are fixed and directed towards the sun.

For PV systems that have to operate at night or during the period of bad weather the storage of energy are required, the batteries for electricity storage are needed. The output of a PV module depends on sunlight intensity and cell temperature; therefore components that condition the DC (direct current) output and deliver it to batteries, grid, and/or load are required for a smooth operation of the PV system. These components are referred to as charge regulators. For applications requiring AC (alternating current) the DC/AC inverters are implemented in PV systems. These additional components form that part of a PV system that is called balance of system. The elements of a PV system are schematically presented in Figure 1.

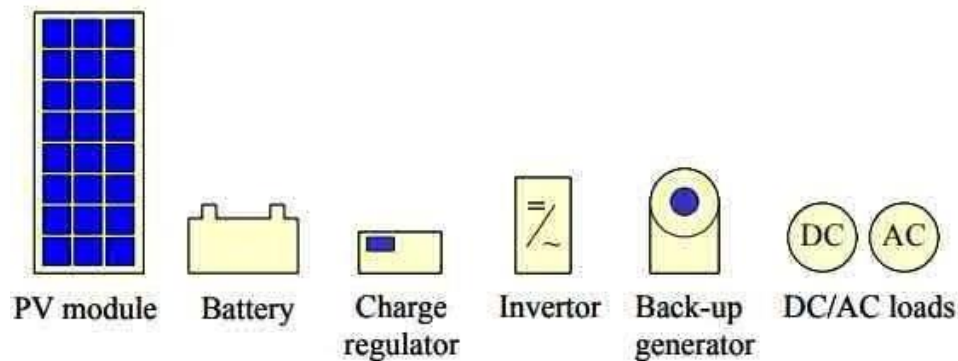

Figure 1: Components of a PV system

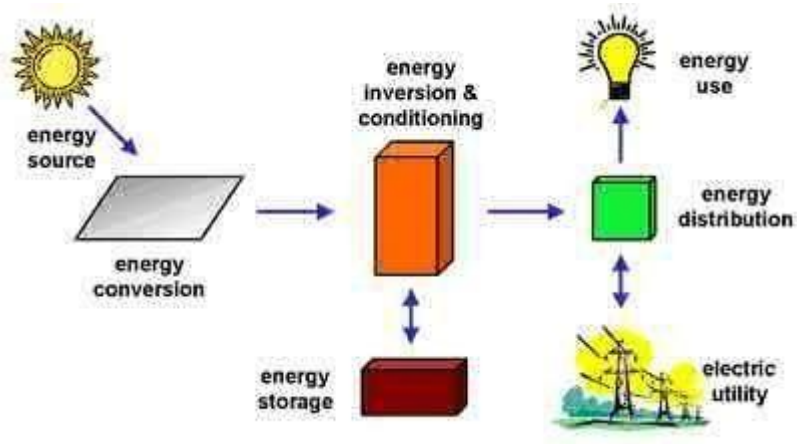

Figure 2: Major photovoltaic system components

Depending on the functional and operational requirements of the system, the specific components required may include major components such as a DC-AC power inverter, battery bank, system and battery controller, auxiliary energy sources and sometimes the specified electrical load (appliances). In addition, an assortment of balance of system hardware, including wiring, over current, surge protection and disconnect devices, and other power processing equipment. Figure 2 show a basic diagram of a photovoltaic system and the relationship of individual components. Batteries are often used in PV systems for the purpose of storing energy produced by the PV array during the day, and to supply it to electrical loads as needed (during the night and periods of cloudy weather). Other reasons batteries are used in PV systems are to

operate the PV array near its maximum power point, to power electrical loads at stable voltages, and to supply surge currents to electrical loads and inverters. In most cases, a battery charge controller is used in these systems to protect the battery from overcharge and over discharge.

PV module and Array

Photovoltaic cells are connected electrically in series and/or parallel circuits to produce higher voltages, currents and power levels. Photovoltaic modules consist of PV cell circuits sealed in an environmentally protective laminate, and are the fundamental building blocks of PV systems. Photovoltaic panels include one or more PV modules assembled as a pre-wired, field- installable unit. A photovoltaic array is the complete power-generating unit, consisting of any number of PV modules and panels.

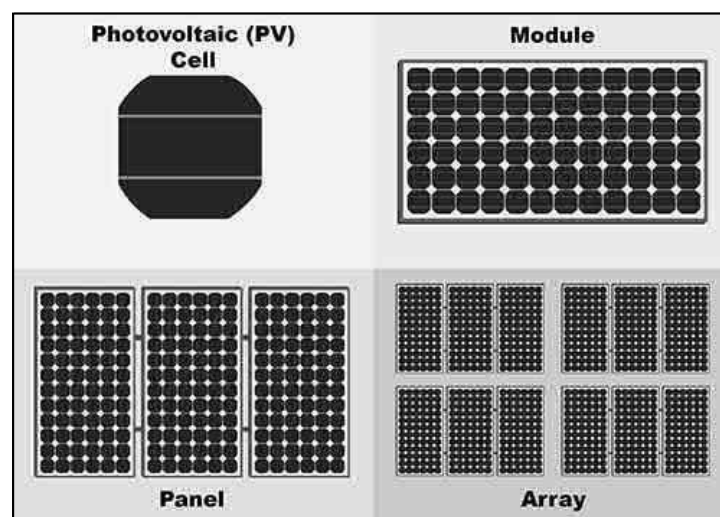

Photovoltaic cells, modules, panels and arrays

Mounting structures

The principal aim of the mounting structures is to hold the PV modules securely in place, which usually means that they have to resist local wind forces. When placed in a public area the structures should prevent stealing the modules. The further common requirements are not to cause shading of the modules and to be arranged so that there is an easy access to the modules for the maintenance or repair. The cost of the structures should be low. For integration in buildings, special mounting structures are being developed that together with the modules serve as building elements.

Energy storage

The simplest means of electricity storage is to use the electric rechargeable batteries, especially when PV modules produce the DC current required for charging the batteries. Most of batteries used in PV systems are lead-acid batteries. In some applications, for example when

used in locations with extreme climate conditions or where high reliability is essential, nickel-cadmium batteries are used. The major difficulty with this form of storage is the relative high cost of the batteries and a large amount required for large-scale application.

Charge regulators

Charge regulators are the link between the PV modules, battery and load. They protect the battery from overcharge or excessive discharge. Charge and discharge voltage limits should be carefully selected to suit the battery type and the operating temperature. These settings can significantly affect maximum operational life of a battery. High temperatures tend to reduce battery life because they accelerate corrosion and self-discharge. High temperatures may also increase outgassing during charging and therefore should be controlled. PV modules that are used to charge batteries usually operate at an approximately constant voltage, which is selected to suit the local temperature. However some PV systems regulators employ a maximum power point tracker (MPPT), which automatically permits the PV modules to operate at the voltage that produces maximum power output. Such regulators employ an electronic DC-DC converter to maintain their output at the required system voltage. The benefit of using an MPPT depends on the application and should be weighed against its additional cost and reliability risks. For many applications, it may be equally or more cost effective to operate the system at a fixed voltage.

Inverters

The inverter's main functions are: transformation of DC electricity into AC, wave shaping of the output AC electricity, and regulation of the effective value of the output voltage. The most important features of an inverter for PV applications are its reliability and its efficiency characteristics. They are designed to operate a PV system continuously near its maximum power point. The technology for high-switching-frequency inverters (typically 20 kHz or higher) is made possible by switch-mode semiconductor power devices. The efficiency of an inverter is normally quoted at its design operating power, but inverters in PV systems typically operate for much of their life at partial loads. For grid-connected operation, inverters must meet the requirements of the utilities concerning acceptable levels of harmonic distortion (quality of voltage and current output waveforms), and should not emit electrical noise, which could interfere with the reception of television or radio. They must also switch off when there is a grid failure for the safety of the engineers who have to repair the grid.

TYPES OF PV SYSTEMS

PV systems can be very simple, just a PV module and load, as in the direct powering of a water pump motor, or more complex, as in a system to power a house. Depending on the system

configuration, we can distinguish three main types of PV systems: stand-alone, grid-connected, and hybrid.

Stand-alone systems

Stand-alone systems depend on PV power only. These systems can comprise only PV modules and a load or can include batteries for energy storage. When using batteries charge regulators are included, which switch off the PV modules when batteries are fully charged, and switch off the load in case batteries become discharged below a limit. The batteries must have enough capacity to store the energy produced during the day to be used at night and during periods of poor weather. Figure 1 shows schematically examples of stand-alone systems.

Grid-connected systems

Grid-connected PV systems have become increasingly popular as building integrated application. They are connected to the grid through inverters, and do not require batteries because the grid can accept all of the electricity that a PV generator can supply. Alternatively they are used as power stations. A grid-connected PV system is schematically presented in Figure 2.

Figure 1: Stand-alone systems

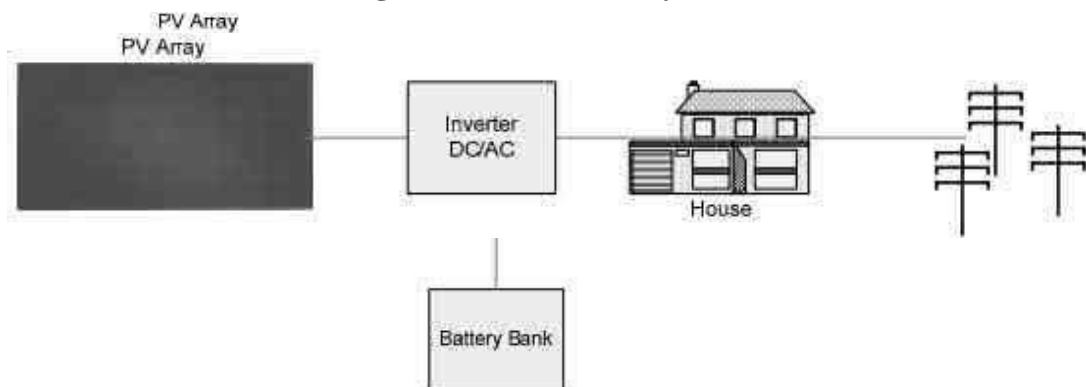

Figure 2: Grid-connected systems

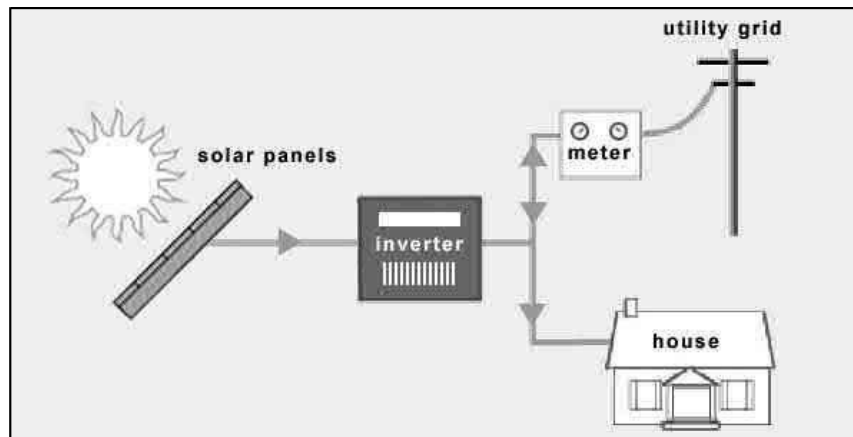

Figure 3: Hybrid PV-Diesel systems

Hybrid systems

Hybrid systems consist of combination of PV modules and a complementary means of electricity generation such as a diesel, gas or wind generator. In order to optimize the operations of the two generators, hybrid systems typically require more sophisticated controls than stand-alone PV systems. For example, in the case of PV/diesel systems, the diesel engine must be started when battery reaches a given discharge level and stopped again when battery reaches an adequate state of charge. The back-up generator can be used to recharge batteries only or to supply the load as well. A common problem with hybrid PV/diesel generators is inadequate control of the diesel generator. If the batteries are maintained at too high a state-of-charge by the diesel generator, then energy, which could be produced by the PV generator, is wasted. Conversely, if the batteries are inadequately charged, then their operational life will be reduced. Such problems must be expected if a PV generator is added to an existing diesel engine without installing an automatic system for starting the engine and controlling its output.

Equivalent circuit diagram of solar PV cell

Now a days, different semiconductor materials i.e. mono crystal polycrystalline and formless silicon are used. The single diode circuit configuration for PV cells is shown in Figure 1 and equation (1) shows the current expression. The double diode circuit configuration for PV cell is shown in Fig.2 and equation (2) shows the current expression.

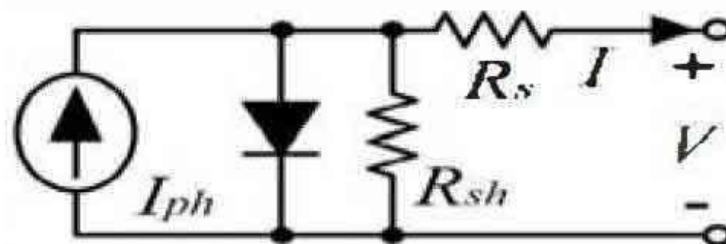

Figure 1: Single diode configuration for PV cell

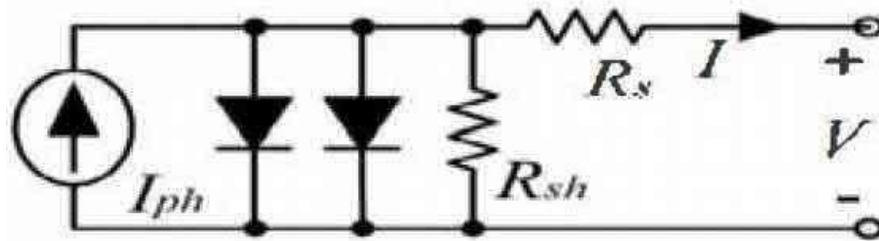

Figure 2: Double diode configuration for PV cell

For temperature dependence I_{ph} will be as shown in equation (3) for maximum power in case of single diode model.

$$I = I_{ph} - I_s \left[e^{\frac{q(V+IR_s)}{N_sKT_0A}} - 1 \right] - \frac{V + IR_s}{R_{sh}} \quad (1)$$

$$I = I_{ph} - I_{s1} \left[e^{\frac{q(V+IR_s)}{A_1KT}} - 1 \right] - I_{s2} \left[e^{\frac{q(V+IR_s)}{A_2KT}} - 1 \right] - \frac{V + IR_s}{R_{sh}} \quad (2)$$

$$I_{ph} = I_{ph(T=298K)} \left[1 + (T - 298K)(5 \times 10^{-4}) \right] \quad (3)$$

$$I_{s1} = K_1 T^3 e^{\frac{-E_g}{KT}} \quad (4a)$$

$$I_{s2} = K_2 T^{\frac{5}{2}} e^{\frac{-E_g}{KT}} \quad (4b)$$

Where

q	=	electron charge = 1.6×10^{-19} V
I_s	=	diode saturation current
I_{ph}	=	Photon Current
K_1	=	$12000 \text{ A/m}^2\text{K}^3$
K_2	=	$2.9 \times 10^9 \text{ A/m}^2\text{K}^{5/2}$
R_s	=	Series Resistance
R_{sh}	=	Shunt Resistance
A	=	Diode ideality Factor
T_0	=	Operating temperature
N_s	=	No. of cells in series
K	=	Boltzmann constant = 1.38×10^{-23} J/K

Low shunt resistance causes power losses in solar cells by providing an alternate current path for the light-generated current. Such a diversion reduces the amount of current flowing through the solar cell junction and reduces the voltage from the solar cell. The effect of a shunt resistance is particularly more at low irradiance, since there will be less magnitude of current. The loss of this current to the shunt therefore has a larger impact. In addition, at lower voltages where the effective resistance of the solar cell is high, the impact of a resistance in parallel is large. For the rise of series resistance the voltage and current density will be reduced and vice versa. For ideal solar plate R_s will be zero and the R_{sh} will be infinite. Therefore, for the

maximum power from the solar PV cell R_s will be negligible value and the R_{sh} must have a higher value.

For maximum power in case of single diode model

$$\frac{dP_m}{dV_m} = \left[I_{ph} - I_{rs} \left[e^{\frac{q(V+qIR_s)}{N_sKT_0A}} - 1 \right] - \left[\frac{V + IR_s}{R_{sh}} \right] + V_m \left[-\frac{q}{N_sKT_0A} I_{rs} \left[e^{\frac{q(V+qIR_s)}{N_sKT_0A}} \right] - \frac{1}{R_{sh}} \right] \right] = 0 \quad (5)$$

Characteristics of PV array and MPP

Solar Cell V-I Characteristics Curves are basically a graphical representation of the operation of a solar cell or module summarizing the relationship between the current and voltage at the existing conditions of irradiance and temperature. *V-I* curves provide the information required to configure a solar system so that it can operate as close to its optimal peak power point (MPP) as possible.

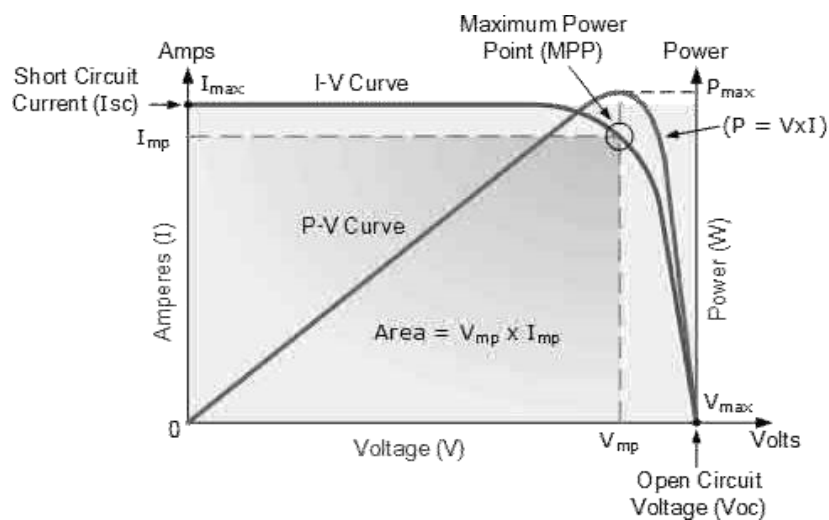

The above graph shows the *V-I* characteristics of a typical silicon PV cell operating under normal conditions. The power delivered by a solar cell is the product of current and voltage. If the multiplication is done, point for point, for all voltages from short-circuit to open-circuit conditions, the power curve above is obtained for a given radiation level. With the solar cell open-circuited that is not connected to any load the current will be at its minimum (zero) and the voltage across the cell is at its maximum, known as the solar cells **open circuit voltage**, or V_{oc} . At the other extreme, when the solar cell is short circuited, that is the positive and negative leads connected together, the voltage across the cell is at its minimum (zero) but the current flowing out of the cell reaches its maximum, known as the solar cells **short circuit current**, or I_{sc} .

Solar Panel I-V Characteristic Curves

Photovoltaic panels can be wired or connected together in either series or parallel combinations, or both to increase the voltage or current capacity of the solar array. If the array panels are connected together in a series combination, then the voltage increases and if connected together in parallels then the current increases.

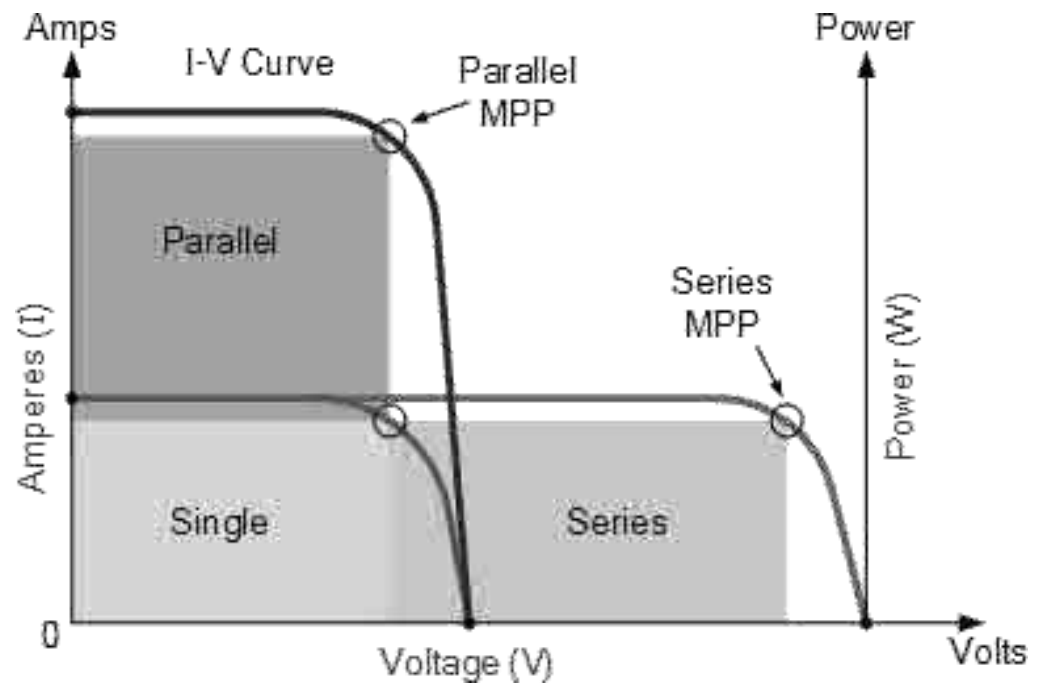

The electrical power in Watts, generated by these different photovoltaic combinations will still be the product of the voltage times the current, ($P = V \times I$). However the solar panels are connected together, the upper right hand corner will always be the maximum power point (MPP) of the array.

Open circuit voltage and short circuit current of PV system

Open-Circuit Voltage

The open-circuit voltage, V_{OC} , is the maximum voltage available from a solar cell, and this occurs at zero current. The open-circuit voltage corresponds to the amount of forward bias on the solar cell due to the bias of the solar cell junction with the light-generated current.

Short-Circuit Current

The short-circuit current is the current through the solar cell when the voltage across the solar cell is zero (i.e., when the solar cell is short circuited). Usually written as I_{SC} , the short-circuit current is shown on the V-I curve below.

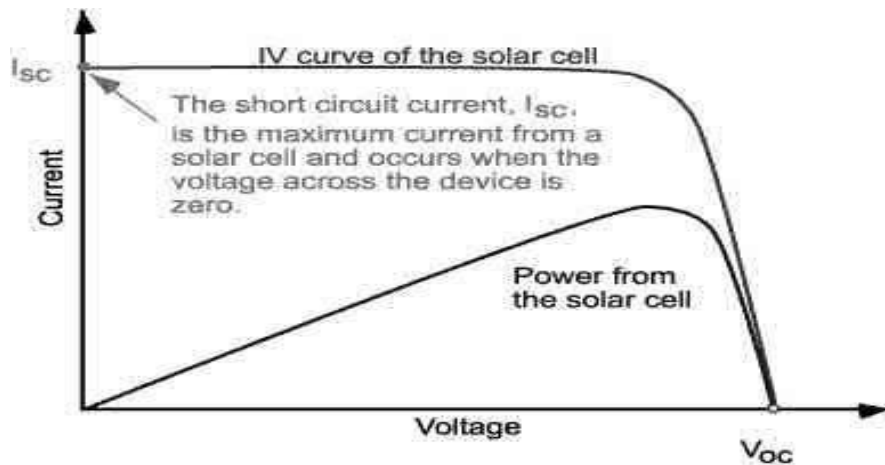

Short-Circuit Current

The short-circuit current is due to the generation and collection of light-generated carriers. For an ideal solar cell at most moderate resistive loss mechanisms, the short-circuit current and the light-generated current are identical. Therefore, the short-circuit current is the largest current which may be drawn from the solar cell.

MPPT

Maximum power point tracking is often called as MPPT. This is an electronic system which commands a solar panel or a set of solar panels to generate the maximum amount of power. The MPPT is not a physical system strapped with solar trackers that position the panels so that they remain under the sun at all times. Although they can be used along with solar trackers, you must know that both are different systems. This fully electronic system varies the electrical operating point of the panels which enables them to deliver the maximum power. The Extra power generated by the panels is made available to the modules in the form of increased battery charging current.

PV POWER CONDITIONING SYSTEM

This is a power converter which interfaces the PV to utility grid and converts the DC supply from the PV plant to AC supply as requirement by the utility grid. Based on the galvanic connection between PV plant and grid, the power conditioning system (PCS) can be broadly classified into two types such as **isolated power conditioning system** and **non isolated power conditioning system**.

Isolated PV Power Conditioning System

In isolated type PV system the isolation between PV plant and grid is achieved by using a line frequency transformer at the output of the inverter (AC side) or by using high frequency transformer DC-DC converter at the input side of the inverter. In low frequency (power

frequency) transformer system involves huge size, increasing magnetic loss and low efficiency than high frequency transformer based DC-DC converter system. This high frequency transformer involves complex control resonant problems and which increase the cost of the PV system.

Non Isolated PV Power Conditioning System

The non isolated grid connected PV system is again classified in to single-stage and multistage power conditioning systems. In single-stage, only one power processing stage is available to convert the PV power to AC supply. Nowadays, single stage power converters are most widely used in PV applications. The single- stage inverter can perform the buck, boost, and both buck- boost input voltage, inversion and maximum power point. The single-stage inverter has the advantages of improved efficiency, low cost, more reliability, modularity, and compact size than multistage power conversion systems.

Figure 1 shows a block diagram of conventional photovoltaic power conditioning systems. They consist of an inverter, LP-filter and line transformer. The filter eliminates/attenuates the harmonics on produced by the inverter, the filter output is stepped up at the grid level by a low frequency transformer.

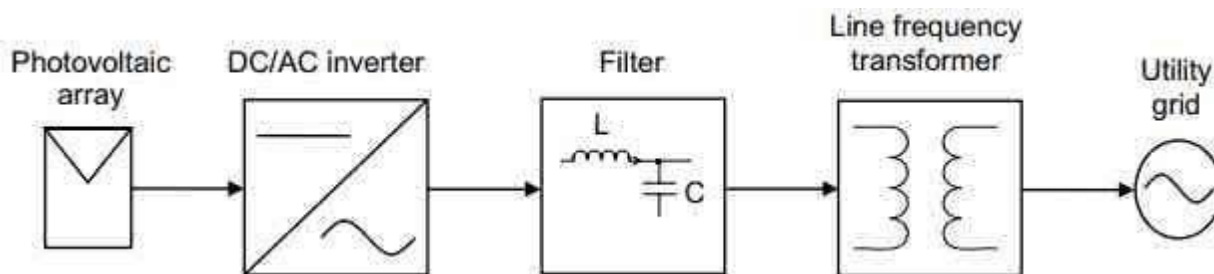

Figure 1: PV PCS with line frequency transformer

Figure 2 shows a block diagram of a conventional isolated type photovoltaic power conditioning system. In this system, a DC/DC converter using a high frequency transformer converts a DC voltage delivered by the PV into a controlled DC voltage suitable for the inverter.

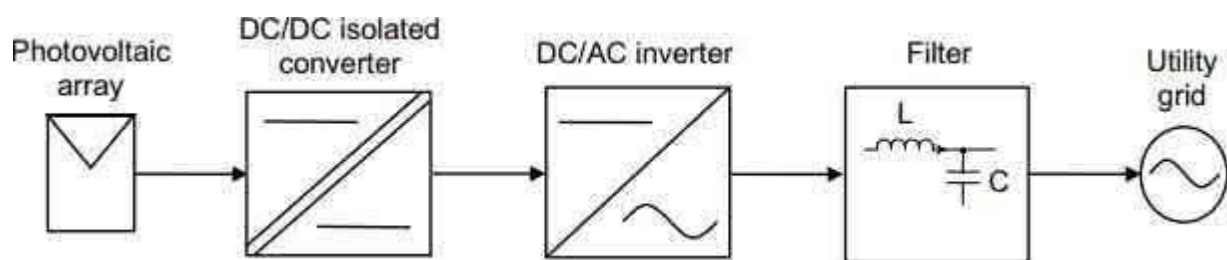

Figure 2: PV PCS with high frequency transformer

Figure 3 shows a block diagram of a conventional non-isolated type photovoltaic power conditioning system. In this system, a DC/DC non-isolated converter receives the fluctuating DC voltage delivered by the PV and converts it into DC voltage suitable for the inverter.

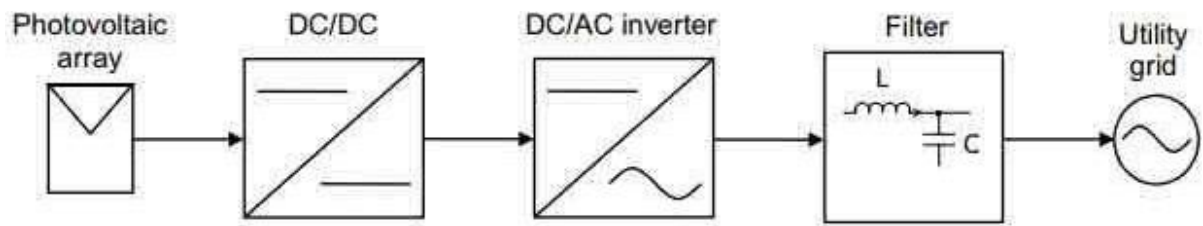
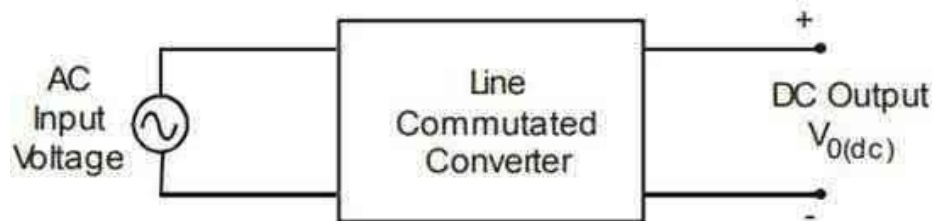

Figure 3: Conventional non-isolated type PV PCS

EE6009 POWER ELECTRONICS FOR RENEWABLE ENERGY SYSTEMS**UNIT III - POWER CONVERTERS AND ANALYSIS OF SOLAR PV SYSTEMS****3.2 - SIMULATION OF LINE COMMUTATED CONVERTERS, BUCK/BOOST CONVERTERS.****LINE COMMUTATED CONVERTERS****Introduction to Controlled Rectifiers**

Controlled rectifiers are line commutated ac to dc power converters which are used to convert a fixed voltage, fixed frequency ac power supply into variable dc output voltage. Type of input: Fixed voltage, fixed frequency ac power supply. Type of output: Variable dc output voltage. The input supply fed to a controlled rectifier is ac supply at a fixed RMS voltage and at a fixed frequency. We can obtain variable dc output voltage by using controlled rectifiers. By employing phase controlled thyristors in the controlled rectifier circuits we can obtain variable dc output voltage and variable dc (average) output current by varying the trigger angle (phase angle) at which the thyristors are triggered. There are several types of power converters which use ac line commutation. These are referred to as line commutated converters.

Line commutated converters under inversion mode**Single Phase Full Converter**

The circuit diagram of a single phase fully controlled bridge converter is shown in the figure with a highly inductive load and a dc source in the load circuit so that the load current is continuous and ripple free (constant load current operation). The fully controlled bridge converter consists of four thyristors T_1 , T_2 , T_3 and T_4 connected in the form of full wave bridge configuration as shown in the figure. Each thyristor is controlled and turned on by its gating

signal and naturally turns off when a reverse voltage appears across it. During the positive half cycle when the upper line of the transformer secondary winding is at a positive potential with respect to the lower end the thyristors T_1 and T_2 are forward biased during the time interval $\omega t = 0$ to π . As soon as the thyristors T_3 and T_4 are triggered a reverse voltage appears across the thyristors T_1 and T_2 and they naturally turn-off and the load current is transferred from T_1 and T_2 to the thyristors T_3 and T_4 .

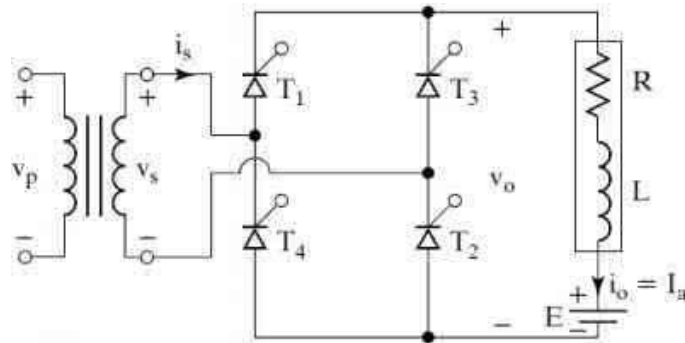

Single Phase Dual Converter

The dual converter system will provide four quadrant operation and is normally used in high power industrial variable speed drives. The converter number 1 provides a positive dc output voltage and a positive dc load current, when operated in the rectification mode. The converter number 2 provides a negative dc output voltage and a negative dc load current when operated in the rectification mode. We can thus have bidirectional load current and bi-directional dc output voltage. The magnitude of output dc load voltage and the dc load current can be controlled by varying the trigger angles of the converters 1 and 2 respectively. There are two modes of operations possible for a dual converter system like non circulating current mode of operation and circulating current mode of operation.

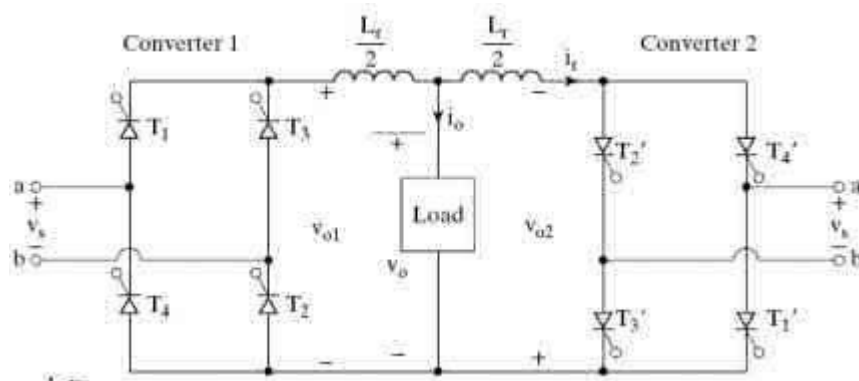

DC-DC Converters

DC-DC Buck Converter

A buck converter (step-down converter) is a DC-to-DC power converter which steps down voltage (while stepping up current) from its input (supply) to its output (load). It is a class

of switched-mode power supply (SMPS) typically containing at least two semi conductors and at least one energy storage element, a capacitor, inductor, or the two in combination. To reduce voltage ripple, filters made of capacitors (sometimes in combination with inductors) are normally added to such a converter's output (load-side filter) and input (supply-side filter).

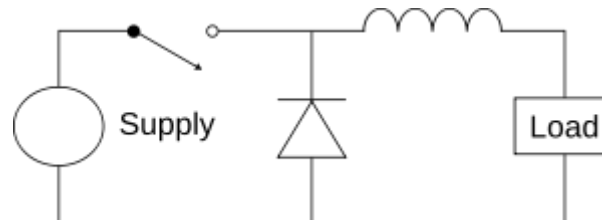

Buck converter circuit diagram.

The basic operation of the buck converter has the current in an inductor controlled by two switches. In the idealized converter, all the components are considered to be perfect. Specifically, the switch and the diode have zero voltage drop when on and zero current flow when off, and the inductor has zero series resistance.

DC-DC Boost Converters

A boost converter (step-up converter) is a DC-to-DC power converter that steps up voltage (while stepping down current) from its input (supply) to its output (load). It is a class of switched-mode power supply (SMPS) containing at least two semiconductors (a diode and a transistor) and at least one energy storage element: a capacitor, inductor, or the two in combination. To reduce voltage ripple, filters made of capacitors (sometimes in combination with inductors) are normally added to such a converter's output (load-side filter) and input (supply-side filter).

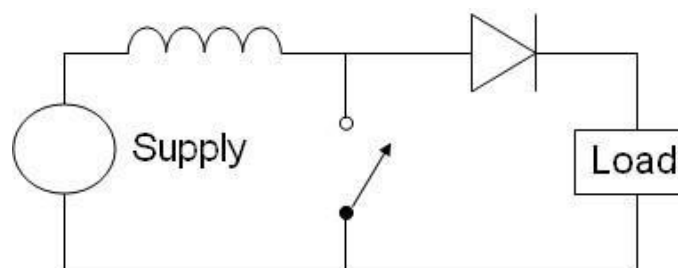

Basic schematic of a boost converter

The key principle that drives the boost converter is the tendency of an inductor to resist changes in current by creating and destroying a magnetic field. In a boost converter, the output voltage is always higher than the input voltage. When the switch is closed, current flows through the inductor in clockwise direction and the inductor stores some energy by generating a magnetic field. Polarity of the left side of the inductor is positive. When the switch is opened, current will be reduced as the impedance is higher. The magnetic field previously created will be destroyed to maintain the current towards the load. Thus the polarity will be reversed (means left

side of inductor will be negative now). As a result, two sources will be in series causing a higher voltage to charge the capacitor through the diode D.

DC-DC Buck-Boost Converters

A Buck-Boost converter is a type of switched mode power supply that combines the principles of the Buck Converter and the Boost converter in a single circuit. Like other SMPS designs, it provides a regulated DC output voltage from either an AC or a DC input.

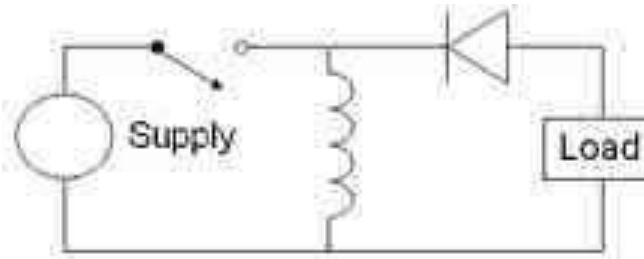

Buck-Boost Converters

It is equivalent to a fly-back using a single inductor instead of a transformer. Two different topologies are called buck–boost converter. Both of them can produce a range of output voltages, ranging from much larger (in absolute magnitude) than the input voltage, down to almost zero.

Modes of Buck Boost Converters

There are two different types of modes in the buck boost converter. The following are the two different types of buck boost converters.

- Continuous conduction mode.
- Discontinuous conduction mode.

Continuous Conduction Mode

In the continuous conduction mode the current from end to end of inductor never goes to zero. Hence the inductor partially discharges earlier than the switching cycle.

Discontinuous Conduction Mode

In this mode the current through the inductor goes to zero. Hence the inductor will totally discharge at the end of switching cycles.

Applications of Buck boost converter

- It is used in the self regulating power supplies.
- It has consumer electronics.
- It is used in the Battery power systems.
- Power amplifier applications.

Advantages of Buck Boost Converter

- It gives higher output voltage.

- Low operating duct cycle.

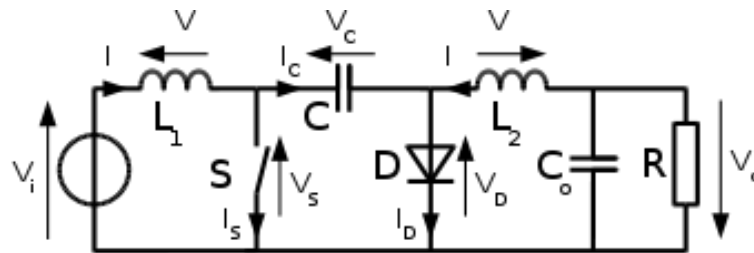
Cuk converter**Schematic of a non-isolated Cuk converter**

The Cuk converter is a type of DC/DC converter that has an output voltage magnitude that is either greater than or less than the input voltage magnitude. It is essentially a boost converter followed by a buck converter with a capacitor to couple the energy. Similar to the buck–boost converter with inverting topology, the output voltage of non-isolated Cuk is typically also inverting, and can be lower or higher than the input. It uses a capacitor as its main energy-storage component, unlike most other types of converters which use an inductor. There are variations on the basic Cuk converter. For example, the coils may share single magnetic core, which drops the output ripple, and adds efficiency. Because the power transfer flows continuously via the capacitor, this type of switcher has minimized EMI radiation. The Cuk converter allows energy to flow bi-directionally by using a diode and a switch.

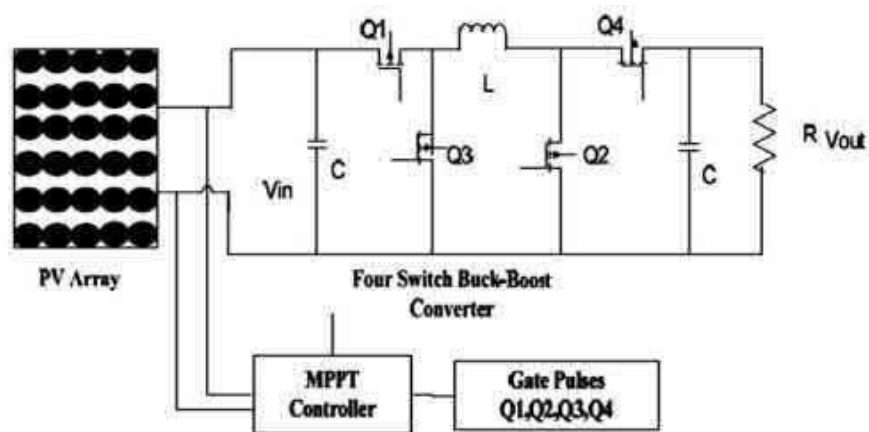
PV fed Buck Boost Converter (Four switched topology)

Four-switch power converter is cascaded combination of Buck converter followed by a Boost converter the converter is different from the other DC-DC converters why, because it has four switches to be controlled, that is, two gate pulses we need. This means for the same working point with different values both gate pulses can be used. Furthermore, due to its simple

and cascaded combination of Buck-Boost structure, it presents high adaptability and high performance to system voltage changes.

The configuration of the system consists of the Solar PV array fed to FSBB Converter which feeds the Load. It is a combination of Buck converter followed by Boost converter; a four switch buck-boost converter can operate in buck mode or boost mode rather than conventional buck-boost converter. As such, its efficiency can be improved by synchronous rectification the power stage consist of four switches (Q_1 , Q_2 , Q_3 , and Q_4), single inductor (L), and input and output Capacitors.

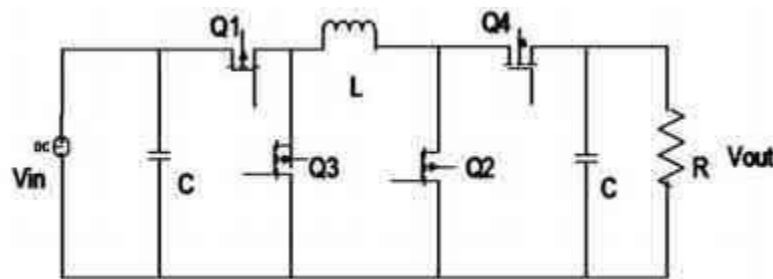

Four-switch buck-boost converter.

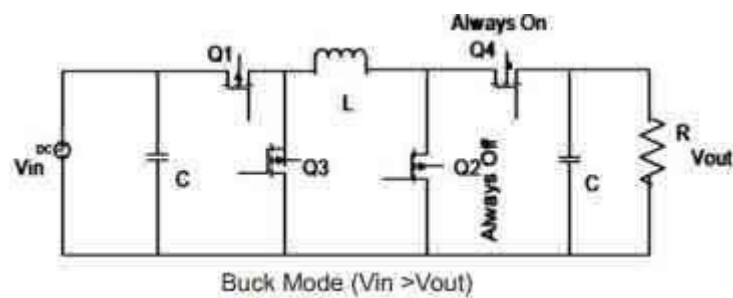

Buck Mode ($V_{in} > V_{out}$)

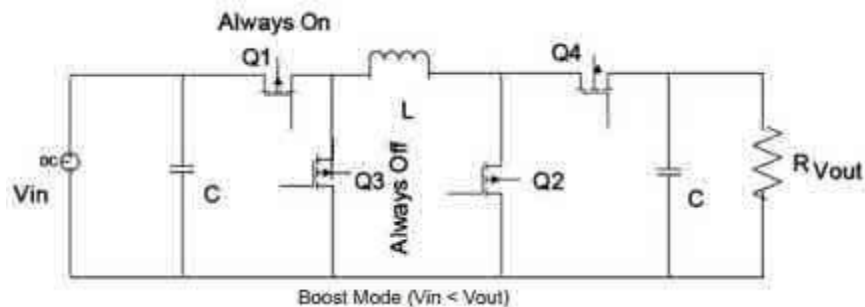

Boost Mode ($V_{in} < V_{out}$)

Equivalent circuit in Buck/Boost mode

Here the MOSFETs Q_3, Q_4 share the gate control signal, which is complementary to the gate control signal of MOSFETs Q_1 and Q_2 . In the buck-boost mode the MOSFETs Q_1 and Q_2 share gate control signals and turn on and off simultaneously. When the MOSFETs Q_1 and Q_2 are turned on, the input voltage V_{in} is applied, the inductor L stores the energy, output capacitor supplies the load current entirely.

When Q_1 and Q_2 are turned off, MOSFETs Q_3, Q_4 are turned on in this stage the energy is transferred from the inductor to output load and capacitor. Here we are using a synchronous rectification scheme these means we are using MOSFETs instead of diodes to reduce the

switching and power losses and to improve efficiency. The Figure shows the equivalent circuit of the converter in buck and boost mode. When V_{in} is higher than V_{out} , The MOSFET Q_2 is always OFF, Q_4 is always ON, Q_1 and Q_3 ON and OFF simultaneously thus it works like a buck converter ($V_{in} > V_{out}$) as shown in below figure. When V_{in} is lower than V_{out} , Q_1 is always ON and Q_3 is always OFF, Q_2 and Q_4 ON and OFF simultaneously it works as a boost converter ($V_{in} < V_{out}$) as shown in below figure.

Current regulated PWM inverters

Current regulation technique plays the most important role in Current Regulated PWM (CR-PWM) inverters which are widely applied in ac motor drives, ac power supply and active filters. The CR-PWM inverters, also known as current mode PWM inverters, implement an on line current feedback (closed loop) type of PWM. In comparison to a conventional feed forward (open loop) voltage controlled PWM inverters they show following advantages: - control of instantaneous peak current, - overload problem is avoided, - pulse drop problem does not occur, - extremely good dynamics, - nearly sinusoidal current waveforms, except for the harmonics - compensation of the effect of load parameter changes (resistance and reactance). The basic problem involved in the implementation of CR-PWM inverters is the choice of suitable current regulation strategy, which affects both the parameters obtained. The main task of the control system in CR-PWM inverter is to force the current vector in the three phase load according to the reference trajectory.

EE6009 POWER ELECTRONICS FOR RENEWABLE ENERGY SYSTEMS**UNIT III****POWER CONVERTERS AND ANALYSIS OF SOLAR PV SYSTEMS****3.3-ANALYSIS: BLOCK DIAGRAM OF THE SOLAR PV SYSTEMS*****SIZING BATTERIES AND INVERTERS FOR A SOLAR PV SYSTEM*****Basics of sizing**

The most important thing that one needs to know before sizing a PV system is the energy requirements of a setup. A few things that can help are:

1. Wattages and counts of all the appliances that need to be run on solar PV.
2. If you do not have wattages then you can look at the current requirement (in amperes) of the appliances and calculate wattage with this simple formula:
Watts = Ampere x 240 (voltage)
3. Electricity bills of the setup. Used to check the monthly electricity units used in a setup. Daily units can be obtained by dividing month units by 28/29/30 or 31 (depending on the number of days in the month for which the bill is generated)

- Daily usage of each appliance in hours. This is required if you do not have a sample electricity bill. This helps in calculating the number of units of electricity used in a day using the formula below: $\text{Units} = (\text{Watts} \times \text{Hours}) \div 1000$

Sizing a PV panel

To size a PV panel, the most essential thing to know is the Total Units consumed in a day by the appliances in a setup. The size of PV system should not be less than the one that can generate total units consumed in a day. Every PV panel has a peak wattage (W_p) mentioned on them. A 1 kW_p (or peak kilo watt) system would generate 5 to 7 units in a day. Thus the right size of PV system (in kW_p) should be estimated by dividing maximum daily usage units divided by 5. If you are going for a grid connected system where extra electricity produced will be sold back to the electricity provider. In such cases you can optimize the size of PV system based on the space that you have for installing PV panels.

Sizing Batteries for PV system

Along with sizing of the PV panel, it is important to size the batteries as well. Because if purchase more batteries then they will not get fully charged, if buy fewer batteries, may not be able to get the maximum benefit out of the solar panel. Most big PV systems use deep cycle (or deep discharge) batteries that are designed to discharge to low energy levels and also to recharge rapidly. These are typically lead acid batteries that may or may not require maintenance. Batteries have energy storage ratings mentioned in Amp-hour (Ah) or milli-Amp-hour (mAh). They also have a nominal voltage that they generate (typically deep discharge batteries are 12 V batteries, cell phone batteries are 5 V batteries, etc). To calculate the total energy a battery can store you can use following formula: $\text{Units} = (\text{Volt} \times \text{Ah}) \div 1000$ or $(\text{Volt} \times \text{mAh}) \div 1000000$. Batteries should be sized in a way that the units of energy generated by the PV system should be equal to the number we have calculated above. So assuming we have a 1 kW_p system and we assume that on an average it generates 6 units a day and if we have to

buy 12 V battery for it, the Ah (or storage) of battery required would be: $(6 \times 1000) \div 12$
= 500 Ah

Sizing Inverter for a Solar PV system

A power inverter or inverter is a system that converts Direct Current (or DC) to an alternating current (or AC). A solar panel produces DC current, batteries also generate DC current, but most systems we use in our daily lives use AC current. Inverters also have transformers to convert DC output voltage to any AC output voltage. Depending on the type of system (grid or off-grid) various types of inverters are available. Sizing of inverter depends on the wattage of appliances connected to it. The input rating of inverter should never be lower than



the total wattages of the appliances. Also it should have the same nominal input voltage as that of the battery setup. It is always better to have inverter wattage about 20-25% more than that of the appliances connected. This is specifically essential if the appliances connected have compressors or motors (like AC, refrigerator, pumps, etc), which draw high starting current. Most inverters available in market are rated on KVA /VA or Kilo Volt Ampere/Volt Ampere. In ideal situations (power factor of 1) $1 \text{ VA} = 1 \text{ Watt}$. But in real power factor varies from 0.85 to 0.99 (more about power factor on: What is Power Factor correction and how MDI (Maximum Demand Indicator) penalty can be avoided). So one can assume $1.18 \text{ VA} = 1 \text{ Watt}$. So if you have a setup where the total wattage of the system is 1000 Watts, it means your inverter size required is more than 1180 VA or 1.18 KVA (add some extra to be on a safer side).



EE6009 POWER ELECTRONICS FOR RENEWABLE ENERGY SYSTEMS**UNIT III-POWER CONVERTERS AND ANALYSIS OF SOLAR PV SYSTEMS****3.4- TYPES OF SOLAR PV SYSTEMS: STAND-ALONE PV SYSTEMS, GRID INTEGRATED****SOLAR PV SYSTEMS - GRID CONNECTION ISSUES.****CLASSIFICATION OF PHOTOVOLTAIC POWER SYSTEMS**

Photovoltaic (PV) systems are playing an increasingly significant role in electricity grids and there have been changes in system configurations in recent years. Classification of PV systems has become important in understanding the latest developments in improving system

performance in energy harvesting. Photovoltaic power systems are generally classified according to their functional and operational requirements, their component configurations, and how the equipment is connected to other power sources and electrical loads. The two principal classifications are grid-connected or utility-interactive systems and stand-alone systems. In general, grid-connected PV power systems can be categorized into two main groups: centralized MPPT (CMPPT) and distributed MPPT (DMPPT). Photovoltaic systems can be designed to provide DC and/or AC power service, can operate interconnected with or independent of the utility grid, and can be connected with other energy sources and energy storage systems.

Diagram of grid-connected photovoltaic system.

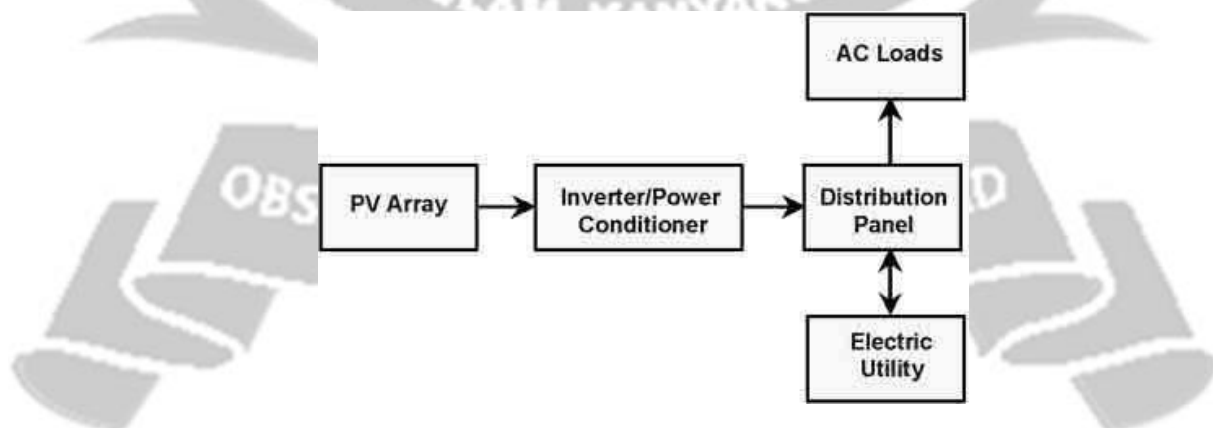

Grid-connected photovoltaic system

Grid-connected or utility-interactive PV systems are designed to operate in parallel with and interconnected with the electric utility grid. The primary component in

grid-connected PV



systems is the inverter, or power conditioning unit (PCU). The PCU converts the DC power produced by the PV array into AC power consistent with the voltage and power quality requirements of the utility grid, and automatically stops supplying power to the grid when the utility grid is not energized. A bi-directional interface is made between the PV system AC output circuits and the electric utility network, typically at an on-site distribution panel or service entrance. This allows the AC power produced by the PV system to either supply on-site electrical loads or to back-feed the grid when the PV system output is greater than the on-site load demand. At night and during other periods when the electrical loads are greater than the PV system output, the balance of power required by the loads is received from the electric utility. This safety feature is required in all grid-connected PV systems, and ensures that the PV system will not continue to operate and feed back into the utility grid when the grid is down for service or repair.

Stand-Alone Photovoltaic Systems

Stand-alone PV systems are designed to operate independent of the electric utility grid, and are generally designed and sized to supply certain DC and/or AC electrical loads. These types of systems may be powered by a PV array only, or may use wind, an engine-generator or utility power as an auxiliary power source in what is called a PV-hybrid system. The simplest type of stand-alone PV system is a direct-coupled system, where the DC output of a PV module or array is directly connected to a DC load.

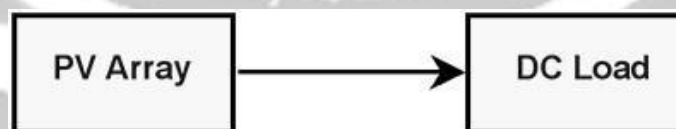

Direct-coupled PV system

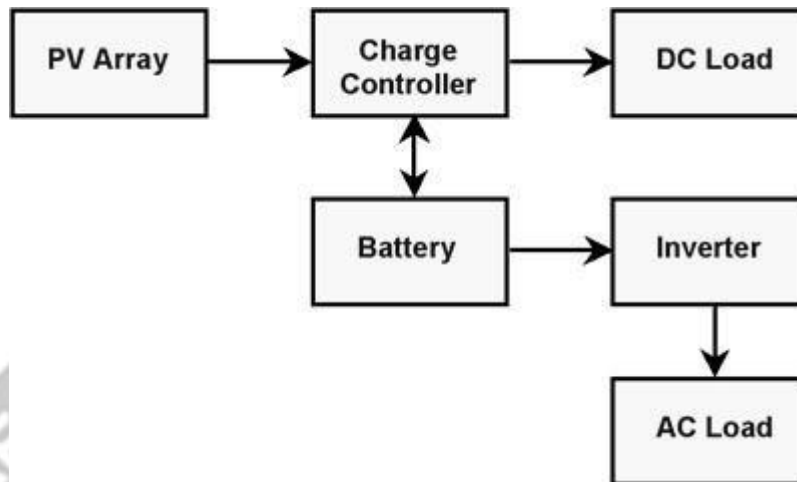

Stand-alone PV system with battery storage powering DC and AC loads

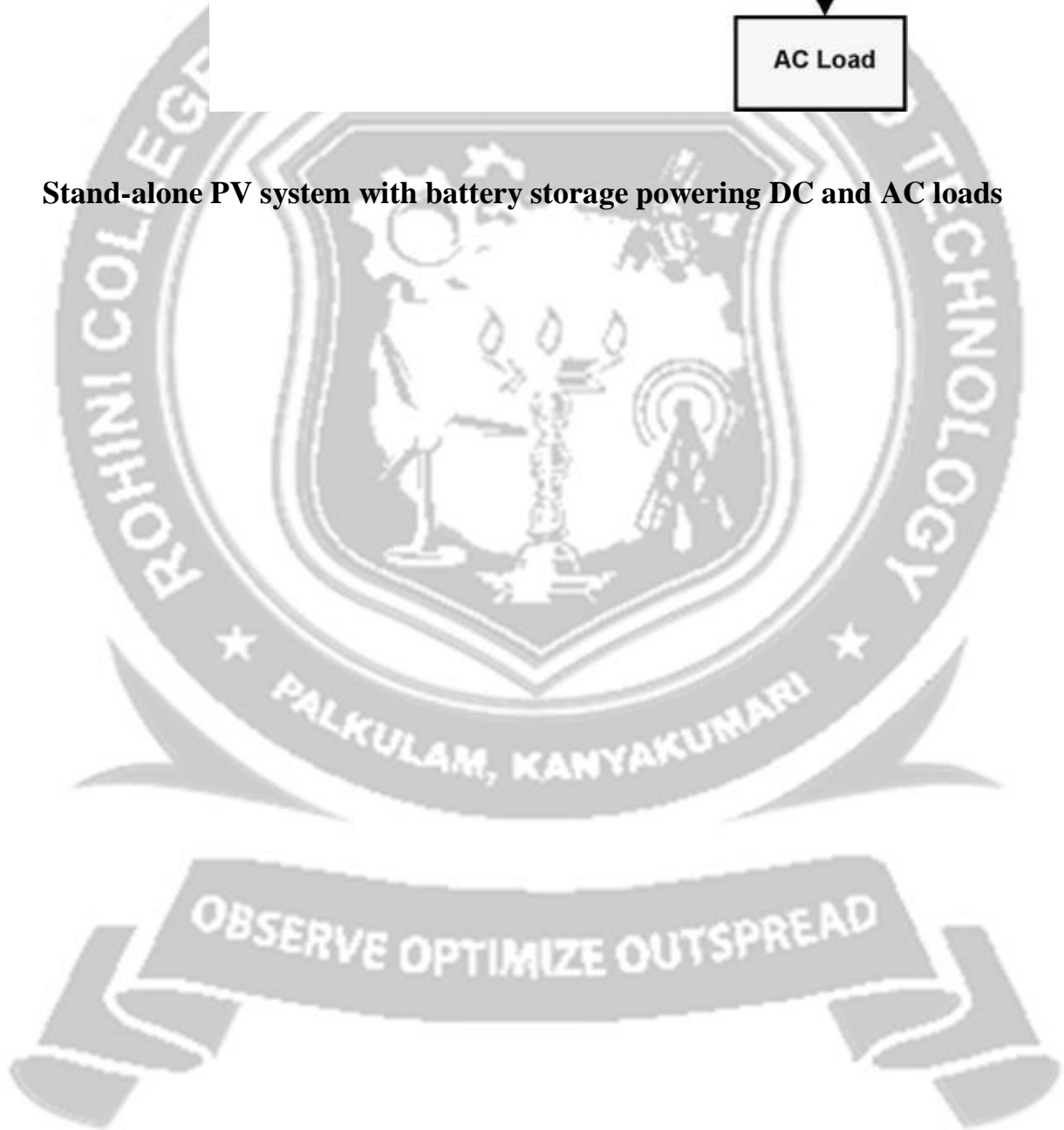

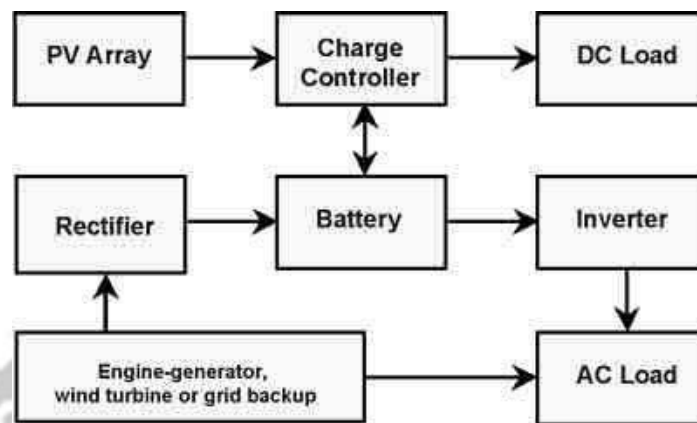

Photovoltaic hybrid system

Since there is no electrical energy storage (batteries) in direct-coupled systems, the load only operates during sunlight hours, making these designs suitable for common applications such as ventilation fans, water pumps, and small circulation pumps for solar thermal water heating systems. Matching the impedance of the electrical load to the maximum power output of the PV array is a critical part of designing well-performing direct-coupled system. For certain loads such as positive-displacement water pumps, a type of electronic DC-DC converter, called a maximum power point tracker (MPPT), is used between the array and load to help better utilize the available array maximum power output.

A Stand Alone Solar PV System

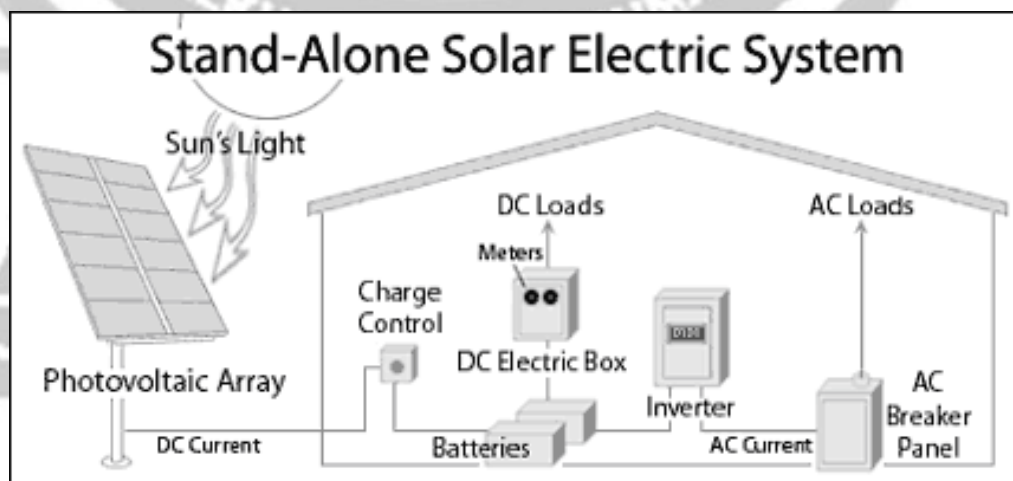

A free standing or **Stand Alone PV System** is made up of a number of individual photovoltaic modules (or panels) usually of 12 volts with power outputs of between 50

and 100+ watts each. These PV modules are then combined into a single array to give the desired power output. A simple *stand alone PV system* is an automatic solar system that produces electrical power to charge banks of batteries during the day for use at night when the sun's energy is unavailable. A stand alone small scale PV system employs rechargeable batteries to store the electrical energy supplied by a PV panels or array. Stand alone PV systems are ideal for remote rural areas and applications where other power sources are either impractical or are unavailable to provide power for lighting, appliances and other uses. In these cases, it is more cost effective

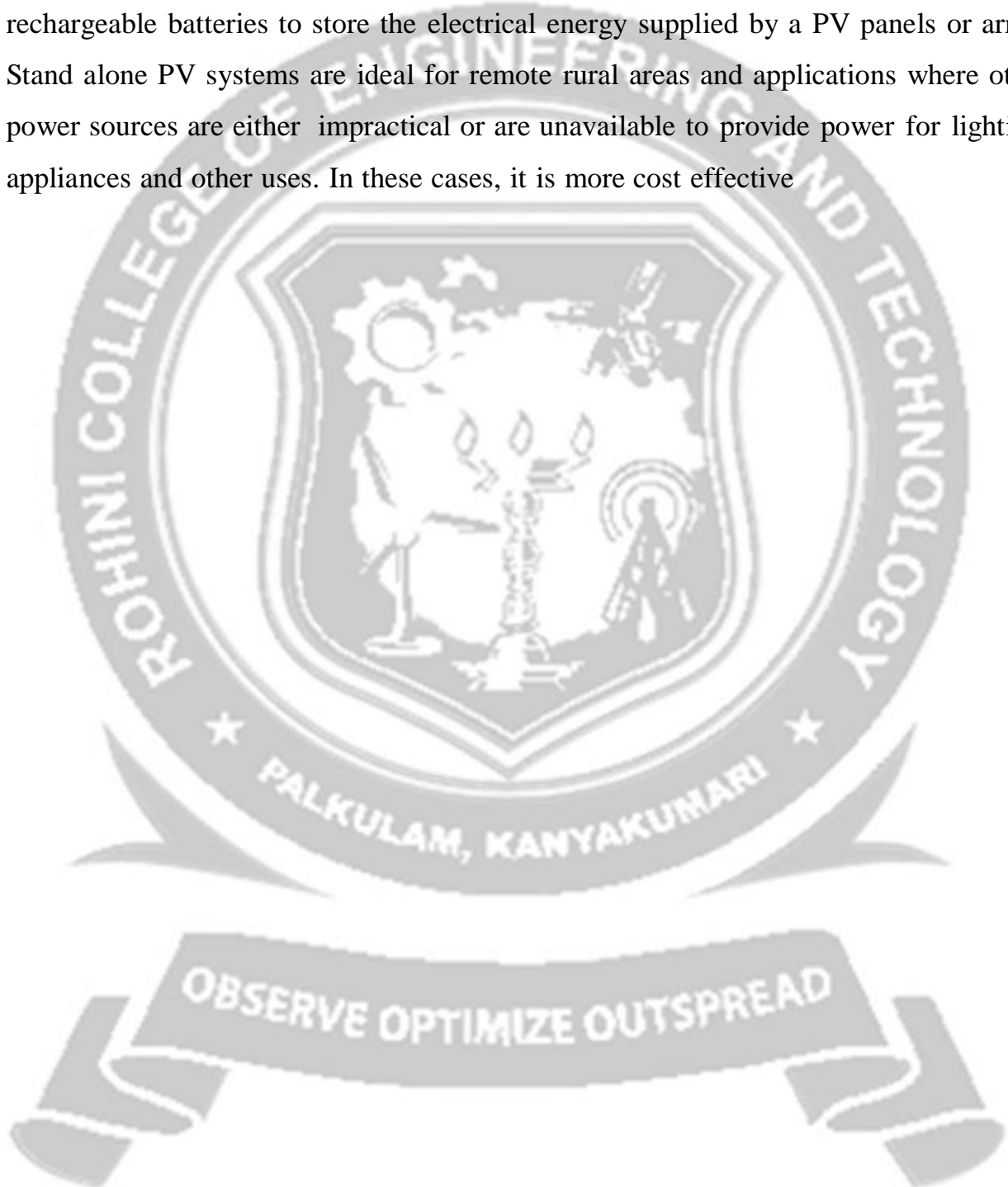

to install a single stand alone PV system than pay the costs of having the local electricity company extend their power lines and cables directly to the home.

A Stand Alone Solar PV System

While a major component and cost of a standalone PV system is the solar array, several other components are typically needed. These include:

Batteries:

Batteries are an important element in any stand alone PV system but can be optional depending upon the design. Batteries are used to store the solar-produced electricity for night time or emergency use during the day. Depending upon the solar array configuration, battery banks can be of 12V, 24V or 48V and many hundreds of amperes in total. Deep cycle lead acid batteries are generally used to store the solar power generated by the PV panels, and then discharge the power when energy is required. Deep cycle batteries are not only rechargeable, but they are designed to be repeatedly discharged almost all the way down to a very low charge.

Charge Controller:

A charge controller regulates and controls the output from the solar array to prevent the batteries from being over charged (or over discharged) by dissipating the excess power into a load resistance. Charge controllers within a standalone PV system are optional but it is a good idea to have one for safety reasons. The charge controller ensures that the maximum output of the solar panels or array is directed to charge the batteries without over charging or damaging them. They operate automatically, with most commercially available charge controllers having a digital display to show how much power has been created at any time, the state of charge of the batteries and programmable settings to discharge the batteries into a resistive dummy load to minimize the chances of sulphation of the battery cells extending the battery life.

Fuses and Isolation Switches:

These allow PV installations to be protected from accidental shorting of wires allowing power from the PV modules and system to be turned -OFF when not required saving energy and improving battery life.

Inverter:

Inverters are used to convert the 12V, 24V or 48 Volts direct current (DC) power from the solar array and batteries into an alternating current (AC) electricity and power of either 120 VAC or 240 VAC for use in the home to power AC mains appliances such as TV's, washing machines, freezers, etc.

Wiring:

The final component required in a PV solar system is the electrical wiring. The cables need to be correctly rated for the voltage and power requirements.



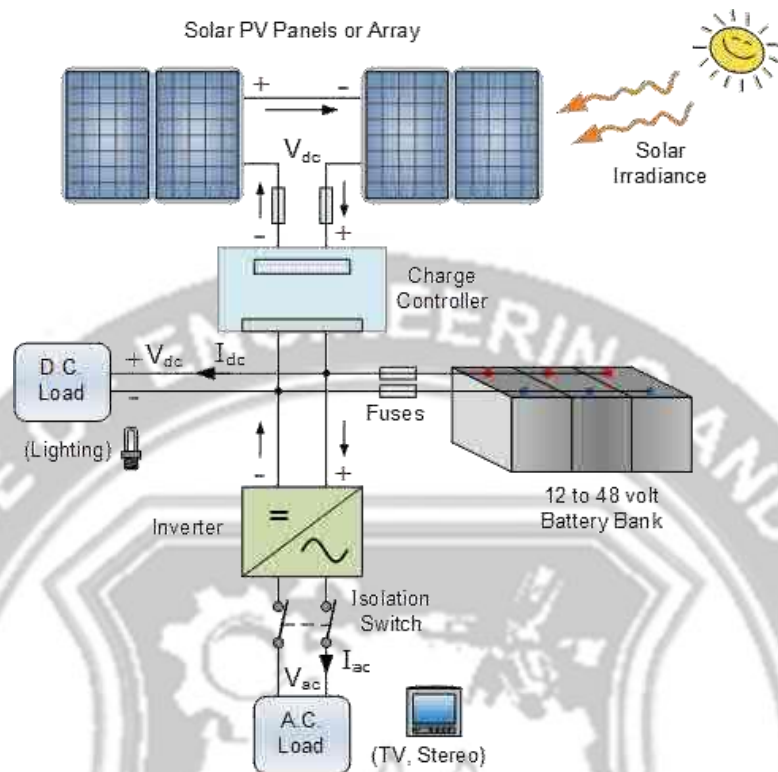

Newer low voltage solar technologies have been implemented in a wide variety of lighting applications. Street lights, security lights, solar garden lights and car park lamps can all be designed with small, built-in solar arrays producing a complete stand alone PV system. Exposed to the sun all day, these lights can retain their electrical charge to keep lit all night long. Electric road signs can take advantage of solar panels in the same way, although vital street and traffic signs on major roads and motorway's also have alternate sources of power as backup.

Important factors in having a standalone PV system

Solar panels only create electricity while the sun is shining on them so it may be necessary to store enough electricity to get through one or two days of cloudy weather. In this case solar electricity becomes a valuable resource, will not want to live without it, but will not want to waste it, either. Try reducing energy demand through energy efficient measures. Purchasing energy saving appliances and LED lights, for example, will reduce electrical demand and allow purchasing a smaller stand alone PV system to meet actual energy needs.

Energy efficiency allows starting small and then adding on as your energy needs increase. Secondly, while a standalone PV system is not a complicated system to install

or run compared with other forms of off grid electrification devices, wind turbines, hydro-electric etc, solar PV systems still require regular maintenance that is not normally associated with standard grid connected mains power.

All the systems components have to be checked and cleaned on a regular basis to make sure that the system is running optimally and like many other off grid systems, PV systems



require some basic electrical knowledge in order to be able to install and maintain them in an effective manner and to diagnose any problems so become an expert of system.

There are many advantages of a standalone PV system some include low maintenance, low upkeep cost, no waste or byproducts, and easy expansion by using multiple solar panels and batteries. The disadvantages include high initial investment, especially for the photovoltaic panels and deep cycle lead acid batteries, reliance on the sun, and the possible danger from battery acid and fumes associated with most forms of renewable energy.



EE3014 POWER ELECTRONICS FOR RENEWABLE ENERGY SYSTEMS

UNIT IV-POWER CONVERTERS FOR WIND SYSTEMS

4.1-STAND POWER CONVERTERS: THREE-PHASE AC VOLTAGE CONTROLLERS.

THREE-PHASE AC VOLTAGE REGULATORS

There are many types of circuits used for the three-phase ac regulators (ac to ac voltage converters), unlike single-phase ones. The three-phase loads (balanced) are connected in star or delta. Two thyristors connected back to back, or a triac, is used for each phase in most of the circuits as described. Two circuits are first taken up, both with balanced resistive (R) load

Three-phase, star connected AC Regulator with Balanced Resistive Load

The circuit of a three-phase, three-wire AC regulator (termed as ac to ac voltage converter) with balanced resistive (star-connected) load is shown in Figure. It may be noted that the resistance connected in all three phases are equal. Two thyristors connected back to back are used per phase, thus needing a total of six thyristors. The current flow is bidirectional, with the current in one direction in the positive half, and then, in other (opposite) direction in the negative half. So, two thyristors connected back to back are needed in each phase. The turning off of a thyristor occurs, if its current falls to zero. To turn the thyristor on, the anode voltage must be higher than the cathode voltage, and also, a triggering signal must be applied at its gate.

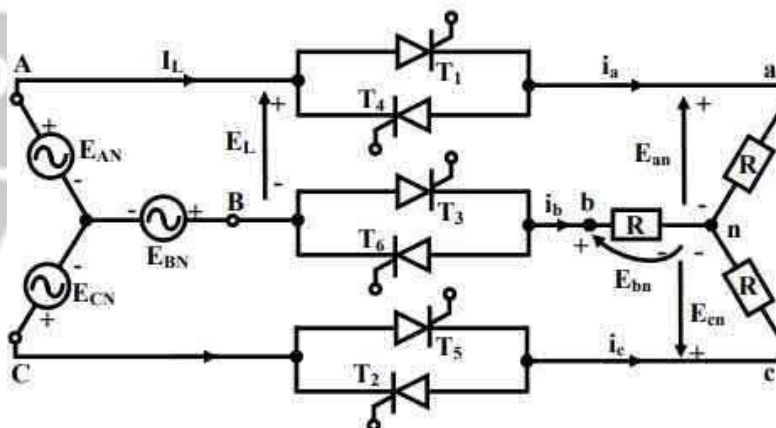

Three-phase, three-wire star connected AC voltage regulator

The expression of the RMS value of output voltage is obtained by per phase for balanced star-connected resistive load which depends on range of firing angle. If is the RMS value of the input voltage per phase, and assuming the voltage, as the reference, the instantaneous input voltages per phase are,

$$e_{AN} = \sqrt{2}E_s \sin \omega t$$

$$e_{BN} = \sqrt{2}E_s \sin (\omega t - 120^\circ)$$

$$e_{CN} = \sqrt{2}E_s \sin (\omega t + 120^\circ)$$

Then, the instantaneous input line voltages are,

$$e_{AB} = \sqrt{6}E_s \sin(\omega t + 30^\circ)$$

$$e_{BC} = \sqrt{6}E_s \sin (\omega t - 90^\circ)$$

$$e_{CA} = \sqrt{6}E_s \sin (\omega t + 150^\circ)$$

Three-phase Delta-connected AC Regulator with Balanced Resistive Load

The circuit of a three-phase, delta-connected ac regulator (termed as ac to ac voltage converter) with balanced resistive load is shown in Figure. It may be noted that the resistance connected in all three phases are equal. Two thyristors connected back to back are used per phase, thus needing a total of six thyristors. As stated earlier, the numbering scheme may be noted. It may be observed that one phase of the balanced circuit is similar to that used for single phase ac regulator. Since the phase current in a balanced three-phase system is only $(1/\sqrt{3})$ of the line current, the current rating of the thyristors would be lower than that if the thyristors are placed in the line.

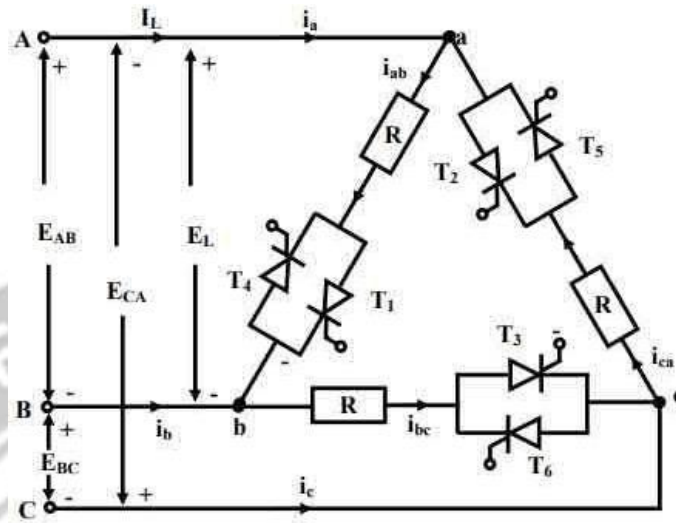

Assuming the line voltage as the reference, the instantaneous input line voltages are,

$$e_{AB} = \sqrt{2}E_s \sin \omega t$$

$$e_{BC} = \sqrt{2}E_s \sin (\omega t - 120^\circ)$$

$$e_{CA} = \sqrt{2}E_s \sin (\omega t + 120^\circ)$$



EE3014 POWER ELECTRONICS FOR RENEWABLE ENERGY SYSTEMS

UNIT IV-POWER CONVERTERS FOR WIND SYSTEMS

4.2-AC-DC-AC CONVERTERS: UNCONTROLLED RECTIFIERS, PWM INVERTERS, GRID-INTERACTIVE INVERTERS - MATRIX CONVERTER

THREE PHASE AC-DC-AC CONVERTERS (THE BACK-TO-BACK CONVERTER)

The back-to-back converter consists simply of a force-commutated rectifier and a force-commutated inverter connected with a common dc-link shown in figure. The properties of this combination are well known; the line-side converter may be operated to give sinusoidal line currents, for sinusoidal currents, the dc-link voltage must be higher than the peak main voltage, the dc-link voltage is regulated by controlling the power flow to the ac grid and, finally, the inverter operates on the boosted dc-link, making it possible to increase the output power of a connected machine over its rated power. Another advantage in certain applications is that braking energy can be fed back to the power grid instead of just wasting it in a braking resistor.

An important property of the back-to-back converter is the possibility of fast control of the power flow. By controlling the power flow to the grid, the dc-link voltage can be held constant. The presence of a fast control loop for the dc-link voltage makes it possible to reduce the size of the dc-link capacitor, without affecting inverter performance. In fact, the capacitor can be made small enough to be implemented with plastic film capacitors.

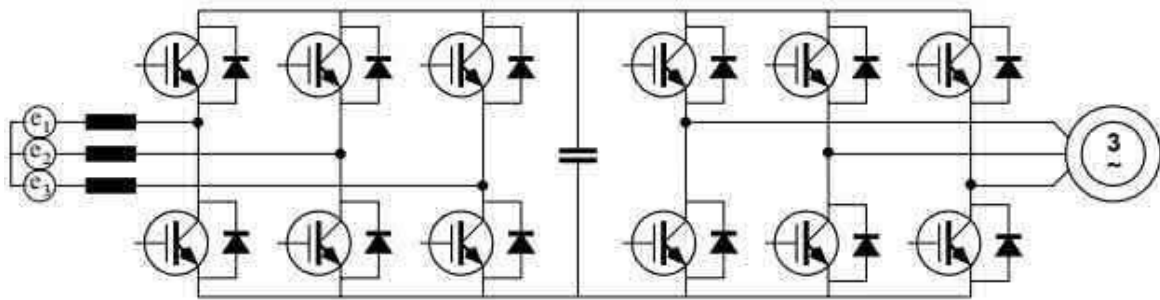

Back-to-back converter

Issues associated with a small DC-link capacitor

Smallest size of the dc-link capacitor is governed by the need to keep the switch-frequency ripple at acceptable (i.e. small) levels. Fluctuations in the load cannot be smoothed in the converter, but must be accommodated by other means. One alternative is to simply transfer such fluctuations to the power grid, but this may re-introduce the line-current harmonics the back to back converter is supposed to eliminate. However, load fluctuations will be random and thus relatively harmless compared to the in-phase harmonics generated by diode rectifiers. Another alternative is to use the load itself. In a typical drive, the mechanical energy stored in the drive is several orders of magnitude larger than the electrical energy stored in the DC-link capacitor in a back-to-back converter. If the application does not need servo-class performance, there is no reason why the rotational speed cannot be allowed to fluctuate slightly.

Application criteria for three-phase nine-switch converters

The nine-switch topology is derived from two converters connected back-to-back (BTB) shown in figure. Two phase legs from converter 1 and 2, respectively, are merged together to compose one phase leg of the nine switch converter, and meanwhile one switch is dismissed. Thus nine-switch converters have only three phase legs and each of them has only three switches.

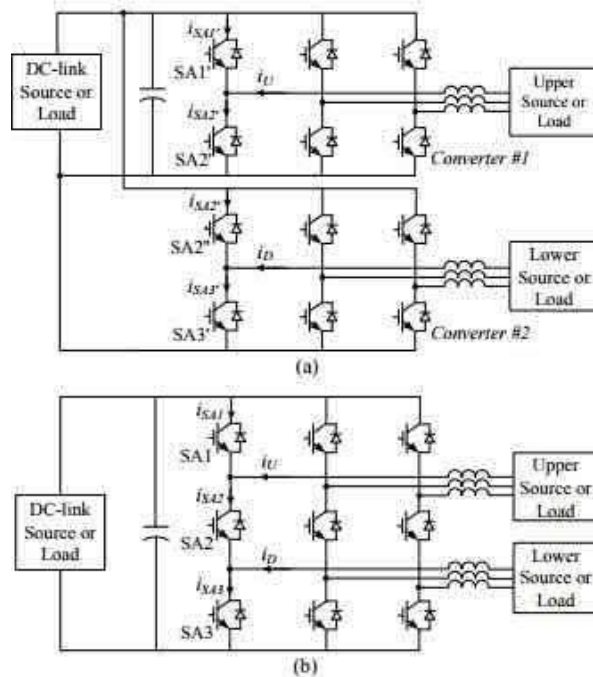

Nine-switch power converters

With such a topology, nine-switch converters retain the DC-link and can achieve all the functions of twelve-switch BTB even with three switches less.

UNCONTROLLED RECTIFIERS

Half Wave Rectifier Circuit

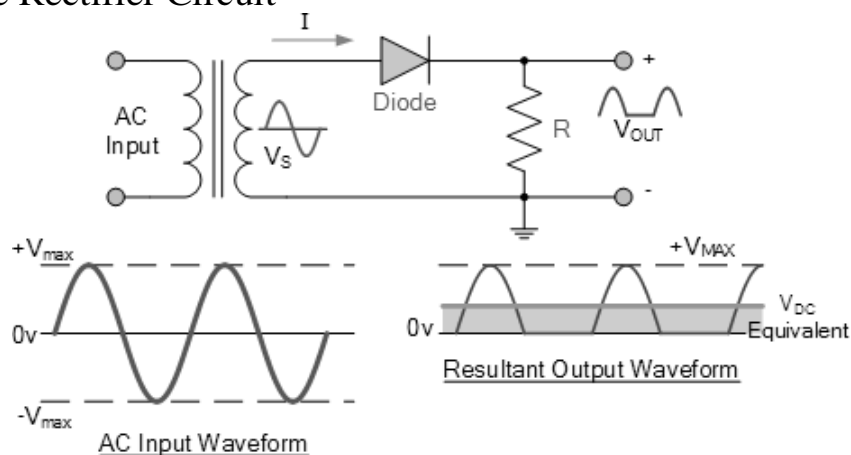

A rectifier is a circuit which converts the *Alternating Current* (AC) input

power into a *Direct Current* (DC) output power. The input power supply may be either a single-phase or a multi-phase supply with the simplest of all the rectifier circuits being that of the **Half Wave Rectifier**. The power diode in a half wave rectifier circuit passes just one half of each complete sine wave of the AC supply in order to convert it into a DC supply. Then this type of circuit is called a -half-wave|| rectifier because it passes only half of the incoming AC power supply as shown below. During each -positivell half cycle of the AC sine wave, the diode is *forward biased* as the anode is positive with respect to the cathode resulting in current flowing through the diode. During each -negativell half cycle of the AC sinusoidal input waveform, the diode is *reverse biased* as the anode is negative with respect to the cathode.

Full Wave Rectifier Circuit

Like the half wave circuit, a full wave rectifier circuit produces an output voltage or current which is purely DC or has some specified DC component. Full wave rectifiers have some fundamental advantages over their half wave rectifier counterparts. The average (DC) output voltage is higher than for half wave, the output of the full wave rectifier has much less ripple than that of the half wave rectifier producing a smoother output waveform. In a **Full Wave Rectifier** circuit two diodes are now used, one for each half of the cycle. A multiple winding transformer is used whose secondary winding is split equally into two halves with a common centre tapped connection.

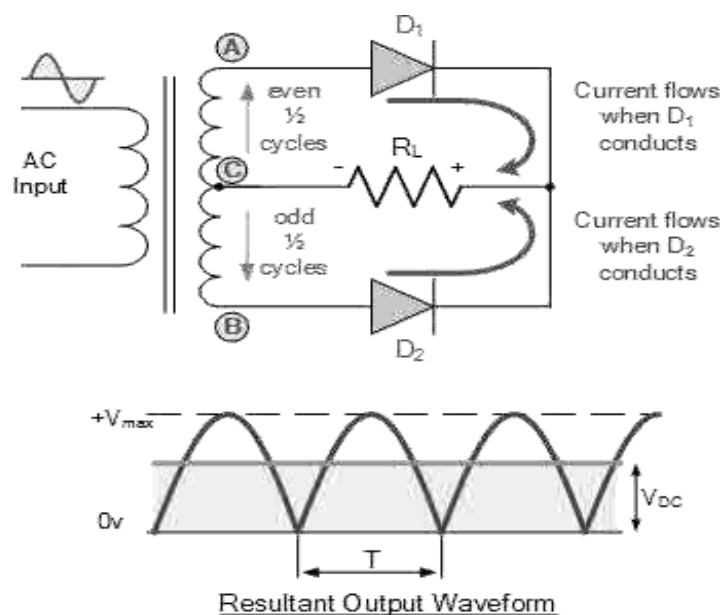

This configuration results in each diode conducting in turn when its anode

terminal is positive with respect to the transformer centre point C producing an output during both half-cycles, twice that for the half wave rectifier so it is 100% efficient as shown below. The full wave rectifier circuit consists of two *power diodes* connected to a single load resistance (R_L) with each diode taking it in turn to supply current to the load. When point A of the transformer is positive with respect to point C, diode D_1 conducts in the forward direction as indicated by the arrows. When point B is positive (in the negative half of the cycle) with respect to point C, diode D_2 conducts in the forward direction and the current flowing through resistor R is in the same direction for both half-cycles. As the output voltage across the resistor R is the phasor sum of the two waveforms combined, this type of full wave rectifier circuit is also known as a -bi-phase circuit.

Three phase Half Wave Rectifier

A three phase half wave rectifier, as the name implies, consists of a three phase transformer. Given below is a star connected secondary three phase transformer with three diodes connected to the three phases as shown in the figure. The neutral point 'Ntrl' of this secondary is considered as the earth for the circuit and is given as the negative terminal for the load.

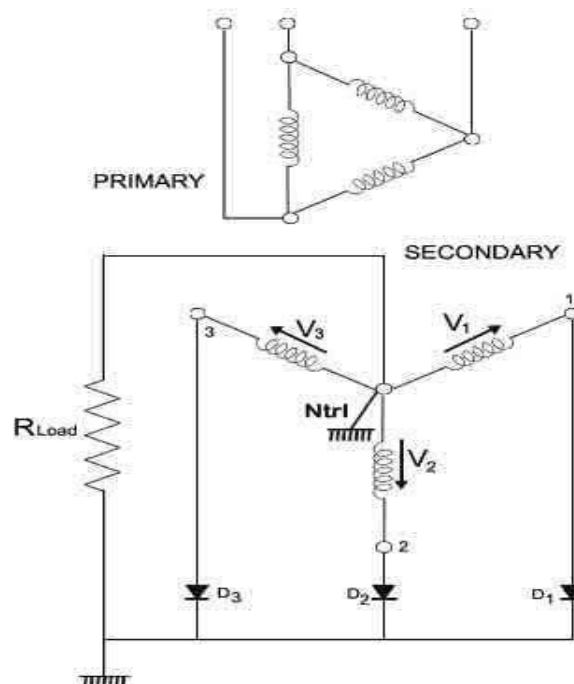

The input and the output wave forms for the circuit above is shown below. For

each one- third of the cycle, each diode conducts. At the instant when one diode out of three is conducting, the other two are left inactive, at that instant their cathodes becomes positive with respect to the anodes. This process repeats for each of the three diodes.

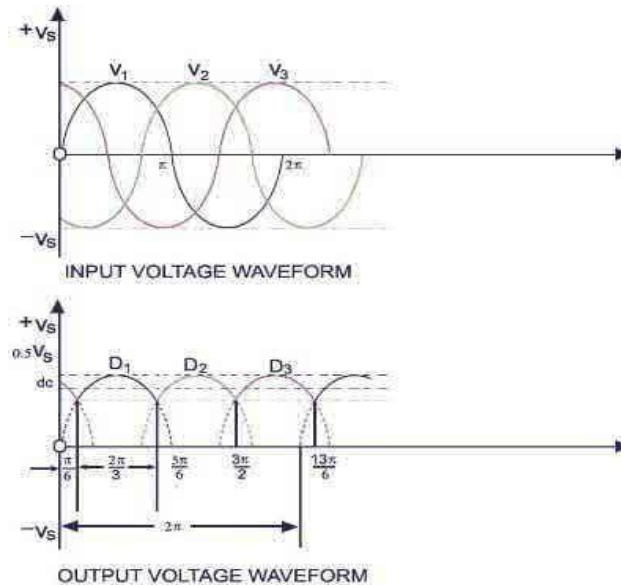

Three Phase Full Wave Rectifier

A three phase full wave rectifier can also be called a six wave half wave rectifier as shown in the figure. The diodes D_1 to D_6 will conduct only for $1/6^{\text{th}}$ of the period, with a period of $\pi/3$. As shown in the output wave form, the fluctuation of dc voltage is less in a three phase circuit. The variation lies between the maximum alternation voltage and 86.6% of this, with the average value being 0.955 times the maximum value.

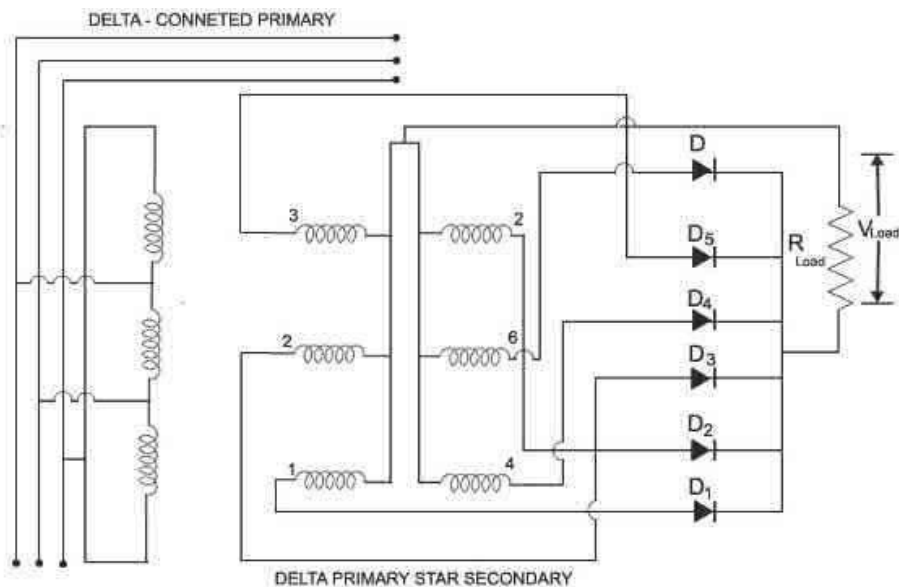

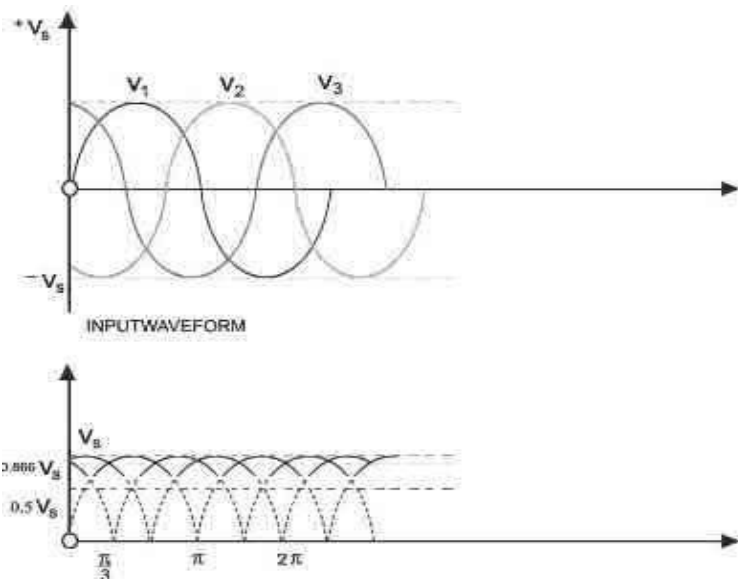

EE3014 POWER ELECTRONICS FOR RENEWABLE ENERGY SYSTEMS**UNIT IV-POWER CONVERTERS FOR WIND SYSTEMS****4.3-PWM INVERTERS****THREE PHASE PULSE WIDTH MODULATED (PWM) INVERTER**

Pulse width modulated (PWM) inverters are among the most used power-electronic circuits in practical applications. These inverters are capable of producing ac voltages of variable magnitude as well as variable frequency. The PWM inverters are very commonly used in adjustable speed ac motor drive loads where one needs to feed the motor with variable voltage, variable frequency supply. For wide variation in drive speed, the frequency of the applied ac voltage needs to be varied over a wide range. The applied voltage also needs to vary almost linearly with the frequency. PWM inverters can be of single phase as well as three phase types.

There are several different PWM techniques, differing in their methods of implementation. However in all these techniques the aim is to generate an output voltage, which after some filtering, would result in a good quality sinusoidal voltage waveform of desired fundamental frequency and magnitude. Nature of Pole Voltage Waveforms Output by PWM

Inverters Unlike in square wave inverters the switches of PWM inverters are turned on and off at significantly higher frequencies than the fundamental frequency of the output voltage waveform.

The time instances at which the voltage polarities reverse have been referred here as notch angles. It may be noted that the instantaneous magnitude of pole voltage waveform remains fixed at half the input dc voltage (E_{dc}). When upper switch (SU), connected to the positive dc bus is on, the pole voltage is $+ 0.5 E_{dc}$ and when the lower switch, connected to the negative dc bus, is on the instantaneous pole voltage is $- 0.5 E_{dc}$.

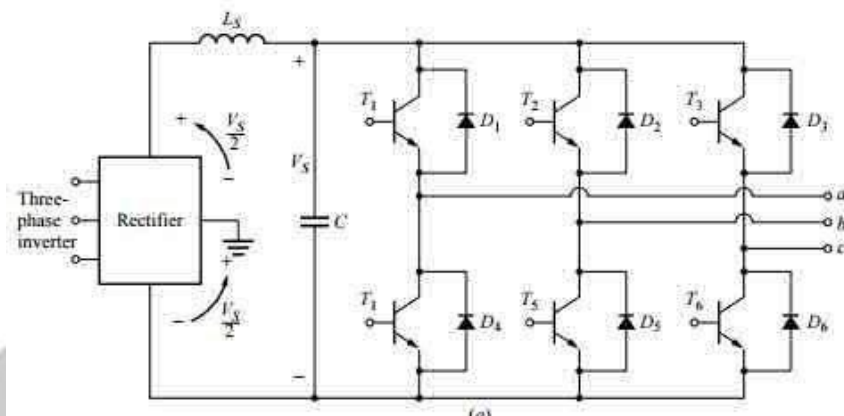

3 phase VSI using power transistors

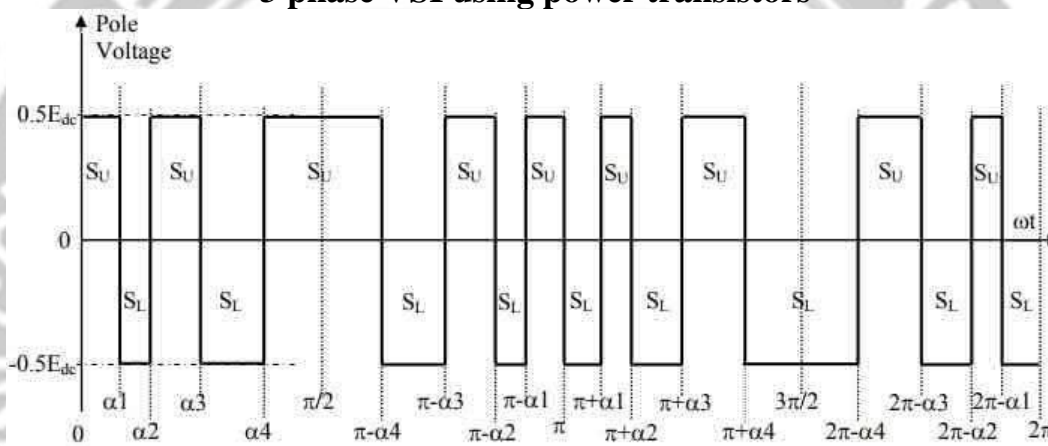

A typical pole-voltage waveform of a PWM inverter

The switching transition time has been neglected in accordance with the assumption of ideal switches. It is to be remembered that in voltage source inverters, meant to feed an inductive type load, the upper and lower switches of the inverter pole conduct in a complementary manner. That is, when upper switch is on the lower is off and vice-versa. Both upper and lower switches should not remain on simultaneously as this will cause short circuit across the dc bus. On the other hand one of these two switches in each pole (leg) must always conduct to provide continuity of current through inductive loads. A sudden disruption in inductive load current will cause a large voltage spike that may damage the inverter circuit and the load.



EE3014 POWER ELECTRONICS FOR RENEWABLE ENERGY SYSTEMS

UNIT IV-POWER CONVERTERS FOR WIND SYSTEMS

4.4 - GRID-INTERACTIVE INVERTERS - MATRIX CONVERTER

GRID INTERACTIVE (GRID-TIE) INVERTERS

Introduction

A grid-tie inverter converts direct current (DC) into an alternating current (AC) suitable for injecting into an electrical power grid, normally 120V RMS at 60Hz or 240V RMS at 50 Hz. Grid-tie inverters are used between local electrical power generators: solar panel, wind turbine, hydro-electric, and the grid. In order to inject electrical power efficiently and safely into the grid, grid-tie inverters must accurately match the voltage and phase of the grid sine wave AC waveform. Some electricity companies will pay for electrical power that is injected into the grid. Payment is arranged in several ways. With net metering the electricity company pays for the net power injected into the grid, as recorded by a meter in the customer's premises. For example, a customer may consume 400 kilowatt-hours over a month and may return 500 kilowatt-hours to the grid in the same month. In this case the electricity company would pay for the 100 kilowatt hours balance of power fed back into the grid. Feed-in tariff, based on a contract with a distribution company or other power authority, is where the customer is paid for electrical power injected into the grid.

Operation

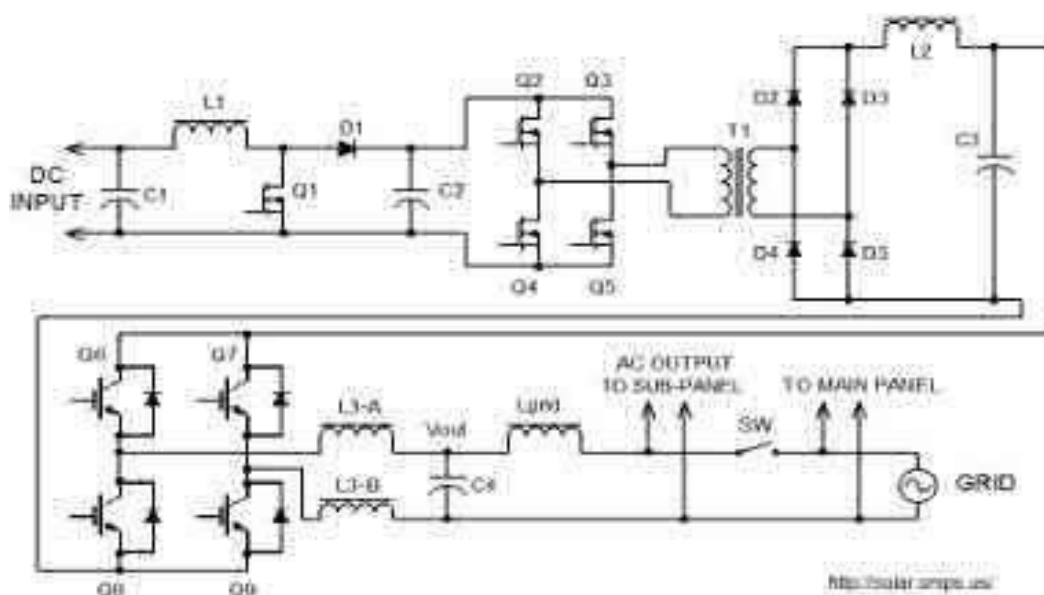

Grid-tie inverters convert DC electrical power into AC power suitable for injecting into the electric utility company grid. The grid tie inverter (GTI) must match the phase of the grid and maintain the output voltage slightly higher than the grid voltage at any instant. A high-quality modern grid-tie inverter has a fixed unity power factor, which means its output voltage and current are perfectly lined up, and its phase angle is within 1 degree of the AC power grid. The inverter has an on-board computer which senses the current AC grid waveform, and outputs a voltage to correspond with the grid. However, supplying reactive power to the grid might be necessary to keep the voltage in the local grid inside allowed limitations. Otherwise, in a grid segment with considerable power from renewable sources, voltage levels might rise too much at times of high production, i.e. around noon with solar panels.

Grid-tie inverters are also designed to quickly disconnect from the grid if the utility grid goes down. It ensures that in the event of a blackout, the grid tie inverter will shut down to prevent the energy it transfers from harming any line workers who are sent to fix the power grid.

Properly configured, a grid tie inverter enables a home owner to use an alternative power generation system like solar or wind power without extensive rewiring and without batteries. If the alternative power being produced is insufficient, the deficit will be sourced from the electricity grid.

Types

Grid-tie inverters include conventional low-frequency types with transformer coupling, newer high-frequency types, also with transformer coupling, and transformer-less types. Instead of converting direct current directly into AC suitable for the grid, high-frequency transformers types use a computer process to convert the power to a high-frequency and then back to DC and then to the final AC output voltage suitable for the grid. Transformer-less inverters are lighter, smaller, and more efficient than inverters with transformers. But transformer-less inverters have been slow to enter the market because of concerns that transformer-less inverters, which do not have galvanic isolation between the DC side and grid, could inject dangerous DC voltages and currents into the grid under fault conditions.

MATRIX CONVERTERS

Introduction

The main advantage of matrix converter is elimination of dc link filter. Zero switching loss devices can transfer input power to output power without any power loss. But practically it does not exist. The switching frequency of the device decides the THD of the converter. Maximum power transfer to the load is decided by nature of the control algorithm. Matrix converter has a maximum input output voltage transfer ratio limited to 87 % for sinusoidal input and output waveforms, which can be improved. Further, matrix converter requires more semiconductor devices than a conventional AC-AC indirect power frequency converter. Since monolithic bi-directional switches are available they are used for switching purpose. Matrix converter is particularly sensitive to the disturbances of the input voltage to the system. The instantaneous power flow does not have to equal power output. The difference between the input and output power must be absorbed or delivered by an energy storage element within the converter. The matrix converter replaces the multiple conversion stages and the intermediate energy storage element by a single power conversion stage, and uses a matrix of semiconductor bidirectional switches connecting input and output terminals. With this general arrangement of switches, the power flow through the converter can reverse. Because of the absence of any energy storage element, the instantaneous power input must be equal to the power output, assuming idealized zero-loss switches.

Single Phase Matrix Converter

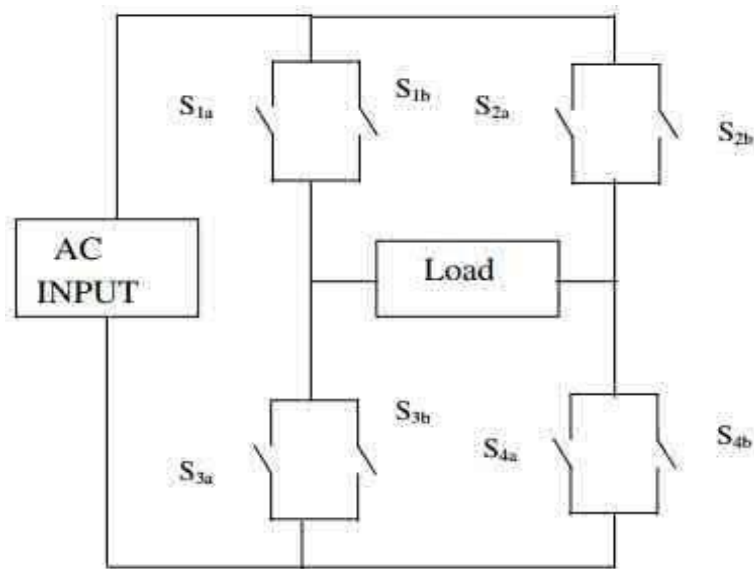

Single Phase Matrix Converter

The AC/AC converter is commonly classified as an indirect converter which utilizes a dc link between the two ac systems and converter that provides direct conversion. This converter consists of two converter stages and energy storage element, which convert input ac to dc and then reconvert dc back to output ac with variable amplitude and frequency. The operation of this converter stages is decoupled on an instantaneous basis by the energy storage elements and controlled independently, so long as the average energy flow is equal. Figure shows the single phase matrix converter switching arrangement.

Three Phase Matrix Converter

Three phase matrix converter consists of nine bidirectional switches. It has been arranged into three groups of three switches. Each group is connected to each phase of the output. These arrangements of switches can connect any input phase. These 3x3 arrangements can have 512 switching states. Among them only 27 switching states are permitted to operate this converter. Here A, B and C are input phase voltage connected to the output phase. Figure shows synchronous operating state vectors of three matrix converter. It shows that the converter switches are switched on rotational basis. In this case no two switches in a leg are switched on simultaneously. These states will not generate gate pulse when one phase of the supply is switched off.

Circuit scheme of a three phase to three phase matrix converter

The matrix converter consists of 9 bi-directional switches that allow any output phase to be connected to any input phase. The input terminals of the converter are connected to a three phase voltage-fed system, usually the grid, while the output terminal are connected to a three phase current-fed system, like an induction motor might be. The capacitive filter on the voltage-fed side and the inductive filter on the current-fed side represented in the scheme are intrinsically necessary. Their size is inversely proportional to the matrix converter switching frequency. It is worth noting that due to its inherent bi-directionality and symmetry a dual connection might be also feasible for the matrix converter: a current-fed system at the input and a voltage-fed system at the output. Taking into account that the converter is supplied by a voltage source and usually feeds an inductive load, the input phases should never be short-circuited and the output currents should not be interrupted. From a practical point of view these rules imply that one and only one bi-directional switch per output phase must be switched on at any instant. By this constraint, in a three phase to three phase matrix converter 27 are the permitted switching combinations.

EE3014 POWER ELECTRONICS FOR RENEWABLE ENERGY SYSTEMS**UNIT V - HYBRID RENEWABLE ENERGY SYSTEMS****5.1 - NEED FOR HYBRID SYSTEMS****HYBRID RENEWABLE ENERGY SYSTEMS****Introduction**

The renewable energy technologies include power generation from renewable energy sources, such as wind, PV(photovoltaic), MH (micro hydro), biomass, ocean wave, geothermal and tides. In general, the key reason for the deployment of the above energy systems are their benefits, such as supply security, reduced carbon emission, and improved power quality, reliability and employment opportunity to the local people. Since the RE resources are intermittent in nature therefore, hybrid combinations of two or more power generation technologies, along with storage can improve system performance. Hybrid Renewable Energy System (HRES) combines two or more renewable energy resources with some conventional source (diesel or petrol generator) along with storage, in order to fulfill the demand of an area.

Methodology

It is essential to have a well-defined and standardized frame work/steps taken for hybrid system based power generation for rural electrification. These steps are as follows:

Demand Assessment:

Using accurate load forecasting of remote villages, the load demand can be fetched.

During load survey, following factors may be considered:

- Demand for street lighting
- Number of houses, schools, health centers, commercial establishment and their energy requirement
- Number of small scale industries and their energy demand
- Miscellaneous demand

Resource Assessment:

Resource assessment can be done by calculating potential available in wind, MHP, solar, Biomass, Biogas, and other renewable energy resources using meteorological data available.



Demand is fulfilled by Hybrid renewable energy system.

This can be done by combining one or more renewable energy sources with conventional energy sources. Some Hybrid renewable system configurations are as follows:

- PV/Wind/diesel generator HRES
- PV/wind/fuel cell HRES
- Wind/battery HRES
- Biomass/wind/diesel generator HRES
- PV/Wind/Biomass/fuel cell HRES

Need for Hybrid Systems

As conventional fossil fuel energy sources diminish and the world's environmental concern about acid deposition and global warming increases, renewable energy sources (solar, wind, tidal, biomass and geothermal etc) are attracting more attention as alternative energy sources. These are all pollution free and one can say eco friendly. These are available at free of cost in India, there is severe power shortage and associated power quality problems. The quality of the grid supply in some places is characterized by large voltage and frequency fluctuations, scheduled and un-scheduled power cuts and load restrictions. Load shedding in many cities in India due to power shortage and faults is a major problem for which there is no immediate remedy in the near future since the gap between the power demand and supply is increasing every year.

In India wind and solar energy sources are available all over the year at free of cost whereas tidal and wave are coastal area. Geothermal is available at specific location. To meet the demand and for the sake of continuity of power supply, storing of energy is necessary. The term hybrid power system is used to describe any power system combine two or more energy conversion devices, or two or more fuels for the same device, that when integrated, overcome limitations inherent in either. Usually one of the energy sources is a conventional one (which necessarily does not depend on renewable energy resource) powered by a diesel engine, while the other(s) would be renewable viz. solar photovoltaic, wind or hydro. The design and structure of a hybrid energy

system obviously take into account the types of renewable energy sources available locally, and the consumption the system supports. For example, the hybrid energy system presented here is a small-scale system and the consumption of power takes place during nights.

The wind energy component will make a more significant contribution in the hybrid system than solar energy. Although the energy produced by wind during night can be used directly without storage. Battery is needed to store solar and wind energy produced during the



day. In addition to the technical considerations, cost benefit is a factor that has to be incorporated into the process of optimizing a hybrid energy system. In general, the use of wind energy is cheaper than that of solar energy. In areas where there is a limited wind source, a wind system has to be over-dimensioned in order to produce the required power, and these results in higher plant costs. It has been demonstrated that hybrid energy systems (renewable coupled with conventional energy source) can significantly reduce the total life cycle cost of a standalone power supplies in many off-grid situations. Numerous hybrid systems have been installed across the world, and expanding renewable energy industry has now developed reliable and cost competitive systems using a variety of technologies.

Benefits of Hybrid Systems

Improved reliability a robust power supply and downtime minimization during power outages could be achieved by virtue of varying the power sources, which is vital indeed due to its ability to provide backup power. System failure or disruption of diesel supply to the community are factors leading to utilizing an alternate generating system encompassing renewable energy / diesel hybrid system as to encourage continuous and reliability power supply. Photovoltaic and wind energy system attributive to fewer moving parts, requiring less maintenance than diesel, thus reduces downtime during repairs or routine maintenance. In fact, renewable energy sources being original and free, is more securing than diesel thus, beneficial to facilities.

The ability of renewable energy working in tandem with diesel, contributes to high quality and dynamic electricity services for 24 hours / day even as in a conventional system, the hours / day. The cost of photovoltaic or wind power generation lies in the form of upfront capital expenditures whereby the operation and maintenance expenses are low. Therefore, the generating cost via photovoltaic or wind is marginally more than a conventional system with respect to the additional generating capacity, nevertheless promises customer satisfaction of a continuous electricity supply. Reduced emissions and noise pollution Diesel generation emits air / water pollution agents as well as loud noise, proving the essentiality of renewable energy or diesel retrofits application in power generation which adopts an

environmental-friendly technology. In fact, renewable energy system is also substantially quieter than diesel generators. Continuous power by incorporating diesel generator with renewable energy system, diesel generator is able to boost up the electricity supply during sudden increase in energy demand or when the batteries capacity decreases and thus, facilities face no supply interruption.

Reduced cost Renewable energy or diesel hybrid system act as the most cost-effective way of generating electricity with regards to savings on fuel consumption and lower

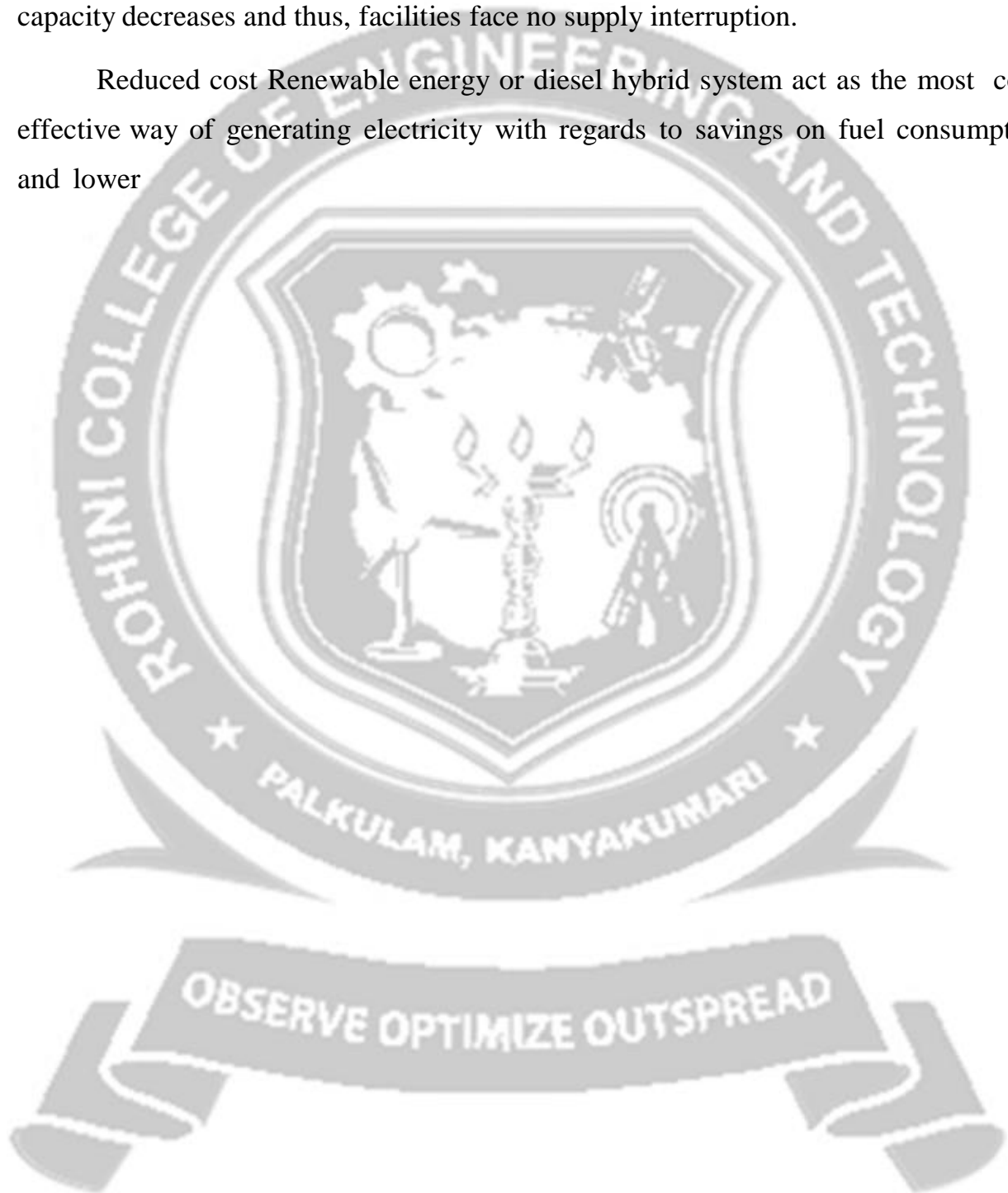

maintenance cost. For a conventional diesel system at remote area, the fuel and transportation cost is typically very high, as well as the service and spare parts cost which grossly excessive to rural community. Efficient use of energy Hybrid system promotes efficient use of power since renewable energy system could be configured to cope with base load whilst the peak load could be met via diesel generator



EE3014 POWER ELECTRONICS FOR RENEWABLE ENERGY SYSTEMS**UNIT V - HYBRID RENEWABLE ENERGY SYSTEMS****5.2- RANGE AND TYPE OF HYBRID SYSTEMS****RANGE AND TYPE OF HYBRID SYSTEMS****Hybrid System Characteristics**

Although hybrid energy systems are open, they can have the characteristics of a closed system if a subsystem with the function of monitoring is introduced as a feedback between output (consumer) and input (controller). As inputs of particular hybrid system cannot be changed. However, the load may be changed. With a backup system as another energy source the system can be designed as a partial closed-loop feedback system. There are various possibilities to make combination of different energy sources. Selection of energy source for hybrid system is mainly depends upon availability at the place where it going to be stabilized. In general in India solar energy is available almost all the places and infrastructure for power generation is rugged. Hence need low maintenance so it is smart to choose to have PV one of the energy sources in hybrid system. Wave and tidal energy available only at sea shore and need large capital investment and more maintenance, therefore not compatible for household hybrid system. But can be use in large power hybrid system. Corrosion because of seawater is a major drawback. Wind energy source is also a good choice but more preferable for open land hybrid system and status of wind throughout the year is also important. India has monsoon climate hence has enough potential of wind energy. Biomass energy is good option but it needs regular feeding to continuously operate. Biomass with grid hybrid system is broadly used in sugar mill in India. In residential applications, biomass can be used for space heating or for cooking. Businesses and industry use biomass for several purposes including space heating, hot water heating, and electricity generation.

Wind/PV Hybrid System

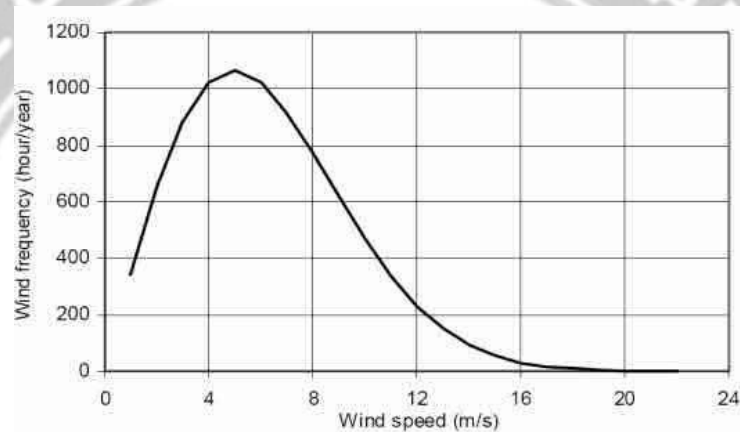
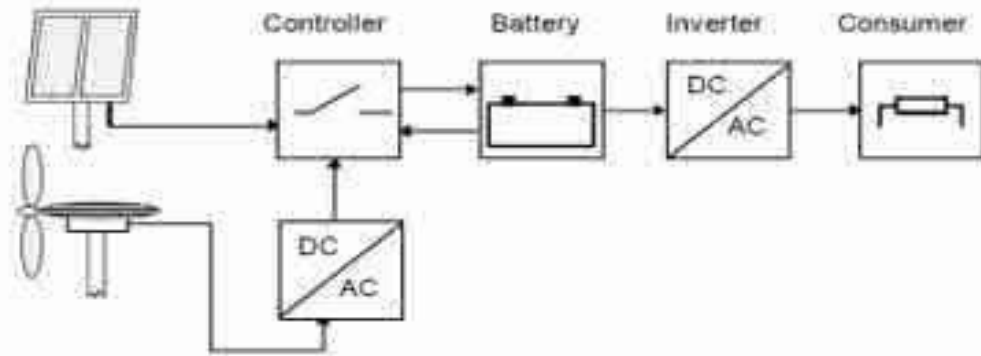

A typical hybrid energy system consists of solar and wind energy sources. The principle of an open loop hybrid system of this type is shown in Figure. The power produced by the wind generators is an AC voltage but have variable amplitude and frequency that can then be transformed into DC to charge the battery. The controller protects the battery from overcharging or deep discharging. As high voltages can be used to reduce system losses, an inverter is normally introduced to transform the low DC voltage to an AC voltage of 230V of frequency 50 Hz. The hybrid PV-wind generator system has been designed to supply continuous power of 1.5 kW and should have the following capabilities: Maximizes the electric power produced by the PV panels or by the wind generator by detecting and tracking the point of maximum power stores the electric energy in lead-acid batteries for a stable repeater operation. Control of the charge and discharge processes of the batteries protects wind generator from over speeding by connecting a dummy load to its output.

PV/Hydro Hybrid System

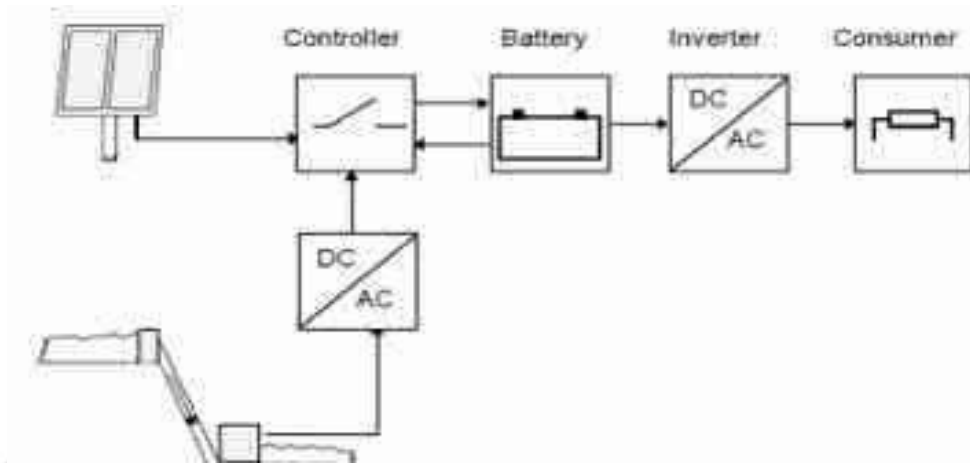

The block diagram of hybrid system, which combines PV with hydro system, is shown above. In this system there is a small reservoir to store the water. This type of hybrid system sometimes depends upon the geographical condition where the water at some height is available. System capacity is depends upon at the water quantity and solar radiation. The power supplied by falling water is the rate at which it delivers energy, and this depends on the flow rate and water head. The local water flow and head are limited at this project site, and a relatively simple hydro energy component is used in the project. Hydropower available is may be of runoff river type hence produces variable amplitude and frequency voltage. It can be use to charge the battery after converting it into DC.

Biomass-PV-Diesel Hybrid System

Biomass is matter usually thought of as garbage. Some of it is just substance lying around -- dead trees, tree branches, yard clippings, leftover crops, wood chips and bark and sawdust from lumber mills. It can even include used tires and livestock manure. The waste wood, tree branches and other scraps are gathered together in big trucks. The trucks bring the waste from factories and from farms to a biomass power plant. Here the biomass is dumped into huge hoppers. This is then fed into a furnace where it is burned. The heat is used to boil water in the boiler, and the energy in the steam is used to turn turbines and generators. Other application of Biomass is that it can also be tapped right at the landfill with burning waster products. When garbage decomposes, it gives off methane gas. Pipelines are put into the landfills and the methane gas can be collected. It is then used in power plants to make electricity.

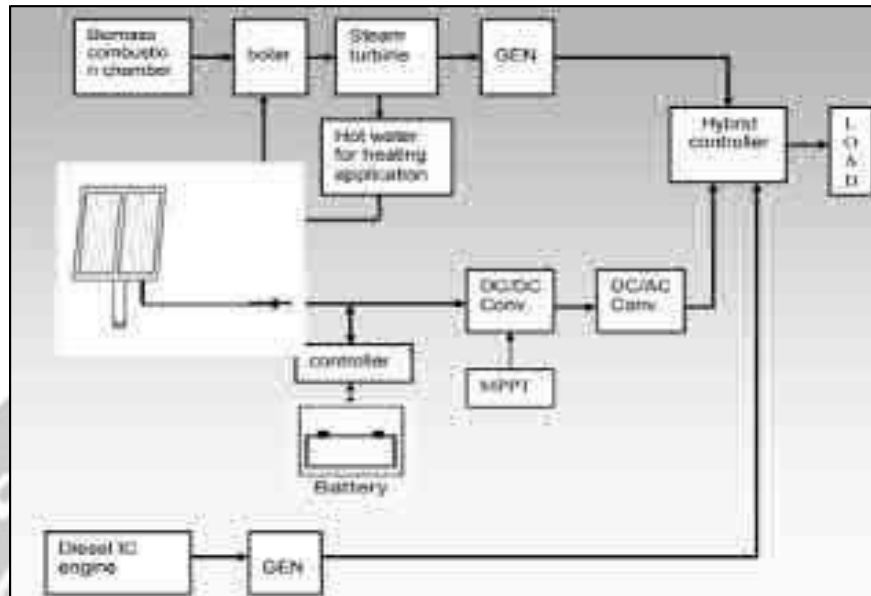

In hybrid system diesel energy is only work as a backup source. When the demand on its peak, the available sources are insufficient for that then the diesel back is required. There is a controller, which maintains the energy balance during the load variation. It assigns the priority among the energy sources. It also maintains the synchronizing the voltage signal coming from the different sources. Suppose the instantaneous magnitude of voltage signal coming from PV sources is differ from that of coming from other source say biomass. Hence it causes the local circulating power flow.

Hybrid PV diesel system

A photovoltaic diesel hybrid system ordinarily consists of a PV system, diesel gensets and intelligent management to ensure that the amount of solar energy fed into the system exactly matches the demand at that time. Basically the PV system complements the diesel gensets. It can supply additional energy when loads are high or relieve the genset to minimize its fuel consumption.

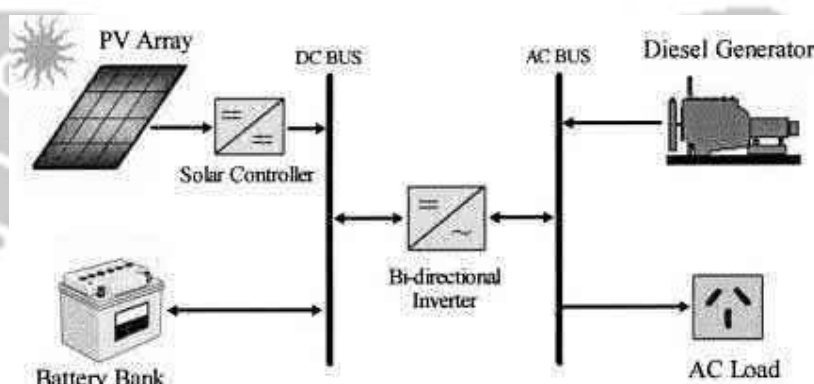

In the future, excess energy could optionally be stored in batteries, making it possible for the hybrid system to use more solar power even at night. Intelligent management of various system components ensures optimal fuel economy and minimizes CO₂ emissions.

Advantages of a photovoltaic diesel hybrid system

In contrast to power supply systems using diesel gensets, and despite their higher initial cost, PV systems can be amortized in as little as four to five years, depending on the site and system size, and they have low operating costs. In addition, PV systems are flexible and can be expanded on a modular basis as the energy demand grows. Compared to pure gensets systems, a photovoltaic diesel hybrid system provides numerous advantages:

- Lower fuel costs
- Reduced risk of fuel price increases and supply shortages
- Minimal CO₂ .

Components of photovoltaic diesel hybrid system

PV inverters

PV inverters are the central components of the fuel Save Solution. Designed specifically to be used in weak utility grids, they are suitable for high voltage and frequency fluctuations. They also remain extremely productive in harsh ambient conditions such as heat, moisture, salty air, among others. A centralized PV system contains only one string into a central point where direct current is converted to alternating current. In a decentralized PV system, the PV power is divided into many strings, which are converted into alternating current by several inverters.

PV array

The solar power is generated in the PV modules, which can be mounted on the ground or on a roof, depending on local conditions. Inverters are compatible with all PV module types and technologies currently available on the market.

Fuel save Controller

The fuel save controller provides the perfect interface between the gensets, PV systems and loads, managing demand-based PV feed-in into the diesel-powered grid. As the central component of the fuel save solution, it ensures maximum security with reduced fuel costs and minimizes CO₂ emissions.

Diesel Genset

In grid-remote regions, pure diesel systems often provide the energy for industrial applications. They constitute the local grid, ensuring a constant power supply to all connected users. Because the gensets require a constant fuel supply, they are often the system's highest operating cost. In regions with weak utility grids, diesel gensets often serve as a backup during grid power outages.

Optional storage batteries

To boost the efficiency of the entire energy supply system, it is advisable to include a storage battery. When solar irradiation is insufficient or energy is needed after dark, the storage battery supplies the required energy, ensuring optimal hybrid system operation.

PV/SOLAR THERMAL/GRID-CONNECTED HYBRID SYSTEM

The hybrid system that combines wind, solar, and diesel power generation system has become popular because of its advantages over either single system. The main advantages of hybrid systems are fuel saving lower atmospheric contamination, savings in maintenance, silent systems, and connection to other power supplies which enable higher service quality than traditional single-source generation systems. The main components of hybrid systems are: the power sources, the storage devices, the power management center, and monitor and control devices. There are two main advantages of the system compared to others. First, the energy of the proposed system is used wisely and efficiently by monitoring the load power and the available renewable energy to define the quantity of needed power and to select the best available source. Secondly, additional batteries are used as a dumped load in the system, which can be used if there is a shortage in the renewable energy source to minimize the usage of the diesel engine. In addition, a wireless monitoring system will be used to help in self-troubleshooting and a fast alarm system, which will minimize maintenance efforts.

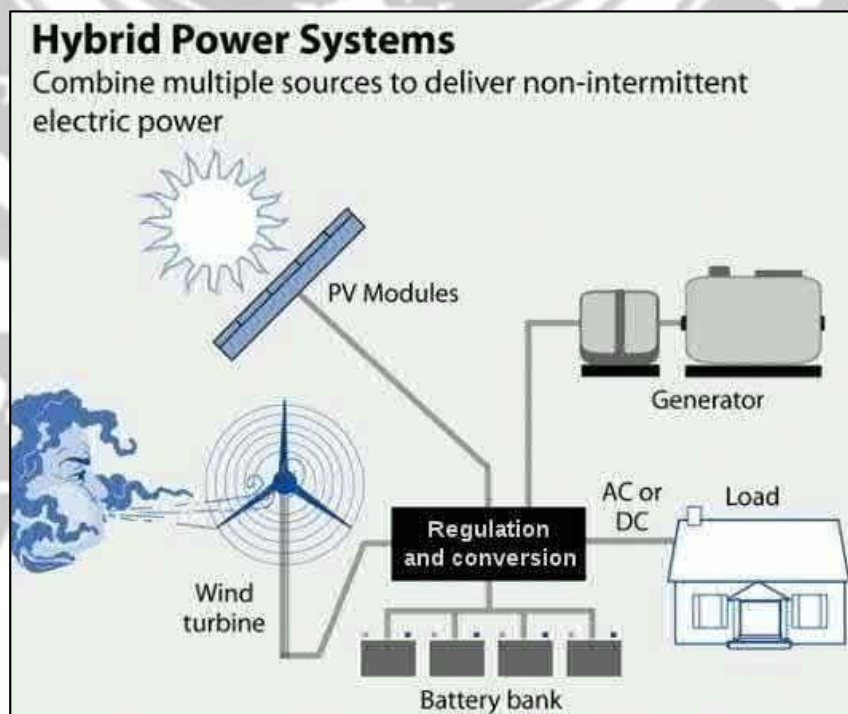

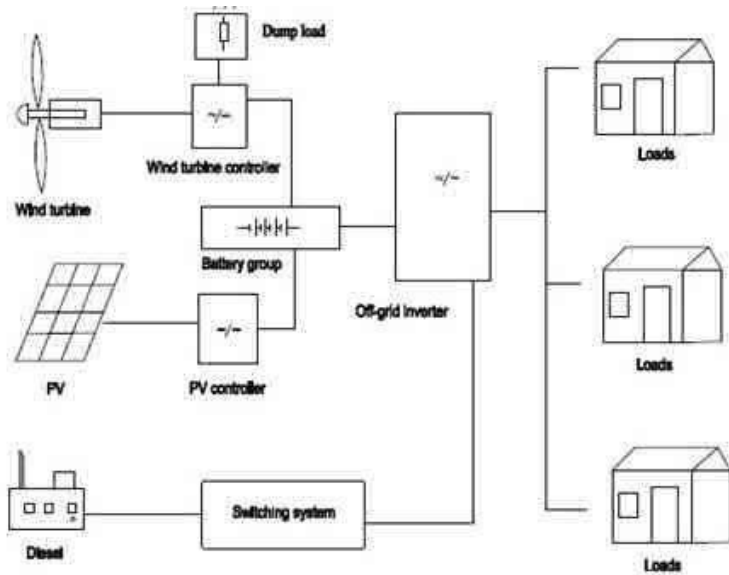

Hybrid Solar Wind Diesel Power Generation system has different schematics that each has its own advantages and implementation. In the scheme illustrated in Figure, the battery is charged directly from the photovoltaic (PV) module and the wind turbine where each has its own charge controller. The load receives its required power from all energy sources via an inverter to convert the DC to AC. The battery is charged in similar way to the first scheme but the only difference is that the load receives its required power via the battery not others. Also, there is no dump load in this case.

The charge controller receives the power from the energy sources (PV module and the wind turbine) and delivers the power to the battery if it is not fully charged, to the dump load if the battery is fully charged. If the battery is not fully charged and the output power from the renewable energy sources is not satisfactory, the diesel engine is turned on to supply the load with the needed power until the battery is fully charged again. The sensors are used for controlling the power flow among the system devices and elements, and troubleshooting purposes. For wind turbine, if the wind sensor reading does not match the proper amount of energy produced by wind turbine, the controller will send a command to the generator housed in the wind turbine to shut off. For the PV module, if the light intensity sensor reading does not match the amount of power produced by the PV module, the controller will send a command to disconnect the PV module from the charge controller. The system will take the power input from both the wind turbine and solar panel and send them to the charge controller. The charge controller will direct the power to the battery or the dump load battery based on battery voltage input.

When the battery voltage sensor inputs data that the battery is full, the charge controller will switch to dump load. However, when the battery is undercharged, the diesel engine will be switched on to supply the load with the power needed until the battery is charged again.

Moreover, the other sensors will be used for the troubleshooting purpose. For example, the system will be able to identify problem in the wind turbine or the solar panel. Such as when the wind speed and the light intensity sensors reading do not match with the input power given to the system that is read by the voltage and current sensors. Furthermore, the fuel level sensor will sense the diesel engine is running out of fuel.



EE3014 POWER ELECTRONICS FOR RENEWABLE ENERGY SYSTEMS

UNIT V - HYBRID RENEWABLE ENERGY SYSTEMS

5.3- Case studies of Wind

Case studies of Wind-PV system

Many remote communities around the world cannot be physically or economically connected to an electric power grid. The electricity demand in these areas is conventionally supplied by small isolated diesel generators. The operating costs associated with these diesel generators may be unacceptably high due to discounted fossil fuel costs together with difficulties in fuel delivery and maintenance of generators. In such situations, renewable energy sources, such as solar photovoltaic (PV) and wind turbine generator provide a realistic alternative to supplement engine-driven generators for electricity generation in off-grid areas. It has been demonstrated that hybrid energy systems can significantly reduce the total life cycle cost of standalone power supplies in many off-grid situations, while at the same time providing a reliable supply of electricity using a combination of energy sources. Numerous hybrid systems have been installed across the world, and the expanding renewable energy industry has now developed reliable and cost competitive systems using a variety of technologies. In a report, India's gross renewable energy potential (up to 2032) is estimated at 220 GW.

It is likewise noted in the report that, with a renewable energy capacity of 14.8 GW (i.e. 9.7% of the total installed generation capacities of 150 GW as on 30 June 2009), India has barely scratched the surface of a huge opportunity. However, in the last couple of years itself, the share of renewable energy in installed capacity has grown from 5 to 9.7%. This implies an enormous potential in energy generation, which can achieve several hundred GW with current renewable energy technologies. As the cost of building solar PV-wind capacity continues to fall over the next five to ten years; a significant scale-up of renewable generation is a very realistic possibility in the developing world. Thousands of villages across the globe are still being exiled from electricity and energizing these villages by extended grids or by diesel generators alone will be uneconomical. Moreover, with the current resource crunch with government, these villages receive low priority for grid extension because of lower economic return potential. Standalone solar PV-wind hybrid energy systems can provide economically viable and reliable electricity to such local needs.

Many countries with an average wind speed in the range of 5–10 m/s and average solar insolation level in the range of 3–6 KWh/m² are pursuing the option of wind and PV system to

minimize their dependence on fossil-based non-renewable fuels. Autonomous wind systems do not produce usable energy for a considerable portion of time during the year. This is primarily due to relatively high cut-in wind speeds which ranges from 3.5 to 4.5 m/s. In order to overcome this downtime, the utilization of solar PV and wind hybrid system is advised. Such systems are usually equipped with diesel generators to meet the peak load during the short periods when there is a deficit of available energy to cover the load demand. Diesel generator sets, while being relatively inexpensive to purchase, are generally expensive to operate and maintain, especially at low load levels. In general, the variation of solar and wind energy does not match the time distribution of the demand.

DESCRIPTION OF HYBRID RENEWABLE ENERGY SCHEMES

A hybrid renewable PV–wind energy system is a combination of solar PV, wind turbine, inverter, battery, and other addition components. A number of models are available for PV–wind combination as a PV hybrid system, wind hybrid system, and PV–wind hybrid system, which are employed to satisfy the load demand. Once the power resources (solar and wind flow energy) are sufficient excess generated power is fed to the battery until it is fully charged. Thus, the battery comes into play when the renewable energy sources (PV–wind) power is not able to satisfy the load demand until the storage is depleted. The operation of hybrid PV–wind system depends on the individual element. In order to evaluate the maximum output from each component, first the single component is modeled, thereafter which their combination can be evaluated to meet the require dependability. If the electric power production, though this type of individual element, is satisfactory the actual hybrid system will offer electrical power at the very least charge.

Hybrid photovoltaic system

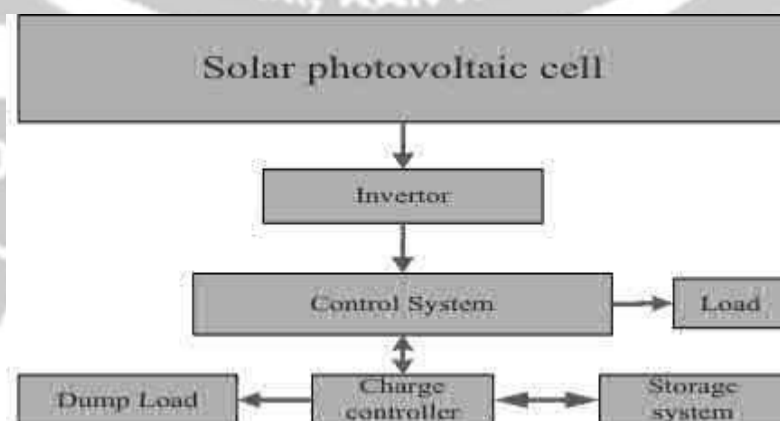

Solar energy is one of the site-dependent, non-polluting energy sources, and is available in great quantity. It is a potential source of alternative/renewable energy and utilization of solar radiation for power generation reduces the dependence on fossil fuel. Solar PV power generation

unit consists of PV generator, diesel generator, and inverter and battery system. For improved performance and better control, the role of battery storage is very important. The necessary condition for the design of the hybrid PV systems for maximum output power is hot climate. This type of system is cost effective and reliable, especially for those locations where the power supplies though the grid is not suitable and the cost of the transmission line is very high such as remote and isolated areas. Designed a system for computing production cost associated with hybrid PV battery method in which the size associated with PV method is calculated on such basis as electrical requirements not attained. For standalone hybrid PV system, analysis of reliability is determined in the term of loss of load (LOL) probability.

Hybrid wind energy system

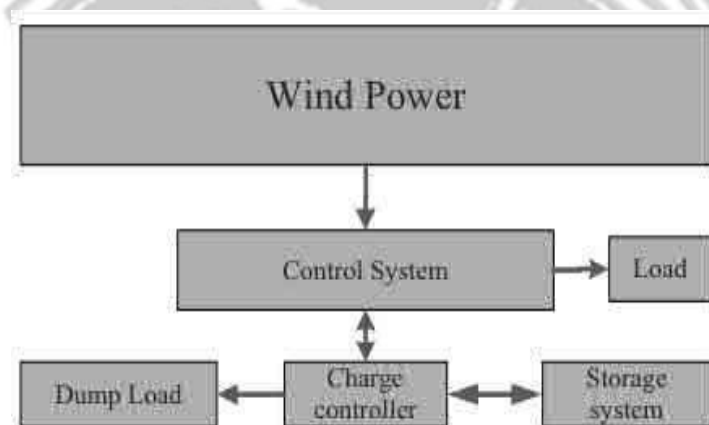

For the design of a reliable and economical hybrid wind system a location with a better wind energy potential must be chosen. Optimal sizing of a hybrid wind system and forecasting of a hybrid system based on several optimization techniques are obtained based on the application. A methodology is obtained for identifying the wind turbine generator parameters as capacity factor which relates to identically rated available wind turbine and capacity factor calculated on the basis of wind speed data at different hours of the day of many years. Hybrid wind system performance, reliability, and reduction in the cost of energy (COE) can be obtained by using a battery backup system. When the hybrid system generated power is in surplus, this power is used for loading the batteries for backup security and this charge battery power is used when the load requirement is not supplied by design hybrid system. Figure shows the architecture of wind hybrid energy system.

Hybrid photovoltaic/wind energy system

PV and wind system, both depending on weather condition, individual hybrid PV and hybrid wind system does not produce usable energy throughout the year. For better performance of the standalone individual PV combination or wind combination need battery backup unit and

diesel generator set results to increase the hybrid system cost.



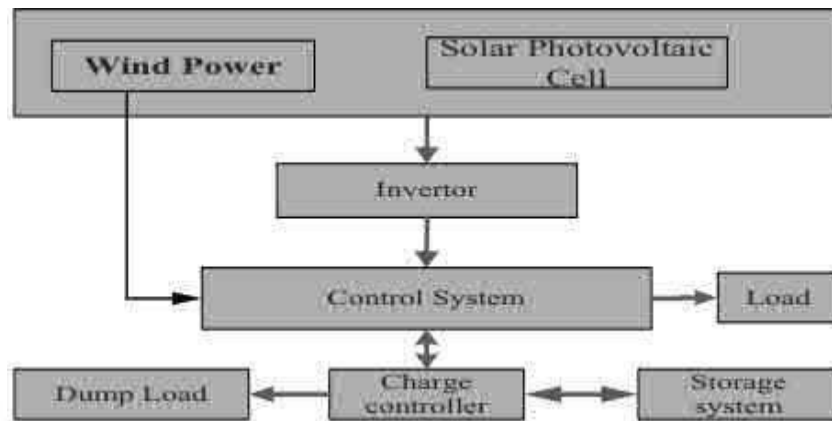

The main objective of the design is to obtain a cost-effective solution. Different artificial techniques are available for the optimal size of the hybrid system to minimize total annual cost. A couple of renewable energy sources—PV panels and wind turbines—are viewed as, together with traditional diesel generators in order to optimally design ability as well as functioning, preparing of the hybrid system. An optimization is used to match hourly supply and demand problem had been resolved to have sparse matrices and also the linear programming algorithm.

POWER ELECTRONICS TOPOLOGIES AND CONTROL FOR HYBRIDSOLAR PV-WIND SYSTEMS

Power electronics topologies and control for Grid-connected system

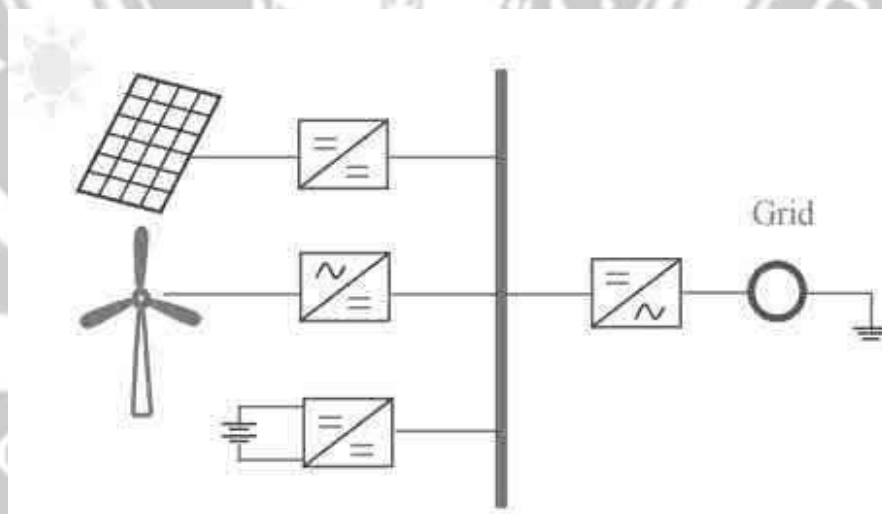

Figure 1: Grid-connected hybrid system at common DC bus

There are two topologies for grid-connected solar PV and wind hybrid system as can be seen from Figure 1 and 2. Figure 1 shows that the DC outputs' voltages from individual solar PV, wind and battery bank stream, through individual DC/DC and AC/DC units, are integrated on the DC side and go through one common DC/AC inverter which acts as an interface between the power sources and the grid to provide the desired power even with only one source available. Hence, the renewable energy sources act as current sources and can exchange power with the grid and the

common DC/AC inverter controls the DC bus voltage. The individual units can be employed for maximum power point tracking (MPPT) systems to have the maximum power from the solar PV and wind systems and the common DC/AC inverter will control the DC bus voltage. The battery bank is charged when there is an extra power and discharged (by supplying power) when there is shortage of power from the renewable energy sources.

Figure 2: Grid-connected hybrid system at common AC bus

On the other hand, Figure 2 shows that renewable energy sources are injecting power directly to the grid through individual DC/AC and AC/DC-DC/AC units. Many modules have proposed and presented experimental results of PV-wind-battery hybrid systems along with power management schemes and control systems. Such systems were capable to operate in different modes of operation and able to transfer from one mode to another easily. The voltage converters play an important role in controlling the amount and the type of voltage whether AC or DC and the duty cycle of those converters can be used to improve the quality of power. The response of the duty cycle of a DC/DC converter is relatively fast in MPPT control process. Numerous intelligent techniques are used for grid-connected hybrid PV/FC/battery power system to control flow of power via DC/DC and DC/AC converters.

Power electronics topologies and control for standalone system

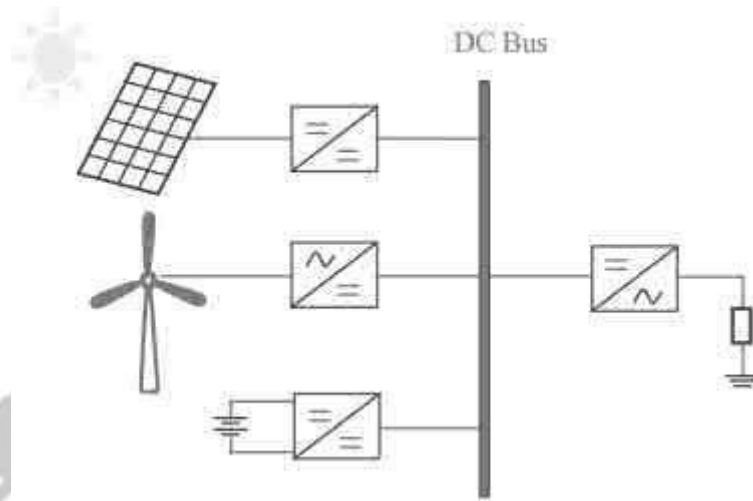

Figure 1: Stand-alone hybrid system at common DC bus

Figure 1 shows a stand-alone solar PV and wind hybrid system with DC common bus. One of its main advantages is to include DC interface bus for coupling different generation sources, which do not have to operate at a constant frequency and in synchronism. The DC bus line output voltage from all streams is set to be fixed and the output current from each source is controlled independently. The DC outputs' voltages from individual solar PV, wind and battery bank stream, through individual DC/DC and AC/DC units, are integrated on the DC side, combined in parallel and go through one common DC/AC inverter which acts as an interface between the power sources and the loads to provide the required power to the load by regulating the AC output voltage. The battery bank is interfaced by a DC/DC converter which regulates the DC-link bus voltage by charging (in case of extra power) or discharging the battery (in case of shortage of power). The renewable energy sources act as current sources and supply directly the loads. The interface common unit regulates the magnitude of the load's voltage. The individual AC/DC and DC/DC units can be employed for MPPT systems to have the maximum power from the solar PV and wind systems and the common DC/AC inverter will control magnitude of the load's voltage. The battery bank acts as a voltage source to control the common DC bus voltage by charging or discharging. In the conventional way for controlling the complete hybrid system, power electronics converters are used for maximum energy extract from solar and wind energy resources. In addition, advanced controlling techniques can remove the power fluctuations caused by the variability of the renewable energy sources.

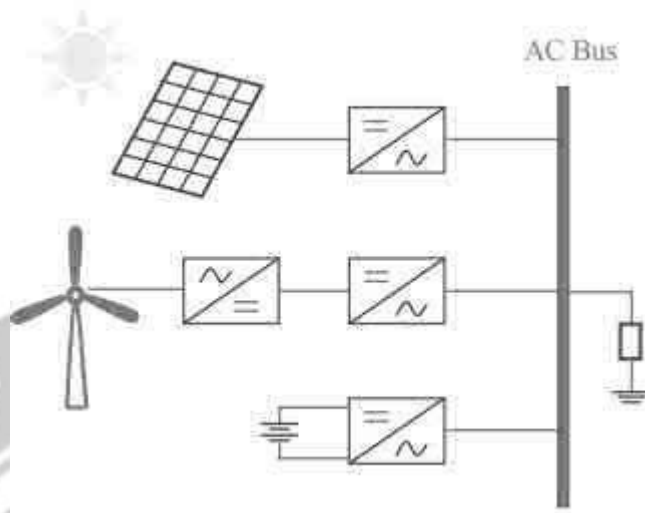

Figure 2: Stand-alone hybrid system at common AC bus

Figure 2 shows stand-alone solar PV and wind hybrid system with AC common bus. The form of pure AC bus bar system is widely used worldwide with lot of advantages, such as simple operation, plug and play scenario, low cost and easy extension according to the load's requirement. On the other hand, controlling AC voltage and frequency and energy management are some of the challenges for this type of topology. In this topology, the AC outputs' voltages from individual solar PV, wind and battery bank stream, through individual DC/AC and AC/DC-DC/AC units, are feeding the loads directly. The renewable energy sources can act as current sources provided that the battery bank exists as a voltage source to control the common AC bus voltage by charging or discharging. Hence, the individual units can be employed for MPPT systems to have the maximum power from the solar PV and wind systems provided that the battery bank exists as a voltage source to control the common AC bus voltage by charging or discharging. The battery bank is charged when there is an extra power and discharged and can supply power in case of shortage of power from the renewable energy sources. Droop control is normally applied to generators for frequency control and sometimes voltage control in order to have load sharing of parallel generators. It can also be used to perform proper current sharing in a micro-grid. With droop control, decentralized control for each interfacing converter is achieved. At the same time, no communication or only low bandwidth co-communication, such as power line communication, can be used in AC systems. Power flow was controlled using frequency and voltage drooping technique in order to ensure seamless transfer between grid connected and stand-alone parallel modes of operation.

EE3014 POWER ELECTRONICS FOR RENEWABLE ENERGY SYSTEMS

UNIT V - HYBRID RENEWABLE ENERGY SYSTEMS

5.4-PV MAXIMUM POWER POINT TRACKING (MPPT).

MAXIMUM POWER POINT TRACKING (MPPT)

Maximum Power Point Tracking

MPPT is a technique used commonly with wind turbines and photovoltaic (PV) solar systems to maximize power extraction under all conditions. Although solar power is mainly covered, the principle applies generally to sources with variable power: for example, optical power transmission and thermo-photovoltaic. PV solar systems exist in many different configurations with regard to their relationship to inverter systems, external grids, battery banks, or other electrical loads. Regardless of the ultimate destination of the solar power, though, the central problem addressed by MPPT is that the efficiency of power transfer from the solar cell depends on both the amount of sunlight falling on the solar panels and the electrical characteristics of the load. As the amount of sunlight varies, the load characteristic that gives the highest power transfer efficiency changes, so that the efficiency of the system is optimized when the load characteristic changes to keep the power transfer at highest efficiency. This load characteristic is called the **maximum power point** and **MPPT** is the process of finding this point and keeping the load characteristic there. Electrical circuits can be designed to present arbitrary loads to the photovoltaic cells and then convert the voltage, current, or frequency to suit other devices or systems, and MPPT solves the problem of choosing the best load to be presented to the cells in order to get the most usable power out.

Working of MPPT

Maximum Power Point Tracking (MPPT) is a technology approach used in solar PV inverters to optimize power output in less-than-ideal sunlight conditions. Most modern inverters are equipped with at least one MPPT input.

An MPPT tracker is analogous to a thumb placed over a garden hose. If you put your thumb over part of the opening of the hose (adding resistance to the circuit), the pressure (voltage) goes up and the stream flies faster, but less water (current) is getting through. If you completely cover the opening, nothing gets through. If you remove your thumb entirely, the maximum flow rate gets through, but the stream falls limply at your feet.

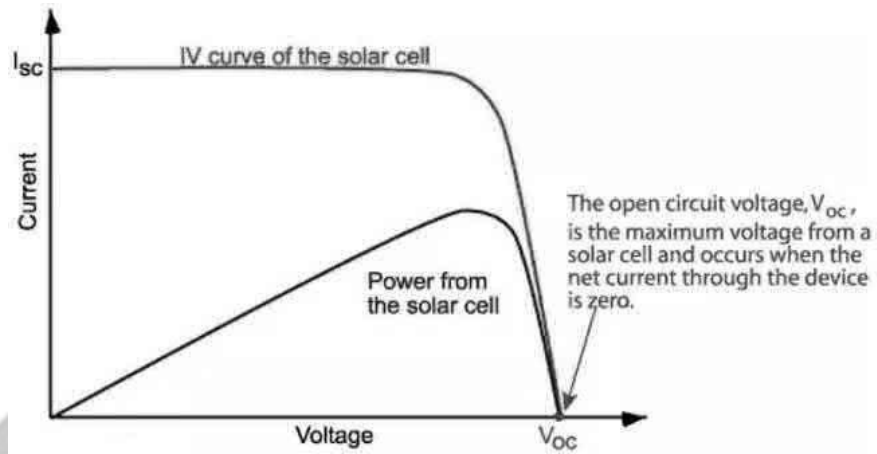

That is the basic mechanism of the MPPT tracker which varies resistance in the circuit to modify current and voltage. Now imagine that there are hundreds of pumps (solar panels) upstream of the hose and they are delivering water (energy) to you. Further complicating things, some of these pumps go offline at certain parts of the day (partial shading of the array). So the force behind the delivery of water will be constantly varying.

MAXIMUM POWER POINT TRACKING ALGORITHMS

MPPT algorithms are necessary in PV applications because the MPP of a solar panel varies with the irradiation and temperature, so the use of MPPT algorithms is required in order to obtain the maximum power from a solar array. Over the past decades many methods to find the MPP have been developed and published. These techniques differ in many aspects such as required sensors, complexity, cost, range of effectiveness, convergence speed, correct tracking when irradiation and/or temperature change, hardware needed for the implementation or popularity, among others. The different MPPT algorithms are discussed below.

Hill-climbing techniques

Algorithms are based on the -hill-climbing principle, which consists of moving the operation point of the PV array in the direction in which power increases. Hill-climbing techniques are the most popular MPPT methods due to their ease of implementation and good performance when the irradiation is constant. The advantages of these methods are the simplicity and low computational power they need.

Perturb and observe

The Perturb and observe (P&O) algorithm is also called -hill-climbing, but both names refer to the same algorithm depending on how it is implemented. Hill-climbing involves a perturbation on the duty cycle of the power converter and P&O a perturbation in the operating voltage of the DC link between the PV array and the power converter. In the case of the Hill-climbing, perturbing the duty cycle of the power converter implies modifying the voltage of the DC link between the PV array and the power converter, so both names refer to the same technique. In this method, the sign of the last perturbation and the sign of the last increment in the power are used to decide the next perturbation.

Incremental conductance

The incremental conductance algorithm is based on the fact that the slope of the curve power vs. voltage (current) of the PV module is zero at the MPP, positive (negative) on the left of it and negative (positive) on the right. It can be written as

$$\frac{\Delta V}{\Delta P} = 0 \left(\frac{\Delta I}{\Delta P} = 0 \right) \text{ at the MPP}$$

$$\frac{\Delta V}{\Delta P} > 0 \left(\frac{\Delta I}{\Delta P} < 0 \right) \text{ on the left}$$

$$\frac{\Delta V}{\Delta P} < 0 \left(\frac{\Delta I}{\Delta P} > 0 \right) \text{ on the right}$$

By comparing the increment of the power versus the increment of the voltage (current) between two consecutive samples, the change in the MPP voltage can be determined.

Fuzzy logic control

The use of fuzzy logic control has become popular over the last decade because it can deal with imprecise inputs, does not need an accurate mathematical model and can handle nonlinearity. The fuzzy logic consists of three stages: fuzzification, inference system and defuzzification. Fuzzification comprises the process of transforming numerical crisp inputs into linguistic variables based on the degree of membership to certain sets. The number of membership functions used depends on the accuracy of the controller, but it usually varies between 5 and 7. In some cases the membership functions are chosen less symmetric or even optimized for the application for better accuracy.

The rule base, also known as rule base lookup table or fuzzy rule algorithm, associates the fuzzy output to the fuzzy inputs based on the power converter used and on the knowledge of the user. The last stage of the fuzzy logic control is the defuzzification. In this stage the output is converted from a linguistic variable to a numerical crisp one again using membership functions. There are different methods to transform the linguistic variables into crisp values.. The advantages of these controllers, besides dealing with imprecise inputs, not needing an accurate mathematical model and handling nonlinearity, are fast convergence and minimal oscillations around the MPP.

Neural networks

Another MPPT method well adapted to microcontrollers is Neural Networks [8]. They came along with Fuzzy Logic and both are part of the so called -Soft Computing. The simplest example of a Neural Network (NN) has three layers called the input layer, hidden layer and output layer, as shown in Figure. More complicated NN's are built adding more hidden layers. The number of layers and the number of nodes in each layer as well as the function used in each layer vary and depend on the user knowledge. The input variables can be parameters of the PV array such as V_{oc} and I_{sc} , atmospheric data as irradiation and temperature or a combination of these. The output is usually one or more reference signals like the duty cycle or the DC-link reference voltage.

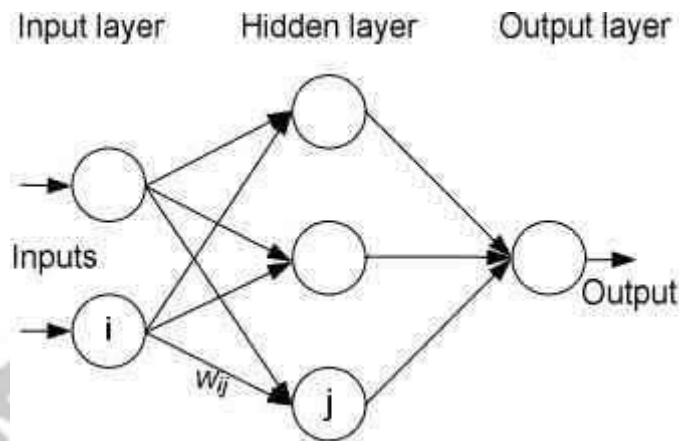

To execute this training process, data of the patterns between inputs and outputs of the neural network are recorded over a lengthy period of time, so that the MPP can be tracked accurately. The main disadvantage of this MPPT technique is the fact that the data needed for the training process has to be specifically acquired for every PV array and location, as the characteristics of the PV array vary depending on the model and the atmospheric conditions depend on the location.

Fractional open circuit voltage

This method uses the approximately linear relationship between the MPP voltage (V_{MPP}) and the open circuit voltage (V_{OC}), which varies with the irradiance and temperature.

$$V_{MPP} \approx K_1 V_{OC}$$

Where k_1 is a constant depending on the characteristics of the PV array and it has to be determined beforehand by determining the V_{MPP} and V_{OC} for different levels of irradiation and different temperatures. Once the constant of proportionality, k_1 , is known, the MPP voltage V_{MPP} can be determined periodically by measuring V_{OC} . To measure V_{OC} the power converter has to be shut down momentarily so in each measurement a loss of power occurs. Another problem of this method is that it is incapable of tracking the MPP under irradiation slopes, because the determination of V_{MPP} is not continuous. One more disadvantage is that the MPP reached is not the real one because the relationship is only an approximation.

Fractional short circuit current

Just like in the fractional open circuit voltage method, there is a relationship, under varying atmospheric conditions, between the short circuit current I_{SC} and the MPP current, I_{MPP} , as is shown by

$$I_{MPP} \approx K_2 I_{SC}$$

The coefficient of proportionality k_2 has to be determined according to each PV array, as

in the previous method happened with k_1 . Measuring the short circuit current while the system is



operating is a problem. It usually requires adding an additional switch to the power converter to periodically short the PV array and measure I_{sc} .

Current sweep

In this method the V-I characteristic curve is obtained using a sweep waveform for the PV array current. The sweep is repeated at fixed time intervals so the V-I curve is updated periodically and the MPP voltage (V_{MPP}) can be determined from it at these same intervals. On the other hand, the sweep takes certain time during which the operating point is not the MPP, which implies some loss of available power. Strictly speaking, it is not possible to track the MPP under irradiation slopes, because the MPP varies continuously. Only if the sweep is instantaneous the global MPP could be found, but that is impossible. Furthermore, the implementation complexity is high, the convergence speed is slow and both voltage and current measurements are required.

5.8. PARTICLE SWARM OPTIMIZATION BASED MPPT ALGORITHM FOR PV SYSTEM

This algorithm is used to reduce the steady state oscillation to practically zero once the maximum power point is located. Furthermore, it has ability to track the MPP for the extreme environmental conditions like large fluctuations of insolation and partial shading condition. The MPP tracker based on Particle Swarm Optimization for photovoltaic module arrays is capable of tracking global MPPs of multi-peak characteristic curves where the fixed values were adopted for weighing within the algorithm, the tracking performance lacked robustness, causing low success rates when tracking the global MPPs. Though the MPPs were tracked successfully, the dynamic response speed is low. The PSO based MPPT controller algorithm for various environmental conditions like fully shaded conditions and partially shaded conditions to find new global MPP with re-initialization of particles can be observed. The PSO has simple structure, easy implementation, and fast computation capability. It is able to locate the MPP for any type of P-V curve regardless of environmental variations and also to track the PV system as the search space of the PSO reduced and the time required for the convergence can be greatly reduced. The PSO based MPPT can be used to predict the I-V and P-V characteristics curves during partial shading condition also to evolve and ratify the photovoltaic system design encompassing the power converter and MPPT controller.

MAXIMUM POWER POINT TRACKING IN HYBRID PHOTO-VOLTAIC AND WIND ENERGY CONVERSION SYSTEM

Introduction

With exhausting of traditional energy resources and increasing concern of environment, renewable and clean energy is attracting more attention all over the world to overcome the increasing power demand. Out of all the renewable energy sources, Wind energy and solar energy are reliable energy sources. However, the renewable energy generation has a drawback that the change of the output characteristic becomes intense because the output greatly depends on climatic conditions, including solar irradiance, wind speed, temperature, and so forth. In this paper, combining the photovoltaic generation with wind power generation, the instability of an output characteristic each other was compensated. Photovoltaic generation and wind generation use Maximum Power Point Tracker (MPPT).

The Wind-solar complementary power supply system is a reasonable power supply which makes good use of wind and solar energy. This kind of power supply system can not only provide a bargain of low cost and high dependability for some inconvenient regions. In addition, the Wind/Solar complementary generation is more economical than a single PV or wind power generation in terms of both the cost and the protection of energy storage components. In stand-alone systems, sizing is extremely important since an adequate design lead to an efficient operation of the components with a minimum investment.

Modeling of Photo-Voltaic Hybrid Energy Conversion System

The construction of PV cell is very similar to that of the classical diode with a p-n junction formed by semiconductor material. When the junction absorbs light, the energy of absorbed photon is transferred to the electron-proton system of the material, creating charge carriers that are separated at the junction. The charge carriers in the junction region create a potential gradient, get accelerated under the electric field, and circulate as current through an external circuit. The solar cell is the basic building of the PV power system it produces about 1 W of power.

To obtain high power, numerous such cell are connected in series and parallel circuits on a panel (module), The solar array or panel is a group of a several modules electrically connected in series-parallel combination to generate the required current and voltage. The PV array must operate electrically at a certain voltage which corresponds to the maximum power point under the given operating conditions, i.e. temperature and irradiance. To do this, a maximum power point tracking (MPPT) technique should be applied. If the array is operating at voltage V and current I the operation point toward the maximum power point by periodically increasing or decreasing the

array voltage, is often used in many PV systems. The configuration of hybrid



wind and PV system is shown in Figure. This configuration is fit for stand-alone hybrid power system used in remote area. Wind and solar energy are converted into electricity and then sent to loads or stored in battery bank. The topology of hybrid energy system consisting of variable speed wind turbine coupled to a permanent magnet generator (PMG) and PV array. The two energy sources are connected in parallel to a common dc bus line through their individual dc-dc converters. The load may be dc connected to the dc bus line or may include a PWM voltage source inverter to convert the dc power into ac at 50 or 60 Hz. Each source has its individual control.

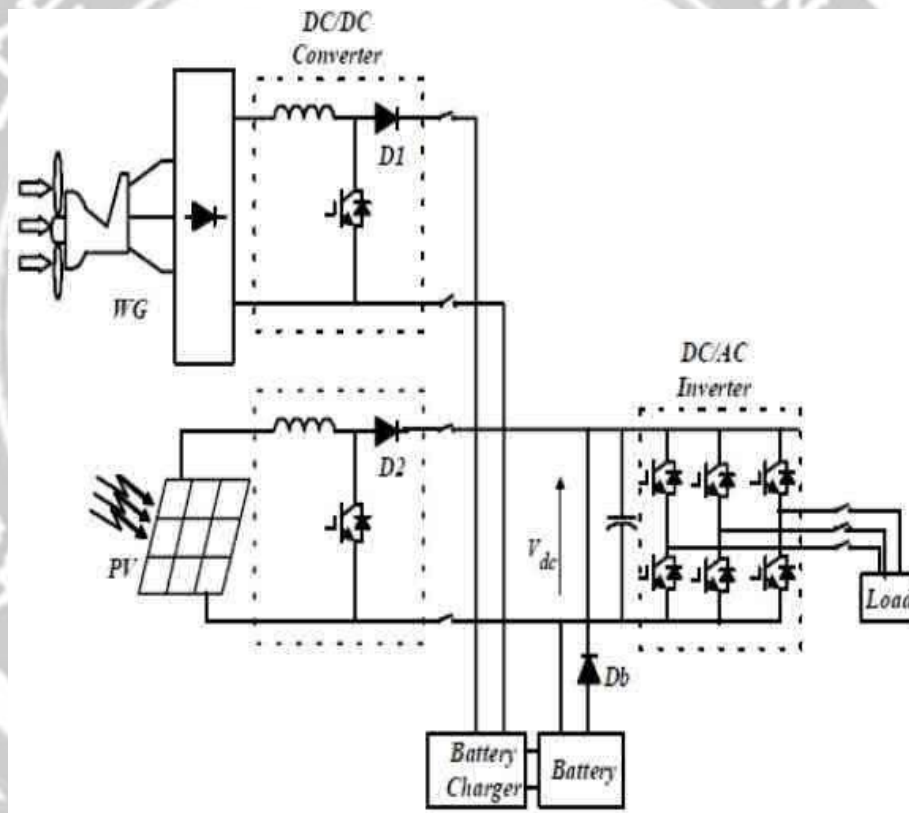

The output of the hybrid generating system goes to the dc bus line to feed the isolating dc load or to the inverter, which converts the dc into ac. A battery charger is used to keep the battery fully charged at a constant dc bus line voltage. When the output of the system is not available, the battery powers the dc load or discharged to the inverter to power ac loads, through a discharge diode. A battery discharge diode is to prevent the battery from being charged when the charger is opened after a full charge.

Biomass-Diesel Hybrid System

Combustion is a common process in biomass conversion technology. Application of combustion process is for solid fuels either from cultivated biomass or waste biomass. Biomass is widely available in hills and remote forest areas but becomes scarce during snowy winter. When its supply

stops and stock dwindles, energy route of biomass to electrical energy by incineration suffers a setback. This system needs a backup by diesel power electric generator to meet the known lighting and plug loads of residences, commercial establishments, hospitals and other life sustaining loads. Essential components of this hybrid configuration are:

- (a) 25 kW biomass generator.
- (b) Battery bank of 1000 Ah capacity
- (c) 15 kVA diesel generator.

A biomass-fired steam power plant is made hybrid with a diesel generator along with a controller, battery bank and load is shown in Figure 4.

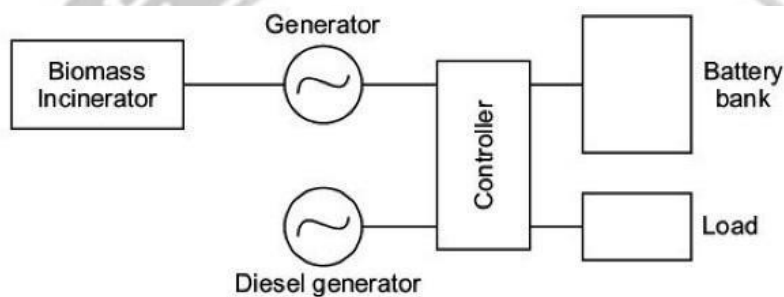

Figure 4 Biomass-diesel hybrid system.

To operate this system, economic viability is necessary by utilizing biomass generator to the full capacity and minimum use of diesel generator, for essential and lifesaving load during crisis period of biomass availability.

Micro Hydrel-PV Hybrid System

Micro hydel (up to 100 kW) power stations are low head (less than 3 m) installations and provide decentralized power in mountain regions, also in plains on canal falls. In remote areas of J & K, boarder districts of Arunachal Pradesh micro hydro power plants are the only source of energy. With the help of micro hydro power, rural electrification can be achieved besides providing power for pumped irrigation and grinding mills. In Arunachal Pradesh, 425 villages are being electrified by completing 46 small/ micro hydro power projects. However, there are 1058 villages which cannot be illuminated by micro hydel projects as at several locations, head is very low, while at other, quantity of water is small. Solution is to provide micro hydel-PV hybrid system as sunshine is available practically at all locations. Portable micro hydel sets of 15 kW capacities are installed with solar PV panels to complement each other as given in Figure 6.

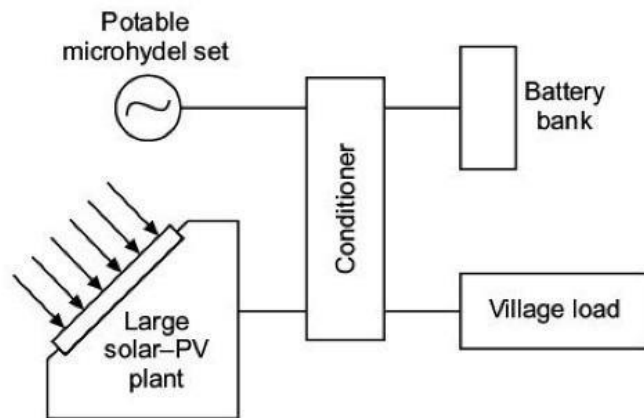

Figure 6 Micro hydel-PV hybrid system.

Micro hydel systems are provided with small dam store water to be used during night when solar PV panels stops power supply. A battery bank may be provided for emergency power supply. A battery bank may be provided for emergency power supply wherever required. Load management is carried out to maintain continuity of supply for 24 hours matching with the capacity of generating equipment.

