

Reg. No. :

E	N	G	G	T	R	E	E	.	C	O	M
---	---	---	---	---	---	---	---	---	---	---	---

Question Paper Code : 50539

B.E./B.Tech. DEGREE EXAMINATIONS, APRIL/MAY 2024.

For More Visit our Website
EnggTree.com

Third/Fourth Semester

Mechanical Engineering

CE 3491 – STRENGTH OF MATERIALS

(Common to : Industrial Engineering/Industrial Engineering and Management/
Mechanical Engineering (Sandwich)/Safety and Fire Engineering)

(Regulations 2021)

Time : Three hours

Maximum : 100 marks

Answer ALL questions.

PART A — (10 × 2 = 20 marks)

1. State Hooke's Law.
2. What is meant by Poisson's ratio?
3. Give the relationship between shear force and bending moment.
4. What is the application of perpendicular axis theorem?
5. Draw the shear force diagram for a cantilever beam of span 2 m carrying a point load of 5 kN at mid span.
6. Define stiffness of a spring.
7. State the Maxwell's reciprocal theorem.
8. Write down the boundary conditions of a cantilever beam for solving the integration constants to be used in Double Integration Method.
9. Distinguish between thin and thick cylinders.
10. What are the possible failure of a thin cylinder due to internal fluid pressure?

PART B — (5 × 13 = 65 marks)

11. (a) A copper rod of 40 mm diameter is surrounded tightly by a cast iron tube of 80 mm external diameter, the ends being firmly fastened together. When put to a compressive load of 30 kN, what load will be shared by each? Also determine the amount by which the compound bar shortens if it is 2 m long. Take : $E_{CI} = 175 \text{ GN/m}^2$ and $E_C = 75 \text{ GN/m}^2$.

Or

- (b) Two circular bar A and B of the same material are subjected to the same pull force (P) and are deformed by the same amount. What is the ratio of their length, if one of them has a constant diameter of 60 mm and the other uniformly tapers from 80 mm at one end to 40 mm at the other?
12. (a) A timber beam of rectangular section is to support a load of 24 kN uniformly distributed over a span of 4 m when beam is simply supported. If the depth of section is to be twice as breadth, and the stress in the timber is not to exceed 10 N/mm^2 , find the dimensions of the cross section.

Or

- (b) A 5 m simply supported beam is having a T-shaped cross section with the following dimensions: flange width 125 mm, flange thickness 25 mm, depth of web 175 mm and thickness of the web 25 mm. The beam carries a uniformly distributed load of intensity 2.5 kN/m over the entire span. Sketch the shear stress distribution.
13. (a) A hollow circular shaft is to have an inside diameter one half the outside diameter. It is to be designed to transmit 50 kW at a speed of 450 rpm and shear stress is not to exceed 85 N/mm^2 . Calculate
- (i) External diameter of the hollow shaft, (4)
 - (ii) The angle of relative twist in degrees between two sections 1.5 m apart, and (4)
 - (iii) Percentage difference in the weight of the hollow circular shaft as compared with a solid shaft designed for the same condition. Consider $G = 8.4 \times 10^4 \text{ N/mm}^2$. (5)

Or

- (b) A solid shaft transmits 250 kW at 100 rpm. If the shear stress is not to exceed 75 MPa, what should be the diameter of the shaft? If this shaft is to be replaced by a hollow one, whose diameter ratio is 0.6, determine the size and percentage of saving in weight, the maximum shear stress being the same.

14. (a) A simply supported beam of 8 m length carries two point loads of 64 kN and 48 kN at 1 m and 4 m respectively from the left hand end. Find the deflection under each load and the maximum deflection using Macaulay's method. $E = 210 \text{ GPa}$ and $I = 180 \times 10^6 \text{ mm}^4$.

Or

- (b) A simply supported beam AB of span 4 m carries a point load of 100 kN at its centre C. The value of moment of inertia for the left half is $1 \times 10^8 \text{ mm}^4$ and for the right half is $2 \times 10^8 \text{ mm}^4$. Find the slopes at the two supports and deflection under the load using conjugate beam method. Take Young's modulus as 200 GN/m^2 .
15. (a) A thin cylindrical shell 1 m in diameter, 3 m length and a wall thickness of 10 mm is subjected to an internal pressure of 1.5 MN/m^2 . Calculate the stresses, strain, change in dimensions. Hence change in volume. Assume the modulus of elasticity and Poisson's ratio of the shell material as 200 GN/m^2 and 0.3 respectively.

Or

- (b) A cylindrical vessel of 800 mm internal diameter with hemispherical ends is 1500 mm long on its cylindrical portion. If wall thickness on its hemispherical portion is 8 mm determine the minimum thickness required at the cylindrical portion. Also determine the total change in internal volume given that the internal pressure is 3 MPa, $E = 2 \times 10^5 \text{ N/mm}^2$ and Poisson's ratio = 0.25

PART C — (1 × 15 = 15 marks)

16. (a) State of stress at a point in a material is as shown in the Fig. 1. Determine
- Principal stresses, (3)
 - Maximum shear stress, (4)
 - Plane of maximum shear stress and (4)
 - The resultant stress on the plane of maximum shear stress. (4)

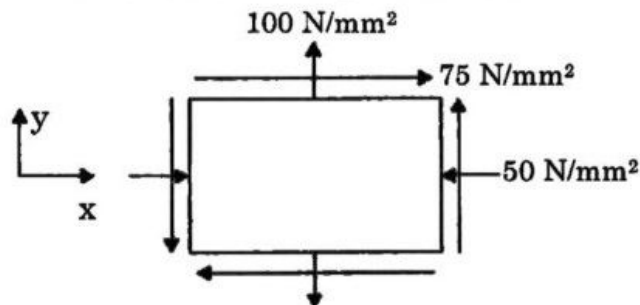

Fig. 1

Or

- (b) Draw the shear force and bending moment diagram for the overhanging beam as shown in the Fig. 2 and locate the points of contraflexure (s), if any.

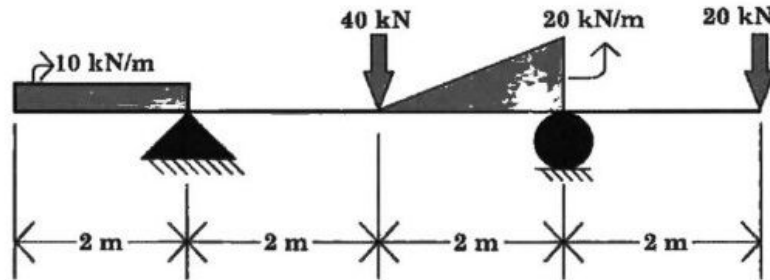

Fig. 2

